

# NLSX5004, NLSXN5004

## 4-Bit 100 Mb/s Configurable Dual-Supply Level Translator

The NLSX5004 and NLSXN5004 are 4-bit configurable dual-supply autosensing bidirectional level translators that do not require direction control pins. The A- and B-ports are designed to track two different power supply rails,  $V_{CCA}$  and  $V_{CCB}$  respectively. Both the  $V_{CCA}$  and the  $V_{CCB}$  supply rails are independently-configurable from 0.9 V to 3.6 V.

The NLSX5004 and NLSXN5004 have high dynamic output current capability, allowing the translators to drive high capacitive loads.

Enable input pins are available to reduce the power consumption. These pins may be used to disable both A- and B-ports by putting them in 3-state significantly reducing the supply current from both  $V_{CCA}$  and  $V_{CCB}$ . These pins are referenced to the  $V_{CCA}$  supply. The NLSX5004 has an active-High enable (EN) while the NLSXN5004 has active-Low enable ( $\overline{EN}$ ).

### Features

- Wide  $V_{CCA}$ ,  $V_{CCB}$  Operating Range: 0.9 V to 3.6 V
- $V_{CCA}$  and  $V_{CCB}$  are independent
  - $V_{CCA}$  may be greater than, equal to, or less than  $V_{CCB}$
- High 100 pF Capacitive Drive Capability
- High-Speed w/ 140 Mbps Guaranteed Data Rate for  $V_{CCA}$ ,  $V_{CCB} > 1.8$  V
- Low Bit-to-Bit skew
- Overvoltage Tolerant Enable and I/O Pins
- Non-preferential Power-Up Sequencing
- Partial Power-Off Protection
- Available packaging:
  - UQFN-12, SOIC14, TSSOP14, QFN-14, Other packages
- NLV Prefix for Automotive and Other Applications Requiring Unique Site and Control Change Requirements; AEC-Q100 Qualified and PPAP Capable
- These Devices are Pb-Free, Halogen Free/BFR Free and RoHS Compliant

### Typical Applications

- Mobile Phones, Infotainment Systems, Other Devices

### Important Information

- ESD Protection for All Pins:
  - HBM (Human Body Model) – 2000 V



ON Semiconductor®

[www.onsemi.com](http://www.onsemi.com)

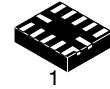

1  
**UQFN12**  
MU SUFFIX  
CASE 523AE

### MARKING DIAGRAMS

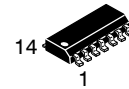
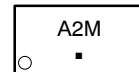

14  
1  
**SOIC14**  
D SUFFIX  
CASE 751A

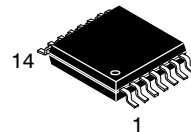
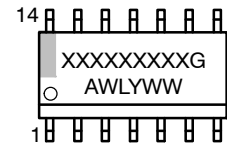

14  
1  
**TSSOP14**  
DT SUFFIX  
CASE 948G

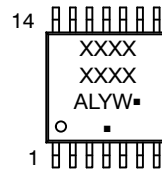

1  
**QFN14**  
MN SUFFIX  
CASE 485DE

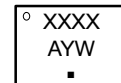

**QFN14**  
MN SUFFIX  
CASE 485AL

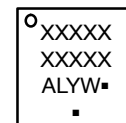

XXXXX = Specific Device Code  
M = Date Code  
A = Assembly Location  
L or WL = Wafer Lot  
Y = Year  
W or WW = Work Week  
G or ■ = Pb-Free Package

(Note: Microdot may be in either location)

### ORDERING INFORMATION

See detailed ordering and shipping information on page 11 of this data sheet.

# NLSX5004, NLSXN5004

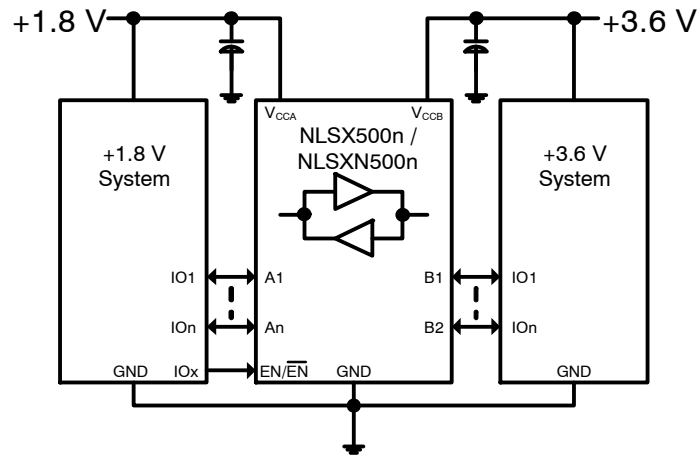

Figure 1. Typical Application Circuit

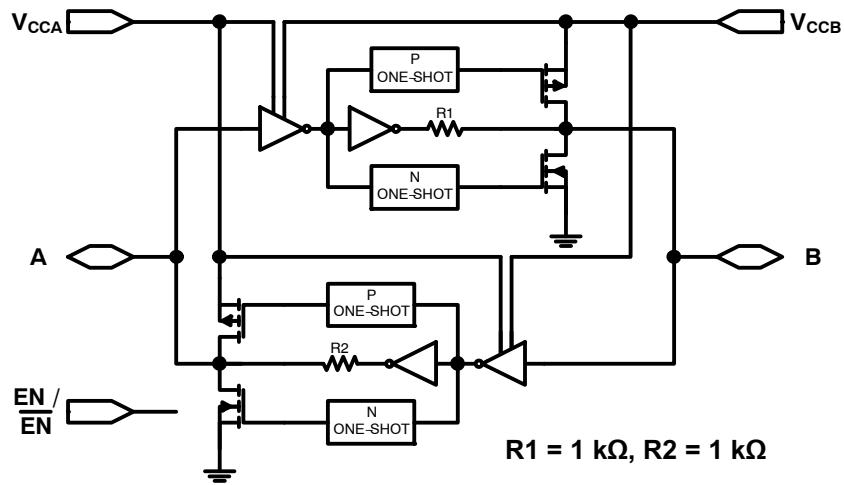

Figure 2. Functional Diagram (1 I/O Line)

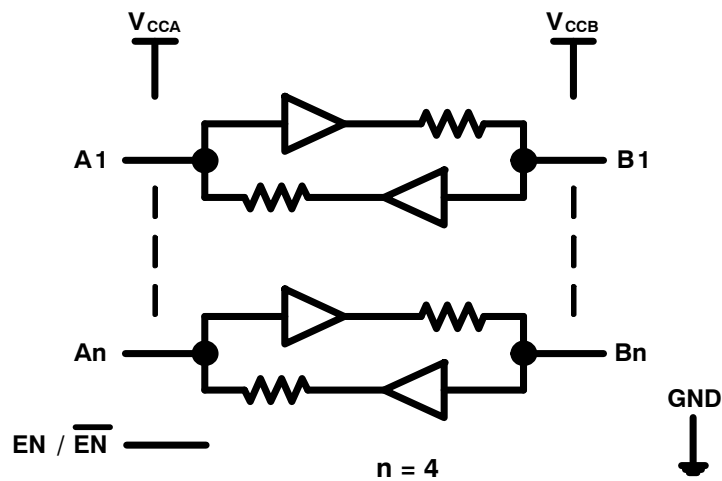

Figure 3. Logic Diagram

# NLSX5004, NLSXN5004

## PIN ASSIGNMENTS

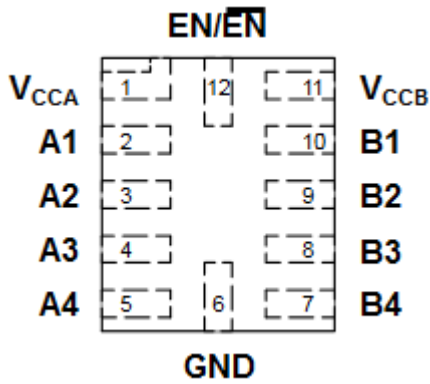

Figure 4. UQFN12

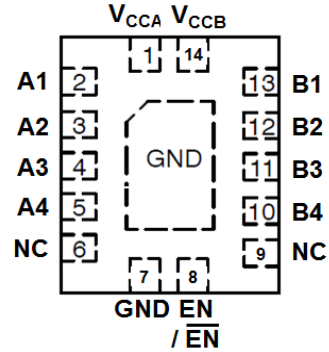

Figure 5. QFN14 (2.5 x 3.0)

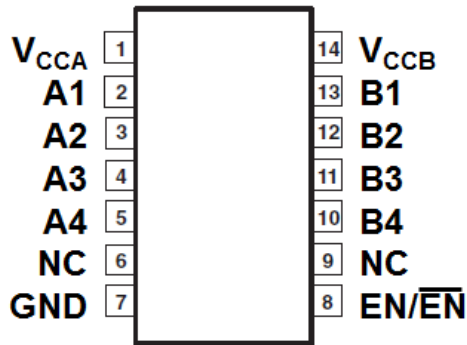

Figure 6. TSSOP / SOIC

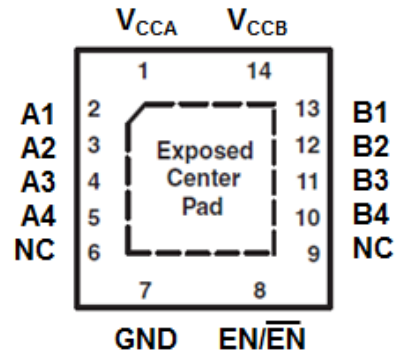

Figure 7. QFN14 (3.5 x 3.5)

### PIN DESCRIPTIONS

Pins	Description
V <sub>CCA</sub>	A-Port Supply Voltage
V <sub>CCB</sub>	B-Port Supply Voltage
GND	Ground
EN	Active-High Enable (NLSX500n), Referenced to V <sub>CCA</sub>
$\overline{\text{EN}}$	Active-Low Enable (NLSXN500n), Referenced to V <sub>CCA</sub>
A <sub>n</sub>	A-Port, Referenced to V <sub>CCA</sub>
B <sub>n</sub>	B-Port, Referenced to V <sub>CCB</sub>

### FUNCTION TABLE

NLSX500n	NLSXN500n	Operating Mode
EN	$\overline{\text{EN}}$	
L	H	An and Bn at Hi-Z
H	L	An and Bn Connected

# NLSX5004, NLSXN5004

**Table 1. MAXIMUM RATINGS**

Symbol	Parameter	Value	Condition	Unit
$V_{CCA}$	A-side DC Supply Voltage	-0.5 to +4.6		V
$V_{CCB}$	B-side DC Supply Voltage	-0.5 to +4.6		V
$V_{IN}$	Input/Output Voltage EN/ $\overline{EN}$	-0.5 to +4.6		V
	Power Down Mode ( $V_{CCA}$ and/or $V_{CCB} = 0$ V)	-0.5 to +4.6		
	Tri-State Mode ( $EN = L$ or $\overline{EN} = H$ )	-0.5 to +4.6		
	Active Mode			
	A-Port	-0.5 to $V_{CCA}+0.5$		
	B-Port	-0.5 to $V_{CCB}+0.5$		
$I_{IK}$	DC Input Diode Current	-50	$V_{IN} < GND$	mA
$I_{OK}$	DC Output Diode Current	-50	$V_O < GND$	mA
$I_{CCA}$	DC Supply Current Through $V_{CCA}$	$\pm 100$		mA
$I_{CCB}$	DC Supply Current Through $V_{CCB}$	$\pm 100$		mA
$I_{GND}$	DC Ground Current Through Ground Pin	$\pm 100$		mA
$T_{STG}$	Storage Temperature	-65 to +150		$^{\circ}C$

Stresses exceeding those listed in the Maximum Ratings table may damage the device. If any of these limits are exceeded, device functionality should not be assumed, damage may occur and reliability may be affected.

**Table 2. RECOMMENDED OPERATING CONDITIONS**

Symbol	Parameter	Min	Max	Unit
$V_{CCA}$	A-Port Supply Voltage	0.9	3.6	V
$V_{CCB}$	B-Port Supply Voltage	0.9	3.6	V
$V_I$	Input/Output Voltage EN/ $\overline{EN}$	GND	3.6	V
	Power Down Mode ( $V_{CCA}$ and/or $V_{CCB} = 0$ V)	GND	3.6	
	Tri-State Mode ( $EN = L$ or $\overline{EN} = H$ )	GND	3.6	
	Active Mode			
	A-Port	GND	$V_{CCA}$	
	B-Port	GND	$V_{CCB}$	
$T_A$	Operating Temperature Range	-40	+125	$^{\circ}C$
$\Delta t/\Delta V$	Input Transition Rise or Fall Rate $V_I$ from 30% to 70% of $V_{CCA}/V_{CCB}$	0	10	nS

Functional operation above the stresses listed in the Recommended Operating Ranges is not implied. Extended exposure to stresses beyond the Recommended Operating Ranges limits may affect device reliability.

# NLSX5004, NLSXN5004

**Table 3. DC ELECTRICAL CHARACTERISTICS**

Symbol	Parameter	Test Conditions (Note 1)	Pin/Port	V <sub>CCA</sub> (V)	V <sub>CCB</sub> (V)	-40°C to +85°C			-40°C to +125°C		Unit
						Min	Typ (Note 2)	Max	Min	Max	
V <sub>IH</sub>	Input HIGH Voltage		A, EN/ $\overline{\text{EN}}$	0.9–3.6	0.9–3.6	0.65 * V <sub>CCA</sub>	–	–	0.65 * V <sub>CCA</sub>	–	V
			B	0.9–3.6	0.9–3.6	0.65 * V <sub>CCB</sub>	–	–	0.65 * V <sub>CCB</sub>	–	V
V <sub>IL</sub>	Input LOW Voltage		A, EN/ $\overline{\text{EN}}$	0.9–3.6	0.9–3.6	–	–	0.35 * V <sub>CCA</sub>	–	0.35 * V <sub>CCA</sub>	V
			B	0.9–3.6	0.9–3.6	–	–	0.35 * V <sub>CCB</sub>	–	0.35 * V <sub>CCB</sub>	V
V <sub>OH</sub>	Output HIGH Voltage	I <sub>OH</sub> = –20 $\mu$ A	A	0.9–3.6	0.9–3.6	0.9 * V <sub>CCA</sub>	–	–	0.9 * V <sub>CCA</sub>	–	V
			B	0.9–3.6	0.9–3.6	0.9 * V <sub>CCB</sub>	–	–	0.9 * V <sub>CCB</sub>	–	V
V <sub>OL</sub>	Output LOW Voltage	I <sub>OL</sub> = 20 $\mu$ A	A	0.9–3.6	0.9–3.6	–	–	0.2	–	0.2	V
			B	0.9–3.6	0.9–3.6	–	–	0.2	–	0.2	V
I <sub>OZ</sub>	Tristate Output Leakage	(EN = 0V or $\overline{\text{EN}}$ = V <sub>CCA</sub> ); (A = 0 V or V <sub>CCA</sub> ) (B = 0 V or V <sub>CCB</sub> )									$\mu$ A
			A	0.9–3.6	0.9–3.6	–	0.01	$\pm$ 1.5	–	$\pm$ 4.5	
			B	0.9–3.6	0.9–3.6	–	0.01	$\pm$ 1	–	$\pm$ 3.5	
I <sub>CC</sub>	Supply Current	(EN = V <sub>CCA</sub> or $\overline{\text{EN}}$ = 0 V); I <sub>O</sub> = 0 A, (A = 0 V, B = 0 V) or (A = V <sub>CCA</sub> , B = V <sub>CCB</sub> )	V <sub>CCA</sub>	0.9–3.6	0.9–3.6	–	0.4	2.0	–	6.0	$\mu$ A
			V <sub>CCB</sub>	0.9–3.6	0.9–3.6	–	0.3	1.5	–	6.0	
I <sub>CCZ</sub>	Tristate Output Mode Supply Current	(EN = 0V or $\overline{\text{EN}}$ = V <sub>CCA</sub> ), (A = 0 V, B = 0 V) or (A = V <sub>CCA</sub> , B = V <sub>CCB</sub> )	V <sub>CCA</sub>	0.9–3.6	0.9–3.6	–	0.2	1.5	–	7.0	$\mu$ A
			V <sub>CCB</sub>	0.9–3.6	0.9–3.6	–	0.2	1.5	–	6.0	
I <sub>OFF</sub>	Power Off Leakage	A = 0 to 3.6 V, B = 0 to 3.6 V	A, B	0	0	–	0.02	1.5	–	5.0	$\mu$ A
				0.9–3.6	0	–	0.01	1.5	–	5.0	
				0	0.9–3.6	–	0.01	1.5	–	5.0	

Product parametric performance is indicated in the Electrical Characteristics for the listed test conditions, unless otherwise noted. Product performance may not be indicated by the Electrical Characteristics if operated under different conditions.

1. Normal test conditions are V<sub>I</sub> = 0 V, C<sub>LA</sub>  $\leq$  15 pF and C<sub>LB</sub>  $\leq$  15 pF, unless otherwise specified.

2. Typical values are for T<sub>A</sub> = +25°C. All units are production tested at T<sub>A</sub> = +25°C. Limits over the operating temperature range are guaranteed by design.

# NLSX5004, NLSXN5004

**Table 4. TIMING CHARACTERISTICS**

Symbol	Parameter	Test Conditions (Note 3)	V <sub>CCA</sub> (V)	V <sub>CCB</sub> (V)	-40°C to +85°C			-40°C to +125°C		Unit	
					Min	Typ (Note 4)	Max	Min	Max		
t <sub>PD</sub>	Propagation Delay	C <sub>L</sub> = 15 pF	A to B	0.9-3.6	0.9-3.6	-	8.8	30	-	35	ns
				1.2	1.8	-	7.3	9	-	9	
				1.8	1.2	-	9.9	12	-	12	
				1.8	2.8	-	4.9	7	-	7	
				2.8	1.8	-	5.8	7.5	-	7.5	
				1.8	3.3	-	4.6	6	-	6	
			B to A	3.3	1.8	-	5.7	7	-	7	
				1.8-3.6	1.8-3.6	-	4.3	9.5	-	10	
				0.9-3.6	0.9-3.6	-	8.8	30	-	35	
				1.2	1.8	-	9.9	12	-	12	
				1.8	1.2	-	7.3	9	-	9	
				1.8	2.8	-	5.8	7.5	-	7.5	
		C <sub>L</sub> = 30 pF	A to B	2.8	1.8	-	4.9	7	-	7	
				1.8	3.3	-	5.7	7	-	7	
				3.3	1.8	-	4.6	6	-	6	
				1.8-3.6	1.8-3.6	-	4.3	9.5	-	10	
				0.9-3.6	0.9-3.6	-	9.1	32	-	35	
				1.2	1.8	-	7.8	9.3	-	9.3	
			B to A	1.8	1.2	-	10.8	12.6	-	12.6	
				1.8	2.8	-	6.2	7.4	-	7.4	
				2.8	1.8	-	6.0	7.9	-	7.9	
				1.8	3.3	-	6.1	7.4	-	7.4	
				3.3	1.8	-	4.2	6.5	-	6.5	
				1.8-3.6	1.8-3.6	-	4.5	10	-	10.5	
		C <sub>L</sub> = 50 pF	A to B	0.9-3.6	0.9-3.6	-	9.1	32	-	35	
				1.2	1.8	-	10.8	12.6	-	12.6	
				1.8	1.2	-	7.8	9.3	-	9.3	
				1.8	2.8	-	6.0	7.9	-	8.0	
				2.8	1.8	-	6.2	7.4	-	7.4	
				1.8	3.3	-	4.2	6.5	-	6.5	
			B to A	3.3	1.8	-	6.1	7.4	-	7.4	
				1.8-3.6	1.8-3.6	-	4.5	10	-	10.5	
				0.9-3.6	0.9-3.6	-	9.4	35	-	37	
				1.2	1.8	-	8.1	9.5	-	9.5	
				1.8	1.2	-	11.1	13.6	-	13.6	
				1.8	2.8	-	6.5	7.6	-	7.6	
C <sub>L</sub> = 50 pF	A to B	2.8	1.8	-	6.2	8.2	-	8.3			
		1.8	3.3	-	6.3	7.6	-	7.6			
		3.3	1.8	-	4.3	6.6	-	6.6			
		1.8-3.6	1.8-3.6	-	4.7	10.3	-	10.8			
		0.9-3.6	0.9-3.6	-	9.4	35	-	37			
		1.2	1.8	-	11.1	13.6	-	13.6			
	B to A	1.8	1.2	-	8.1	9.5	-	9.5			
		1.8	2.8	-	6.2	8.2	-	8.3			
		2.8	1.8	-	6.5	7.6	-	7.6			
		1.8	3.3	-	4.3	6.6	-	6.6			
		3.3	1.8	-	6.3	7.6	-	7.6			
		1.8-3.6	1.8-3.6	-	4.7	10.3	-	10.8			

3. Typical values are for T<sub>A</sub> = +25°C. Limits over the operating temperature range are guaranteed by design.

4. Guaranteed by design.

# NLSX5004, NLSXN5004

**Table 4. TIMING CHARACTERISTICS** (continued)

Symbol	Parameter	Test Conditions (Note 3)	V <sub>CCA</sub> (V)	V <sub>CCB</sub> (V)	-40°C to +85°C			-40°C to +125°C		Unit		
					Min	Typ (Note 4)	Max	Min	Max			
t <sub>PD</sub>	Propagation Delay	C <sub>L</sub> = 100 pF	A to B	0.9–3.6	0.9–3.6	–	9.9	–	–	–	ns	
				1.2	1.8	–	8.4	10	–	10		
				1.8	1.2	–	11.5	14	–	14		
				1.8	2.8	–	5.5	8.3	–	8.3		
				2.8	1.8	–	6.9	8.9	–	9.0		
				1.8	3.3	–	5.1	6.7	–	6.8		
				3.3	1.8	–	6.8	8.2	–	8.2		
			B to A	1.8–3.6	1.8–3.6	–	5.0	11	–	11.5		
				0.9–3.6	0.9–3.6	–	9.9	–	–	–		
				1.2	1.8	–	11.5	14	–	14		
				1.8	1.2	–	8.4	10	–	10		
				1.8	2.8	–	6.9	8.9	–	9.0		
				2.8	1.8	–	5.5	8.3	–	8.3		
				1.8	3.3	–	6.8	8.2	–	8.2		
t <sub>R</sub>	Output Rise Time	C <sub>L</sub> = 15 pF	A	0.9–1.2	0.9–3.6	–	2.5	4.5	–	4.5	ns	
				1.2–1.8		–	2.0	3.0	–	3.0		
				1.8–2.8		–	0.6	2.0	–	2.0		
				2.8–3.6		–	0.5	2.5	–	2.5		
			B	0.9–3.6	0.9–1.2	–	2.5	4.5	–	4.5		
				1.2–1.8	–	2.0	3.0	–	3.0			
				1.8–2.8	–	0.6	2.0	–	2.0			
				2.8–3.6	–	0.5	2.5	–	2.5			
t <sub>F</sub>	Output Fall Time	C <sub>L</sub> = 15 pF	A	0.9–1.2	0.9–3.6	–	2.5	6.0	–	6.0	ns	
				1.2–1.8		–	1.8	3.0	–	3.0		
				1.8–2.8		–	0.6	2.0	–	2.0		
				2.8–3.6		–	0.5	2.5	–	2.5		
			B	0.9–3.6	0.9–1.2	–	2.5	6.0	–	6.0		
				1.2–1.8	–	1.8	3.0	–	3.0			
				1.8–2.8	–	0.6	2.0	–	2.0			
				2.8–3.6	–	0.5	2.5	–	2.5			
t <sub>SK</sub>	Channel-to-Channel Skew		0.9–3.6	0.9–3.6	–	–	0.15	–	0.15	ns		
MDR	Maximum Data Rate	C <sub>L</sub> = 15 pF	0.9–3.6	0.9–3.6	50	–	–	50	–	Mbps		
			1.8–3.6	1.8–3.6	140	–	–	140	–			
		C <sub>L</sub> = 30 pF	0.9–3.6	0.9–3.6	40	–	–	40	–			
			1.8–3.6	1.8–3.6	120	–	–	120	–			
		C <sub>L</sub> = 50 pF	0.9–3.6	0.9–3.6	30	–	–	30	–			
			1.8–3.6	1.8–3.6	100	–	–	100	–			
C <sub>L</sub> = 100 pF	0.9–3.6	0.9–3.6	20	–	–	20	–					
	1.8–3.6	1.8–3.6	60	–	–	60	–					
I <sub>I_PEAK</sub>	Input Driver Peak Current	EN = V <sub>CCA</sub> or EN = 0 V										
		A = 1 MHz Sq Wave, Amplitude = V <sub>CCA</sub>	A	0.9–3.6	0.9–3.6	–	–	5.0	–	5.0	mA	
		B = 1 MHz Sq Wave, Amplitude = V <sub>CCB</sub>	B	0.9–3.6	0.9–3.6	–	–	5.0	–	5.0		

3. Typical values are for T<sub>A</sub> = +25°C. Limits over the operating temperature range are guaranteed by design.

4. Guaranteed by design.

# NLSX5004, NLSXN5004

**Table 4. TIMING CHARACTERISTICS** (continued)

Symbol	Parameter	Test Conditions (Note 3)	V <sub>CCA</sub> (V)	V <sub>CCB</sub> (V)	-40°C to +85°C			-40°C to +125°C		Unit					
					Min	Typ (Note 4)	Max	Min	Max						
Z <sub>O</sub> (Note 4)	1-Shot Output Impedance				A	0.9		37			Ω				
						1.8	0.9-3.6	20							
						3.6		10							
						B	0.9		37						
							1.8	0.9-3.6	20						
							3.6		10						
t <sub>EN</sub>	Output Enable Time	C <sub>L</sub> = 15 pF; B = V <sub>CCB</sub>	EN/ $\overline{\text{EN}}$ to A	0.9-3.6	0.9-3.6	-	116.3	200	-	200	ns				
				1.2-1.8	1.2-1.8	-	64.5	180	-	180					
				1.8-2.8	1.8-2.8	-	49.6	150	-	150					
				1.8-3.6	1.8-3.6	-	42.5	100	-	100					
				C <sub>L</sub> = 15 pF; B = 0 V	0.9-3.6	0.9-3.6	-	113.4	300	-		300			
					1.2-1.8	1.2-1.8	-	100	250	-		250			
					1.8-2.8	1.8-2.8	-	94.3	200	-		200			
				1.8-3.6	1.8-3.6	1.8-3.6	-	90.9	170	-		170			
					C <sub>L</sub> = 15 pF; A = V <sub>CCA</sub>	EN/ $\overline{\text{EN}}$ to B	0.9-3.6	0.9-3.6	-	116.3		200	-	200	ns
							1.2-1.8	1.2-1.8	-	64.5		180	-	180	
				1.8-2.8			1.8-2.8	-	49.6	150		-	150		
				1.8-3.6			1.8-3.6	-	42.5	100		-	100		
		C <sub>L</sub> = 15 pF; A = 0 V	0.9-3.6	0.9-3.6			-	113.4	300	-	300				
			1.2-1.8	1.2-1.8			-	100	250	-	250				
			1.8-2.8	1.8-2.8			-	94.3	200	-	200				
		1.8-3.6	1.8-3.6	1.8-3.6			-	90.9	170	-	170				
			C <sub>L</sub> = 15 pF; B = V <sub>CCB</sub>	EN/ $\overline{\text{EN}}$ to A			0.9-3.6	0.9-3.6	-	255	600	-	600	ns	
							1.2-1.8	1.2-1.8	-	180	350	-	350		
		1.8-2.8					1.8-2.8	-	166.7	350	-	350			
		1.8-3.6					1.8-3.6	-	155.6	300	-	300			
		C <sub>L</sub> = 15 pF; B = 0 V			0.9-3.6	0.9-3.6	-	156.7	400	-	400				
					1.2-1.8	1.2-1.8	-	140	300	-	300				
					1.8-2.8	1.8-2.8	-	130.2	300	-	300				
		1.8-3.6			1.8-3.6	1.8-3.6	-	124.6	250	-	250				
C <sub>L</sub> = 15 pF; A = V <sub>CCA</sub>	EN/ $\overline{\text{EN}}$ to B				0.9-3.6	0.9-3.6	-	255	600	-	600	ns			
					1.2-1.8	1.2-1.8	-	180	350	-	350				
		1.8-2.8			1.8-2.8	-	166.7	350	-	350					
		1.8-3.6			1.8-3.6	-	155.6	300	-	300					
		C <sub>L</sub> = 15 pF; A = 0 V	0.9-3.6	0.9-3.6	-	156.7	400	-	400						
			1.2-1.8	1.2-1.8	-	140	300	-	300						
			1.8-2.8	1.8-2.8	-	130.2	300	-	300						
		1.8-3.6	1.8-3.6	1.8-3.6	-	124.6	250	-	250						

3. Typical values are for T<sub>A</sub> = +25°C. Limits over the operating temperature range are guaranteed by design.

4. Guaranteed by design.

# NLSX5004, NLSXN5004

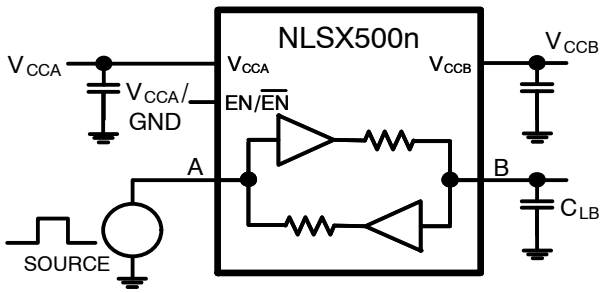

Figure 8. Driving A-Port Test Circuit ( $t_{PD}$ )

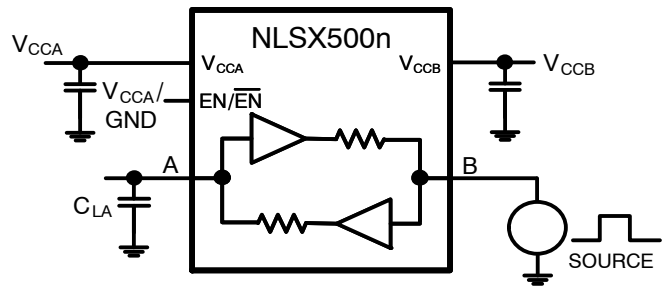

Figure 9. Driving B-Port Test Circuit ( $t_{PD}$ )

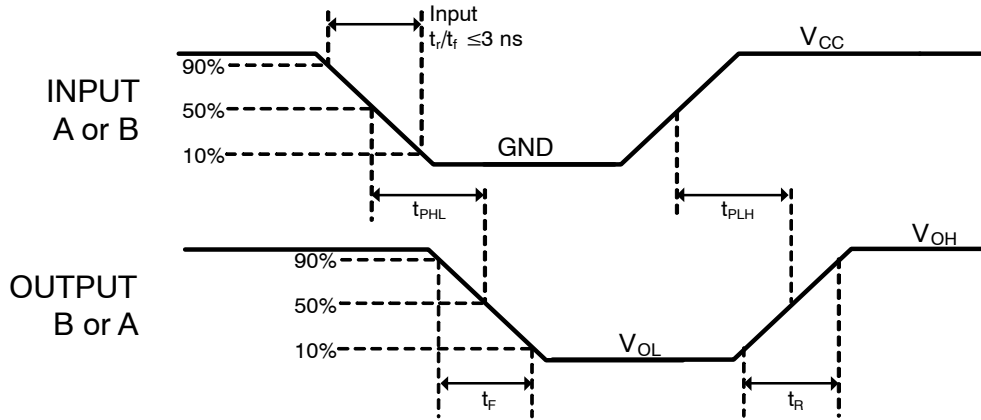

Figure 10.  $t_{PD}$  ( $t_{PLH}/t_{PHL}$ ) Propagation Delay Measurements

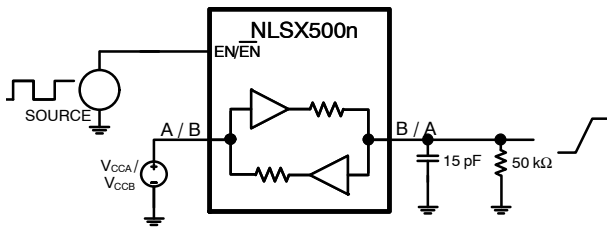

Figure 11. Enable/Disable Test Circuit ( $t_{PZH}/t_{PHZ}$ )

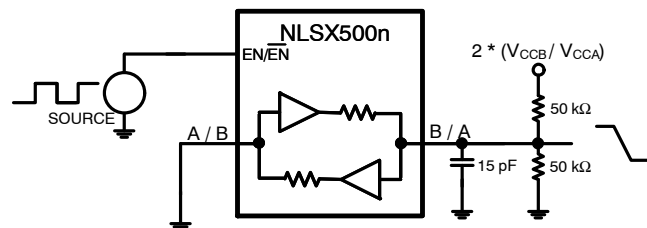

Figure 12. Enable/Disable Test Circuit ( $t_{PZL}/t_{PLZ}$ )

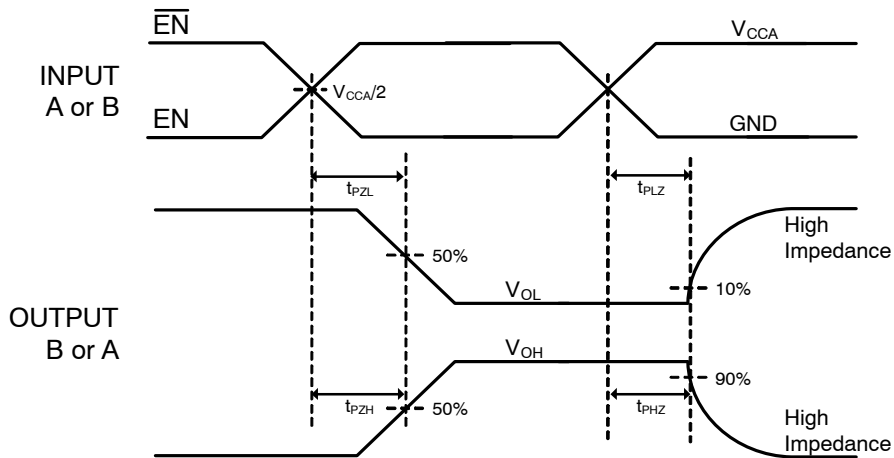

Figure 13.  $t_{EN}/t_{DIS}$  ( $t_{PZL}/t_{PLZ}/t_{PZH}/t_{PHZ}$ ) Propagation Delay Measurements

## IMPORTANT APPLICATIONS INFORMATION

### Level Translator Architecture

The NLSX5004 and the NLSXN5004 auto-sense translators provide bi-directional logic voltage level shifting to transfer data in multiple supply voltage systems. These level translators have two supply voltages,  $V_{CCA}$  and  $V_{CCB}$ , which set the logic levels on the input and output sides of the translator. When used to transfer data from the A to the B ports, input signals referenced to the  $V_{CCA}$  supply are translated to output signals with a logic level matched to  $V_{CCB}$ . In a similar manner, the B to A translation shifts input signals with a logic level compatible to  $V_{CCB}$  to an output signal matched to  $V_{CCA}$ .

The NLSX5004 and the NLSXN5004 translators consist of bi-directional channels that independently determine the direction of the data flow without requiring a directional pin. One-shot circuits are used to detect the rising or falling input signals. In addition, the one-shots decrease the rise and fall times of the output signal for high-to-low and low-to-high transitions.

### Input Driver Requirements

The NLSX5004 and NLSXN5004 support high data rates, but these translators have relatively modest DC output current drive. The high data rate of the bi-directional I/O circuit is used to quickly transform from an input to an output driver and vice versa. Each I/O port has a modest DC current output so that the internal output driver can be over-driven when data is sent in the opposite direction. For proper operation, the input driver to the auto-sense translator should be capable of driving 5.0 mA of peak output current. The bi-directional configuration of the translator results in both input stages being active for a very short time period. Although the peak current required from the input signal circuit is relatively large, the average current is small and consistent with a standard CMOS input stage.

### Enable Input (EN/ $\overline{EN}$ )

The NLSX5004 and NLSXN5004 translators have enable pins that provide tri-state operation at the I/O ports.

Driving the NLSX5004 Enable pin (EN) to a low logic level minimizes the power consumption of the device and drives the A- and B-ports to high impedance states. Normal translation operation occurs when the EN pin is equal to a logic high signal.

Driving NLSXN5004 Enable pin ( $\overline{EN}$ ) to a high logic level minimizes the power consumption of the device and drives the A- and B-ports to high impedance states. Normal translation operation occurs when the  $\overline{EN}$  pin is equal to a logic low signal.

Both EN and  $\overline{EN}$  pins are referenced to the  $V_{CCA}$  supply and are Over-Voltage Tolerant (OVT).

### Uni-Directional versus Bi-Directional Translation

The NLSX5004 and NLSXN5004 translators can function as non-inverting uni-directional translators. One advantage of using these translators as uni-directional devices is that each I/O-port can be configured as either an input or an output. The configurable input or output feature is especially useful in applications such as SPI that use multiple uni-directional I/O lines to send data to and from a device. The flexible I/O port of the auto sense translator simplifies the trace connections on the PCB.

### Power Supply Guidelines

The values of the  $V_{CCA}$  and  $V_{CCB}$  supplies can be set to anywhere between 0.9 and 3.6 V. Design flexibility is maximized because  $V_{CCA}$  may be either greater than, equal to or less than the  $V_{CCB}$  supply.

The sequencing of the power supplies will not damage the device during power-up operation. In addition, the A- and B-ports are in high impedance states if either supply voltage is equal to 0 V. For optimal performance, 0.01 to 0.1  $\mu$ F decoupling capacitors should be used on the  $V_{CCA}$  and  $V_{CCB}$  power supply pins. Ceramic capacitors are a good design choice to filter and bypass any noise signals on the voltage lines to the ground plane of the PCB. The noise immunity will be maximized by placing the capacitors as close as possible to the supply and ground pins, along with minimizing the PCB connection traces.

## NLSX5004, NLSXN5004

### DEVICE ORDERING INFORMATION

Device Order Number	Package Type	Tape & Reel Size†
NLSX5004MUTAG	UQFN-12	3000 Units/Reel
NLVSX5004MUTAG*	UQFN-12	3000 Units/Reel
NLSX5004DR2G (In Development)	SOIC14	2500 Units/Reel
NLVSX5004DR2G* (In Development)	SOIC14	2500 Units/Reel
NLSX5004DTR2G (In Development)	TSSOP14	2500 Units/Reel
NLVSX5004DTR2G* (In Development)	TSSOP14	2500 Units/Reel
NLSX5004MN1TXG (In Development)	QFN14, 3.5 x 3.5 x 0.5P	3000 Units/Reel
NLVSX5004MN1TXG* (In Development)	QFN14, 3.5 x 3.5 x 0.5P	3000 Units/Reel
NLSX5004MN1TWG (In Development)	QFN14, 2.5 x 3.0 x 0.5P	3000 Units/Reel
NLVSX5004MN1TWG* (In Development)	QFN14, 2.5 x 3.0 x 0.5P	3000 Units/Reel
NLSXN5004MU2TAG (In Development)	UQFN-12	3000 Units/Reel
NLVSXN5004MU2TAG* (In Development)	UQFN-12	3000 Units/Reel
NLSXN5004DR2G (In Development)	SOIC14	2500 Units/Reel
NLVSXN5004DR2G* (In Development)	SOIC14	2500 Units/Reel
NLSXN5004DTR2G (In Development)	TSSOP14	2500 Units/Reel
NLVSXN5004DTR2G* (In Development)	TSSOP14	2500 Units/Reel
NLSXN5004MN1TXG (In Development)	QFN14, 3.5 x 3.5 x 0.5P	3000 Units/Reel
NLVSXN5004MN1TXG* (In Development)	QFN14, 3.5 x 3.5 x 0.5P	3000 Units/Reel
NLSXN5004MN1TWG (In Development)	QFN14, 2.5 x 3.0 x 0.5P	3000 Units/Reel
NLVSXN5004MN1TWG* (In Development)	QFN14, 2.5 x 3.0 x 0.5P	3000 Units/Reel

†For information on tape and reel specifications, including part orientation and tape sizes, please refer to our Tape and Reel Packaging Specifications Brochure, BRD8011/D.

\*NLV Prefix for Automotive and Other Applications Requiring Unique Site and Control Change Requirements; AEC-Q100 Qualified and PPAP Capable

# NLSX5004, NLSXN5004

## PACKAGE DIMENSIONS

### UQFN12 1.7x2.0, 0.4P CASE 523AE ISSUE A

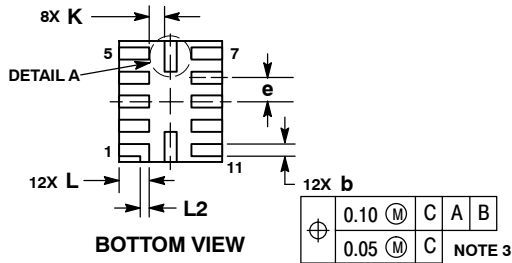
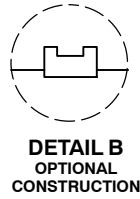
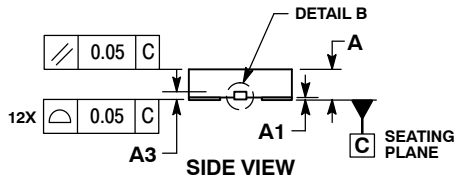
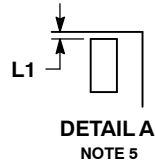
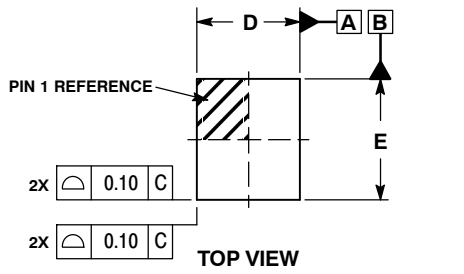

**NOTES:**

1. DIMENSIONING AND TOLERANCING PER ASME Y14.5M, 1994.
2. CONTROLLING DIMENSION: MILLIMETERS
3. DIMENSION b APPLIES TO PLATED TERMINAL AND IS MEASURED BETWEEN 0.15 AND 0.30 MM FROM TERMINAL TIP.
4. MOLD FLASH ALLOWED ON TERMINALS ALONG EDGE OF PACKAGE. FLASH 0.03 MAX ON BOTTOM SURFACE OF TERMINALS.
5. DETAIL A SHOWS OPTIONAL CONSTRUCTION FOR TERMINALS.

DIM	MILLIMETERS	
	MIN	MAX
A	0.45	0.55
A1	0.00	0.05
A3	0.127 REF	
b	0.15	0.25
D	1.70 BSC	
E	2.00 BSC	
e	0.40 BSC	
K	0.20	---
L	0.45	0.55
L1	0.00	0.03
L2	0.15 REF	

### MOUNTING FOOTPRINT SOLDERMASK DEFINED

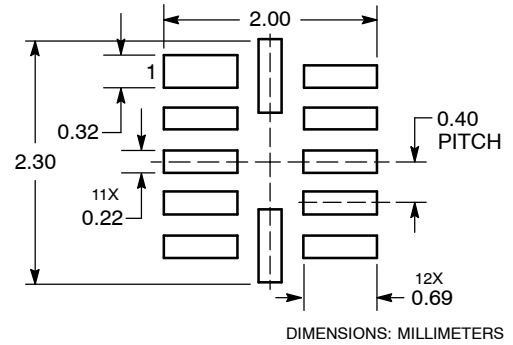

# NLSX5004, NLSXN5004

## PACKAGE DIMENSIONS

### SOIC-14 NB CASE 751A-03 ISSUE L

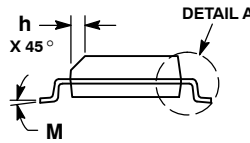
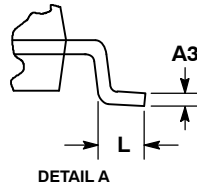
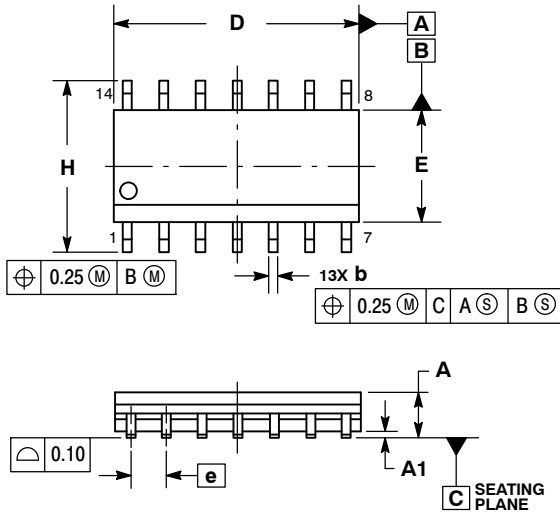

NOTES:

1. DIMENSIONING AND TOLERANCING PER ASME Y14.5M, 1994.
2. CONTROLLING DIMENSION: MILLIMETERS.
3. DIMENSION b DOES NOT INCLUDE DAMBAR PROTRUSION. ALLOWABLE PROTRUSION SHALL BE 0.13 TOTAL IN EXCESS OF AT MAXIMUM MATERIAL CONDITION.
4. DIMENSIONS D AND E DO NOT INCLUDE MOLD PROTRUSIONS.
5. MAXIMUM MOLD PROTRUSION 0.15 PER SIDE.

DIM	MILLIMETERS		INCHES	
	MIN	MAX	MIN	MAX
A	1.35	1.75	0.054	0.068
A1	0.10	0.25	0.004	0.010
A3	0.19	0.25	0.008	0.010
b	0.35	0.49	0.014	0.019
D	8.55	8.75	0.337	0.344
E	3.80	4.00	0.150	0.157
e	1.27 BSC		0.050 BSC	
H	5.80	6.20	0.228	0.244
h	0.25	0.50	0.010	0.019
L	0.40	1.25	0.016	0.049
M	0°	7°	0°	7°

### SOLDERING FOOTPRINT\*

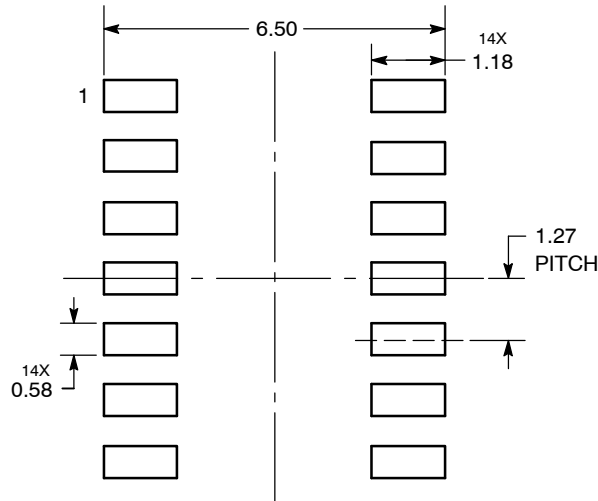

DIMENSIONS: MILLIMETERS

\*For additional information on our Pb-Free strategy and soldering details, please download the ON Semiconductor Soldering and Mounting Techniques Reference Manual, SOLDERRM/D.

# NLSX5004, NLSXN5004

## PACKAGE DIMENSIONS

### TSSOP-14 WB CASE 948G ISSUE C

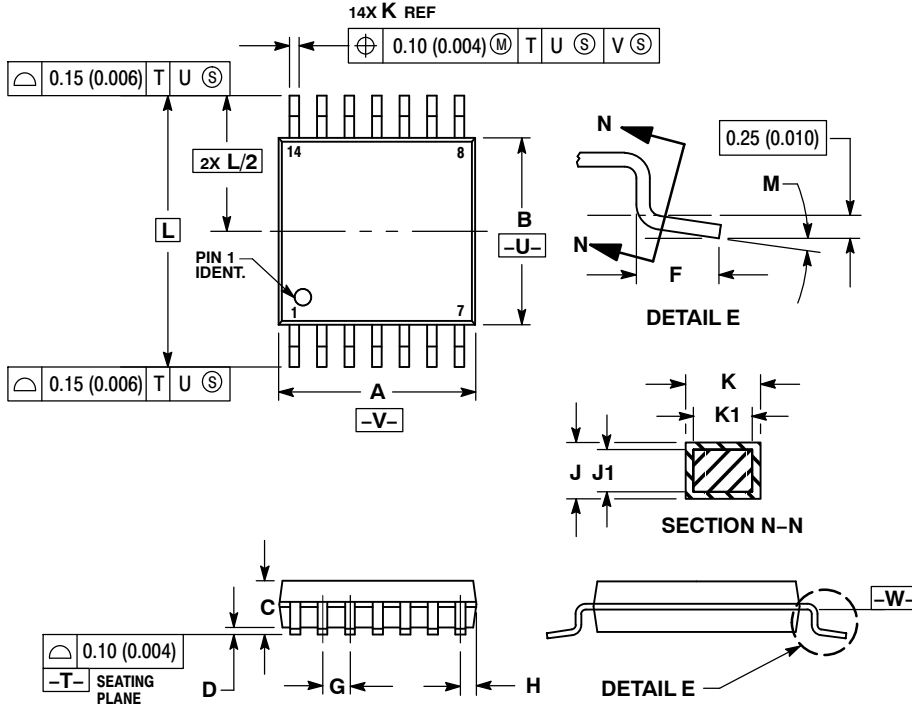

#### NOTES:

1. DIMENSIONING AND TOLERANCING PER ANSI Y14.5M, 1982.
2. CONTROLLING DIMENSION: MILLIMETER.
3. DIMENSION A DOES NOT INCLUDE MOLD FLASH, PROTRUSIONS OR GATE BURRS. MOLD FLASH OR GATE BURRS SHALL NOT EXCEED 0.15 (0.006) PER SIDE.
4. DIMENSION B DOES NOT INCLUDE INTERLEAD FLASH OR PROTRUSION. INTERLEAD FLASH OR PROTRUSION SHALL NOT EXCEED 0.25 (0.010) PER SIDE.
5. DIMENSION K DOES NOT INCLUDE DAMBAR PROTRUSION. ALLOWABLE DAMBAR PROTRUSION SHALL BE 0.08 (0.003) TOTAL IN EXCESS OF THE K DIMENSION AT MAXIMUM MATERIAL CONDITION.
6. TERMINAL NUMBERS ARE SHOWN FOR REFERENCE ONLY.
7. DIMENSION A AND B ARE TO BE DETERMINED AT DATUM PLANE -W-.

DIM	MILLIMETERS		INCHES	
	MIN	MAX	MIN	MAX
A	4.90	5.10	0.193	0.200
B	4.30	4.50	0.169	0.177
C	---	1.20	---	0.047
D	0.05	0.15	0.002	0.006
F	0.50	0.75	0.020	0.030
G	0.65 BSC		0.026 BSC	
H	0.50	0.60	0.020	0.024
J	0.09	0.20	0.004	0.008
J1	0.09	0.16	0.004	0.006
K	0.19	0.30	0.007	0.012
K1	0.19	0.25	0.007	0.010
L	6.40 BSC		0.252 BSC	
M	0°		8°	

### SOLDERING FOOTPRINT

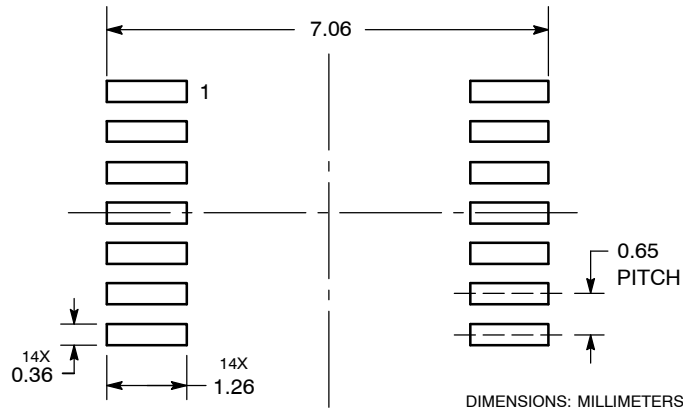

# NLSX5004, NLSXN5004

## PACKAGE DIMENSIONS

QFN14, 2.5x3.0, 0.5P  
CASE 485DE  
ISSUE O

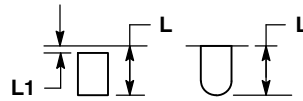
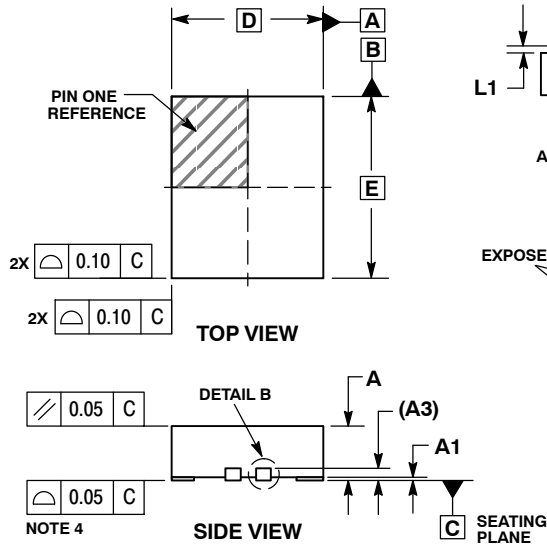

**DETAIL A**  
ALTERNATE TERMINAL  
CONSTRUCTIONS

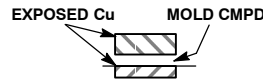

**DETAIL B**  
ALTERNATE  
CONSTRUCTIONS

**NOTES:**

1. DIMENSIONING AND TOLERANCING PER ASME Y14.5M, 1994.
2. CONTROLLING DIMENSION: MILLIMETERS.
3. DIMENSIONS b APPLIES TO PLATED TERMINAL AND IS MEASURED BETWEEN 0.15 AND 0.25MM FROM THE TERMINAL TIP.
4. COPLANARITY APPLIES TO THE EXPOSED PAD AS WELL AS THE TERMINALS.

MILLIMETERS		
DIM	MIN	MAX
A	0.80	1.00
A1	0.00	0.05
A3	0.20 REF	
b	0.20	0.30
D	2.50 BSC	
D2	0.90	1.10
E	3.00 BSC	
E2	1.40	1.60
e	0.50 BSC	
L	0.30	0.50
L1	---	0.05

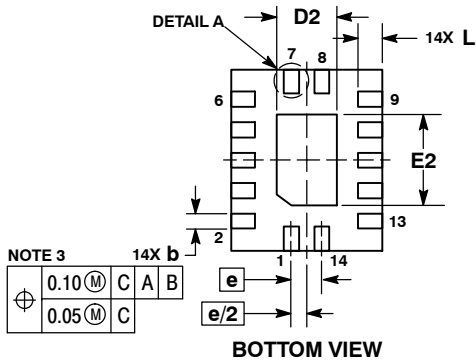

**RECOMMENDED  
SOLDERING FOOTPRINT\***

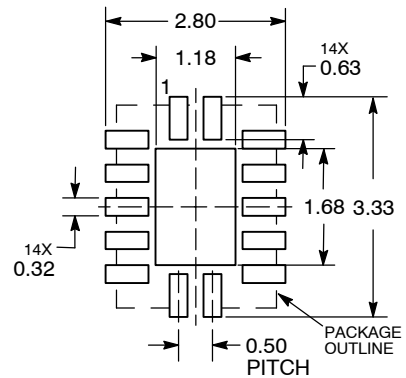

DIMENSIONS: MILLIMETERS

\*For additional information on our Pb-Free strategy and soldering details, please download the ON Semiconductor Soldering and Mounting Techniques Reference Manual, SOLDERRM/D.

# NLSX5004, NLSXN5004

## PACKAGE DIMENSIONS

### QFN14 3.5x3.5, 0.5P CASE 485AL ISSUE O

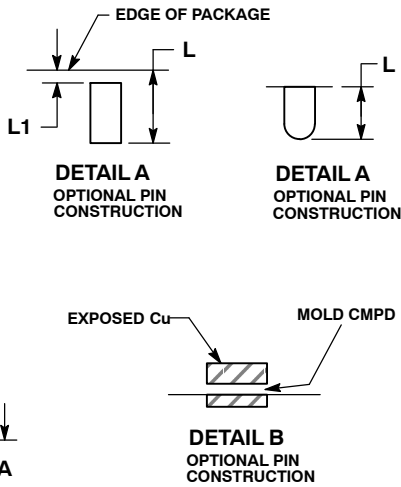
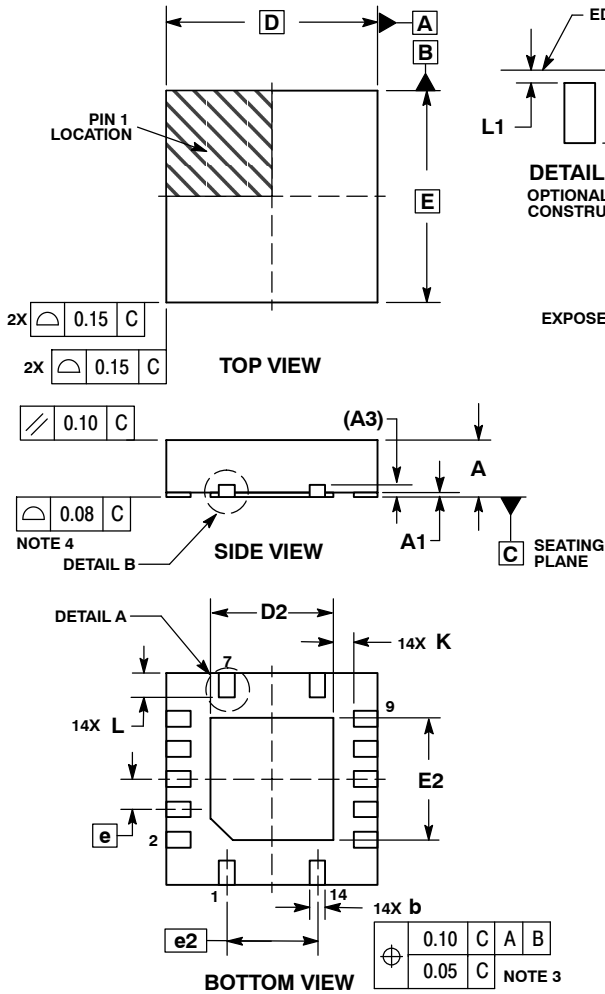

- NOTES:
1. DIMENSIONING AND TOLERANCING PER ASME Y14.5M, 1994.
  2. CONTROLLING DIMENSION: MILLIMETERS.
  3. DIMENSION b APPLIES TO PLATED TERMINAL AND IS MEASURED BETWEEN 0.15 AND 0.30 MM FROM TERMINAL TIP.
  4. COPLANARITY APPLIES TO THE EXPOSED PAD AS WELL AS THE TERMINALS.

DIM	MILLIMETERS	
	MIN	MAX
A	0.80	1.00
A1	0.00	0.05
A3	0.20 REF	
b	0.18	0.30
D	3.50 BSC	
D2	1.90	2.15
E	3.50 BSC	
E2	1.90	2.15
e	0.50 BSC	
e2	1.50 BSC	
K	0.20	---
L	0.30	0.50
L1	0.00	0.03

### SOLDERING FOOTPRINT\*

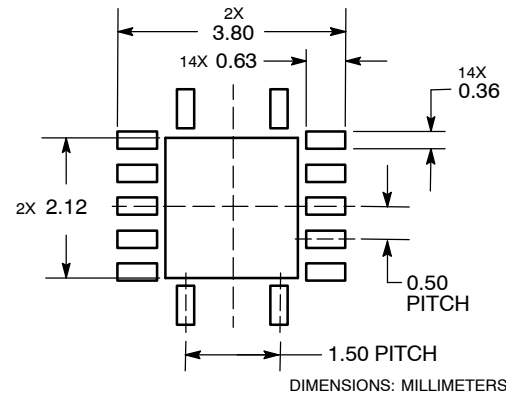

\*For additional information on our Pb-Free strategy and soldering details, please download the ON Semiconductor Soldering and Mounting Techniques Reference Manual, SOLDERRM/D.

ON Semiconductor and are trademarks of Semiconductor Components Industries, LLC dba ON Semiconductor or its subsidiaries in the United States and/or other countries. ON Semiconductor owns the rights to a number of patents, trademarks, copyrights, trade secrets, and other intellectual property. A listing of ON Semiconductor's product/patent coverage may be accessed at [www.onsemi.com/site/pdf/Patent-Marketing.pdf](http://www.onsemi.com/site/pdf/Patent-Marketing.pdf). ON Semiconductor reserves the right to make changes without further notice to any products herein. ON Semiconductor makes no warranty, representation or guarantee regarding the suitability of its products for any particular purpose, nor does ON Semiconductor assume any liability arising out of the application or use of any product or circuit, and specifically disclaims any and all liability, including without limitation special, consequential or incidental damages. Buyer is responsible for its products and applications using ON Semiconductor products, including compliance with all laws, regulations and safety requirements or standards, regardless of any support or applications information provided by ON Semiconductor. "Typical" parameters which may be provided in ON Semiconductor data sheets and/or specifications can and do vary in different applications and actual performance may vary over time. All operating parameters, including "Typicals" must be validated for each customer application by customer's technical experts. ON Semiconductor does not convey any license under its patent rights nor the rights of others. ON Semiconductor products are not designed, intended, or authorized for use as a critical component in life support systems or any FDA Class 3 medical devices or medical devices with a same or similar classification in a foreign jurisdiction or any devices intended for implantation in the human body. Should Buyer purchase or use ON Semiconductor products for any such unintended or unauthorized application, Buyer shall indemnify and hold ON Semiconductor and its officers, employees, subsidiaries, affiliates, and distributors harmless against all claims, costs, damages, and expenses, and reasonable attorney fees arising out of, directly or indirectly, any claim of personal injury or death associated with such unintended or unauthorized use, even if such claim alleges that ON Semiconductor was negligent regarding the design or manufacture of the part. ON Semiconductor is an Equal Opportunity/Affirmative Action Employer. This literature is subject to all applicable copyright laws and is not for resale in any manner.

### PUBLICATION ORDERING INFORMATION

**LITERATURE FULFILLMENT:**  
Literature Distribution Center for ON Semiconductor  
19521 E. 32nd Pkwy, Aurora, Colorado 80011 USA  
**Phone:** 303-675-2175 or 800-344-3860 Toll Free USA/Canada  
**Fax:** 303-675-2176 or 800-344-3867 Toll Free USA/Canada  
**Email:** [orderlit@onsemi.com](mailto:orderlit@onsemi.com)

**N. American Technical Support:** 800-282-9855 Toll Free  
USA/Canada  
**Europe, Middle East and Africa Technical Support:**  
Phone: 421 33 790 2910

**ON Semiconductor Website:** [www.onsemi.com](http://www.onsemi.com)  
**Order Literature:** <http://www.onsemi.com/orderlit>

For additional information, please contact your local Sales Representative

# Mouser Electronics

Authorized Distributor

Click to View Pricing, Inventory, Delivery & Lifecycle Information:

[ON Semiconductor:](#)

[NLSX5004MUTAG](#) [NLVSX5004MUTAG](#)