

# NCV7430

## Automotive LIN RGB LED Driver

The NCV7430 is a single-chip RGB driver intended for dedicated multicolor LED applications. The RGB LED driver contains a LIN interface (slave) for parametric programming of LED color and intensity.

The device receives instructions through the LIN bus and subsequently drives the LEDs independently.

The NCV7430 acts as a slave on the LIN bus and the master can request specific status information (parameter values and error flags). The LIN address of the NCV7430 can be programmed in the internal memory of the device.

The NCV7430 is fully compatible with automotive requirements.

### PRODUCT FEATURES

#### LED Driver

- 3 Independent LED Current Regulators
- LED Currents Adjustable with External Resistors
- Power Dissipation Option with External Ballast Transistor

#### Controller with One-Time-Programmable Memory (OTP)

- LED Modulation Controller for 3 LEDs
- Full LED Calibration Support
  - ◆ Internal LED Color Calibration via Matrix Calculation
  - ◆ Intensity Control (linear or logarithmic)
  - ◆ Dimming and Color Transition (linear) Function with Programmable Transition Time

#### LIN Interface

- LIN Physical Layer according to LIN 2.1/ SAE J2602
- OTP-programmable Device Node Number
- OTP-programmable Group Address
- Diagnostics and Status Information
- LIN Bus Short Circuit Protection to Supply and Ground

#### Protection and Diagnostics

- Overcurrent Detection
- Short Circuit Detection to GND and VBB
- Open LED Detection
- High Temperature Warning and Shutdown
- Retry Mode on Error Detection

#### Power Saving

- Sleep Mode Supply Current 10  $\mu$ A
- Compliant with 14 V Automotive Systems

#### EMI Compatibility

- LIN Bus Integrated Slope Control
- EMC Reduced LED Modulation Mode

#### Quality

- NCV Prefix for Automotive and Other Applications Requiring Unique Site and Control Change Requirements; AEC-Q100 Qualified and PPAP Capable
- These Devices are Pb-Free and are RoHS Compliant



ON Semiconductor®

[www.onsemi.com](http://www.onsemi.com)

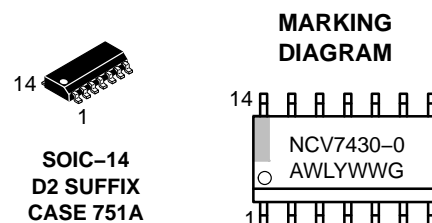

NCV7430 = Specific Device Code  
A = Assembly Location  
WL = Wafer Lot  
Y = Year  
WW = Work Week  
G = Pb-Free Package

### PIN CONNECTIONS

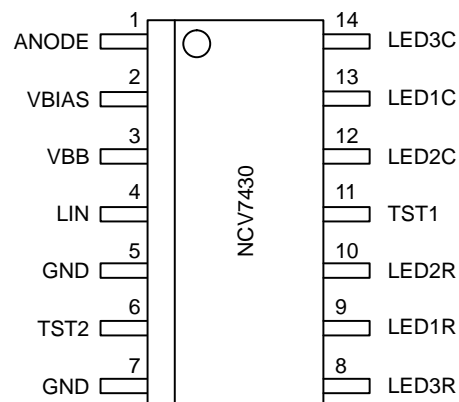

### ORDERING INFORMATION

Device	Package	Shipping†
NCV7430D20G	SOIC-14 (Pb-Free)	55 Units / Tube
NCV7430D20R2G	SOIC-14 (Pb-Free)	3000 / Tape & Reel

†For information on tape and reel specifications, including part orientation and tape sizes, please refer to our Tape and Reel Packaging Specification Brochure, BRD8011/D.

# NCV7430

## BLOCK DIAGRAM

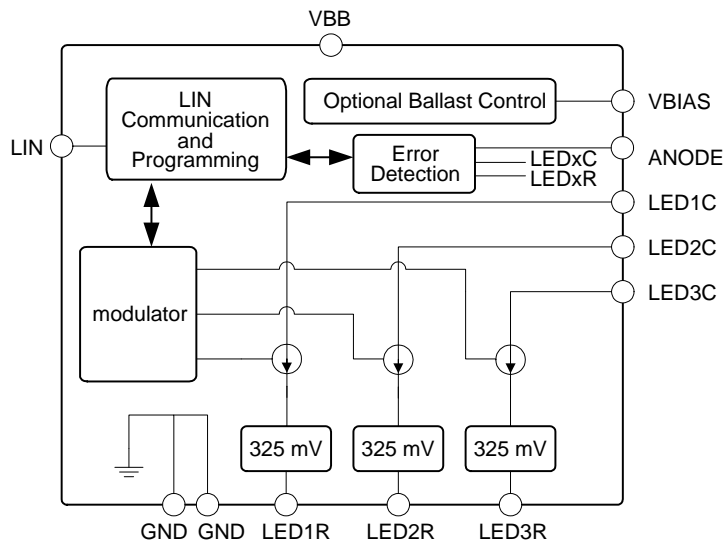

Figure 1. Simple Block Diagram

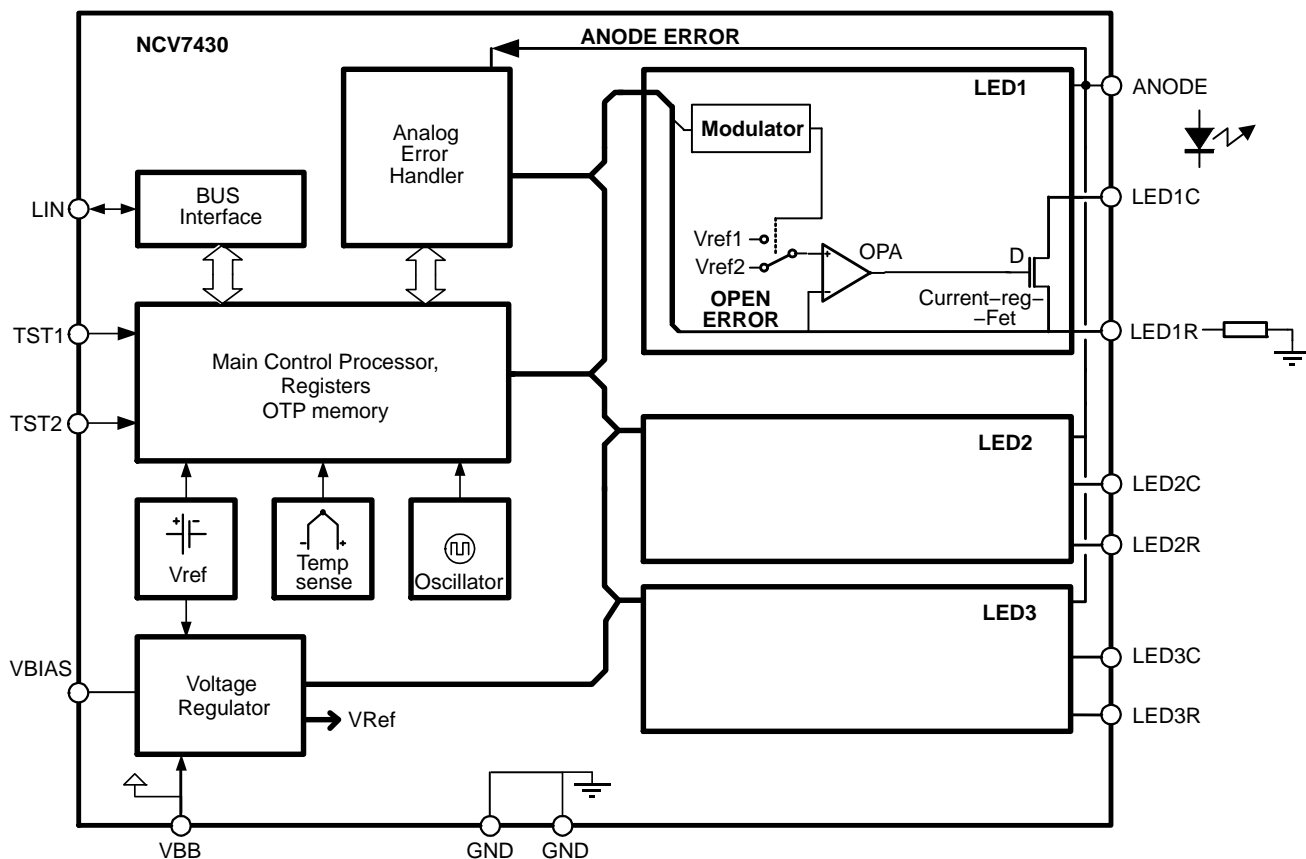

Figure 2. Detailed Block Diagram

# NCV7430

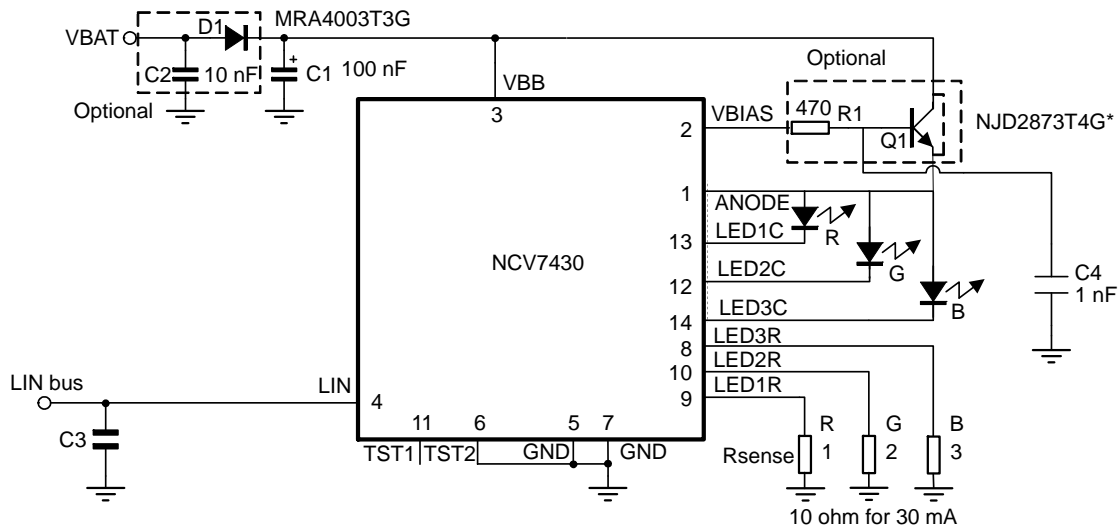

Figure 3. Typical Application with Ballast Transistor

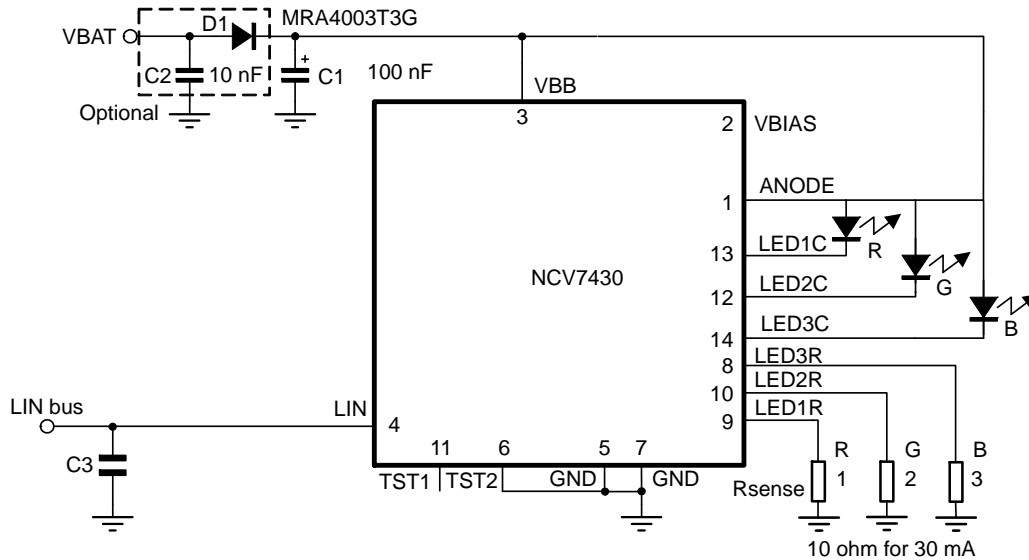

Figure 4. Typical Application without Ballast Transistor

**NOTES:**

- C<sub>1</sub> must be close to pins V<sub>BB</sub> and GND
- C<sub>2</sub> and C<sub>3</sub> is placed for EMC reasons; value depends on EMC requirements of the application
- R1 and Q1 and reverse polarity protection D1 and C2 are optional.
- When Q1 is not used, connect VBB to the ANODE pin. VBIAS output is kept open in this case.
- Rsense<sub>1</sub>, Rsense<sub>2</sub> and Rsense<sub>3</sub> have to be calculated for LED current settings.
- “R”, “G”, “B” designators refer to the ON Semiconductor evaluation board software associations.
- \* For lower power applications, a PZT3904T1G device can be substituted.
- RGB LED, OSRAM MULTILED LRTB GVSG or DOMINANT Multi DomiLED D6RTB-PJG

**Table 1. OPERATING RANGES**

Parameter		Min	Max	Unit
V <sub>BB</sub>	Supply voltage	+5.5	+18	V
T <sub>J</sub>	Operating temperature range	-40	+125	°C

# NCV7430

**Table 2. PIN FUNCTION DESCRIPTION** (14 LEAD SON Package)

Pin #	Label	Pin Description
1	ANODE	Anode input for LED fault detection
2	VBIAS	Bias output for ballast transistor
3	VBB	VBB (14 V) Supply Voltage
4	LIN	LIN–bus connection
5	GND	Supply GND
6	TST2	Test pin (ground pin)
7	GND	Supply GND
8	LED3R	Current program resistor to ground for LED3C
9	LED1R	Current program resistor to ground for LED1C
10	LED2R	Current program resistor to ground for LED2C
11	TST1	Test pin (float pin) (Note 1)
12	LED2C	Channel 2 regulated current output to LED cathode
13	LED1C	Channel 1 regulated current output to LED cathode
14	LED3C	Channel 3 regulated current output to LED cathode

1. Floating pin 11 eliminates the possibility of a short to ground of the adjacent pin (LED2C).

**Table 3. MAXIMUM RATINGS**

Parameter		Min	Max	Unit
V <sub>BB</sub>	Supply voltage	–0.3	+43 (Note 2)	V
	Supply voltage	–0.3	28 (Note 3)	V
V <sub>lin</sub>	Bus input voltage (LIN)	–45	+45	V
V <sub>VBIAS</sub>	Ballast Transistor Drive Voltage Pin (VBIAS)	–0.3	VANODE	V
I <sub>BIAS</sub>	Ballast Output Drive (VBIAS)	–	10	mA
V <sub>ANODE</sub>	LED Fault Sense Pin (ANODE) voltage	–0.3	VBB	V
V <sub>LEDC</sub>	LED Current Pin (LEDxC) voltage (Note 7)	–0.3	VBB	V
V <sub>LEDR</sub>	Program Current Pin (LEDxR) voltage (Note 4)	–0.3	3.6	V
T <sub>J</sub>	Junction temperature range (Note 5)	–50	+175	°C
T <sub>flw</sub>	Peak Reflow Soldering Temperature: Pb–Free 60 to 150 seconds at 217°C (Note 6)	–	260 peak	°C

Stresses exceeding those listed in the Maximum Ratings table may damage the device. If any of these limits are exceeded, device functionality should not be assumed, damage may occur and reliability may be affected.

- For limited time:  $t < 0.5$  s.
- $t < 3$  minutes
- V<sub>LEDR</sub> cannot exceed V<sub>LEDC</sub>.
- The circuit functionality is not fully guaranteed outside operating temperature range.
- For additional information, see or download ON Semiconductor's Soldering and Mounting Techniques Reference Manual, SOLDERRM/D, and Application Note AND8003/D.
- Capacitive loading on LEDxC pins is limited to  $< 200$  pF for proper functionality.

**Table 4. ATTRIBUTES**

Characteristics	Value
ESD Capability (Note 8)	Human Body Model (LIN Pin) Human Body Model (All Remaining Pins) Machine Model
Moisture Sensitivity Level (Note 6)	MSL 2
Storage Temperature	–55°C to 150°C
Package Thermal Resistance Junction–to–Ambient (R <sub>θJA</sub> ) (2S2P) (Note 9) Junction–to–Pin (R <sub>θJL</sub> ) (Pins 4 & 11)	100°K/W 53°K/W
Meets or exceeds JEDEC Spec EIA/JESD78 IC Latchup Test	

- HBM according to AEC–Q100: EIA–JESD22–A114–B (100 pF via 1.5 kΩ) and MM according to AEC–Q100: EIA–JESD22–A115–A.
- Simulated conform JEDEC JESD51

# NCV7430

**Table 5. ELECTRICAL CHARACTERISTICS** (5.5 V < V<sub>BB</sub> < 18 V, -40°C < T<sub>J</sub> < 125°C, R<sub>sense</sub> = 10 Ω TWPROG = TWPROG2 = 0, unless otherwise specified).

Symbol	Pin(s)	Characteristic	Conditions	Min	Typ	Max	Unit
<b>LED DRIVER</b>							
I <sub>LEDmax</sub>	LED1C LED2C	Single LED current in normal operation	V <sub>BB</sub> = 14 V For individual LED driven	-	-	32	mA
I <sub>LEDmaxTotal</sub>	LED3C	All LED currents in normal operation	V <sub>BB</sub> = 14 V For all LEDs driven	-	-	96	mA
I <sub>LEDx</sub> C		LED current	Uncalibrated Max ON Duty Cycle R <sub>SENSE</sub> = 10 Ω R <sub>SENSE</sub> = 100 Ω	28 2.8	30.5 3.05	32 3.2	mA
I <sub>MSabs</sub>		Absolute error on LED current	Calibrated V <sub>BB</sub> = 14 V, 3 mA < I <sub>LEDx</sub> C < 30 mA R <sub>SENSE</sub> = 10 Ω R <sub>SENSE</sub> = 100 Ω	-1 -3	- -	1 3	%
V <sub>Vref1</sub>		Reference voltage for current regulators (High) state	V <sub>BB</sub> = 14 V	-	325	-	mV
V <sub>Vref2</sub>		Reference voltage for current regulators (Low) state	V <sub>BB</sub> = 14 V	-	20	-	mV
<b>LIN TRANSMITTER</b>							
I <sub>bus_off</sub>	LIN	Dominant state, driver off	V <sub>linbus</sub> = 0 V, V <sub>BB</sub> = 8 V & 18 V	-1	-	-	mA
I <sub>bus_off</sub>		Recessive state, driver off	V <sub>linbus</sub> = V <sub>bat</sub> , V <sub>BB</sub> = 8 V & 18 V	-	-	20	μA
I <sub>bus_lim</sub>		Current limitation	V <sub>BB</sub> = 8 V & 18 V	40	75	200	mA
R <sub>slave</sub>		Pull-up resistance	V <sub>BB</sub> = 8 V & 18 V	20	30	47	kΩ
<b>LIN RECEIVER</b>							
V <sub>bus_dom</sub>	LIN	Receiver dominant state	V <sub>BB</sub> = 8 V & 18 V	0	-	0.4 * V <sub>BB</sub>	V
V <sub>bus_rec</sub>		Receiver recessive state	V <sub>BB</sub> = 8 V & 18 V	0.6 * V <sub>BB</sub>	-	V <sub>BB</sub>	V
V <sub>bus_hys</sub>		Receiver hysteresis	V <sub>BB</sub> = 8 V & 18 V	0.05 * V <sub>BB</sub>	-	0.175 * V <sub>BB</sub>	V
V <sub>rec_th_wake</sub>		LIN wake-up threshold	V <sub>BB</sub> = 8 V & 18 V	V <sub>BB</sub> - 1.1	-	V <sub>BB</sub> - 3.3	V
<b>THERMAL WARNING &amp; SHUTDOWN</b>							
T <sub>tw</sub>		Thermal warning (Notes 10, 11)		107	115	123	°C
T <sub>tw</sub> hyst		Thermal warning hysteresis		-	10	-	
T <sub>tsd</sub>		Thermal shutdown (Note 10)		147	155	163	°C
<b>THERMAL CONTROL</b>							
TH_Ired_step		LED Drive Current change at Thermal Warning		-	-6.25	-	% per step
<b>VBIAS OUTPUT</b>							
V <sub>bias</sub>		Output voltage	V <sub>BB</sub> = 14 V, I <sub>bias</sub> = 5 mA	7.3	-	8.3	V
<b>VBB SUPPLY</b>							
V <sub>BB_UV</sub>		VBB Undervoltage for LIN Communication		5.40	5.8	6.0	V

Product parametric performance is indicated in the Electrical Characteristics for the listed test conditions, unless otherwise noted. Product performance may not be indicated by the Electrical Characteristics if operated under different conditions.

10. Parameter guaranteed by trimming in production test.

11. No more than 2000 cumulative hours in life time above T<sub>w</sub>.

# NCV7430

**Table 5. ELECTRICAL CHARACTERISTICS** (5.5 V < V<sub>BB</sub> < 18 V, -40°C < T<sub>J</sub> < 125°C, R<sub>sense</sub> = 10 Ω TWPROG = TWPROG2 = 0, unless otherwise specified).

Symbol	Pin(s)	Characteristic	Conditions	Min	Typ	Max	Unit
<b>VBB SUPPLY</b>							
VBB_UV_hys		VBB Undervoltage Hysteresis for LIN Communication		–	0.2	0.4	V
PORH_V <sub>bb</sub>		Power-on Reset for output drive capability	Rising V <sub>bb</sub>	–	–	4.4	V
			Falling V <sub>bb</sub>	1.9	–	–	
V <sub>bb</sub> OTP	V <sub>BB</sub>	Supply voltage for OTP zapping		13	–	16	V
I <sub>bat</sub>		Total current consumption	Unloaded outputs V <sub>BB</sub> = 18 V, LEDs OFF	–	5.0	7.0	mA
I <sub>bat_sleep</sub>		Sleep mode current consumption	V <sub>BB</sub> = 13.5 V, T <sub>J</sub> = 85°C	–	10	20	μA

Product parametric performance is indicated in the Electrical Characteristics for the listed test conditions, unless otherwise noted. Product performance may not be indicated by the Electrical Characteristics if operated under different conditions.

10. Parameter guaranteed by trimming in production test.

11. No more than 2000 cumulative hours in life time above T<sub>w</sub>.

# NCV7430

## AC PARAMETERS

The AC parameters are guaranteed for temperature and  $V_{BB}$  in the operating range unless otherwise specified. The LIN transmitter and receiver physical layer parameters are compliant to LIN rev. 2.0 & 2.1.

**Table 6. AC CHARACTERISTICS**

Symbol	Pin(s)	Parameter	Test Conditions	Min	Typ	Max	Unit
<b>POWER-UP AND WAKE-UP</b>							
$t_{pu}$		Power-up time	Guaranteed by design	–	–	10	ms
$t_{LIN\_Wake}$		LIN Dominant Wake-up pulse filter time	Sleep mode	–	80	150	$\mu$ s
$t_{Wake}$		Reaction time after valid Wake-up pulse	Sleep mode	–	0.3	1	ms
$t_{Sleep\_to\_Normal}$		Sleep mode to Normal mode transition time	$t_{LIN\_Wake} > 150 \mu$ s Guaranteed by design	–	3	10	ms
<b>INTERNAL OSCILLATOR</b>							
$f_{osc}$		Frequency of internal oscillator	$V_{BB} = 14$ V	1.8	2	2.2	MHz
<b>LIN TRANSMITTER CHARACTERISTICS ACCORDING TO LIN v2.0 &amp; v2.1</b>							
D1	LIN	Duty cycle 1 $= (t_{Bus\_rec(min)} / (2 \times t_{Bit})) \times 100$ See Figure 5	$TH_{Rec(max)} = 0.744 \times V_{BB}$ $TH_{Dom(max)} = 0.581 \times V_{BB};$ $7.0$ V < $V_{BB} < 18$ V; $t_{Bit} = 50 \mu$ s	39.6	–	–	%
D2		Duty cycle 2 $= (t_{Bus\_rec(max)} / (2 \times t_{Bit})) \times 100$ See Figure 5	$TH_{Rec(min)} = 0.422 \times V_{BB}$ $TH_{Dom(min)} = 0.284 \times V_{BB};$ $7.6$ V < $V_{BB} < 18$ V; $t_{Bit} = 50 \mu$ s	–	–	58.1	%
<b>LED DRIVERS</b>							
$f_{LEDmodulation}$	LEDx	LED modulation frequency for MODFREQ = 0		117	122	127	Hz
		LED modulation frequency for MODFREQ = 1		234	244	254	
$t_{brise}$		Turn-on transient time	Between 10% and 90%	–	1	–	$\mu$ s
$t_{bfall}$		Turn-off transient time		–	1	–	$\mu$ s
$t_{LED\ settling}$		Settling time of Current regulators	Between 10% and 90% full scale	0.8	1	1.5	$\mu$ s
<b>THERMAL CONTROL</b>							
$t_{TH\_timeout}$		Timeout for current reduction after TW		–	10	–	s
<b>ERROR RETRY CONTROL</b>							
$t_{retryinterval}$		Intervaltime between retries		2.7	3	3.3	s
$N_{numberofretries}$		Number of retries before LEDs are switched off definitely		–	20	–	

# NCV7430

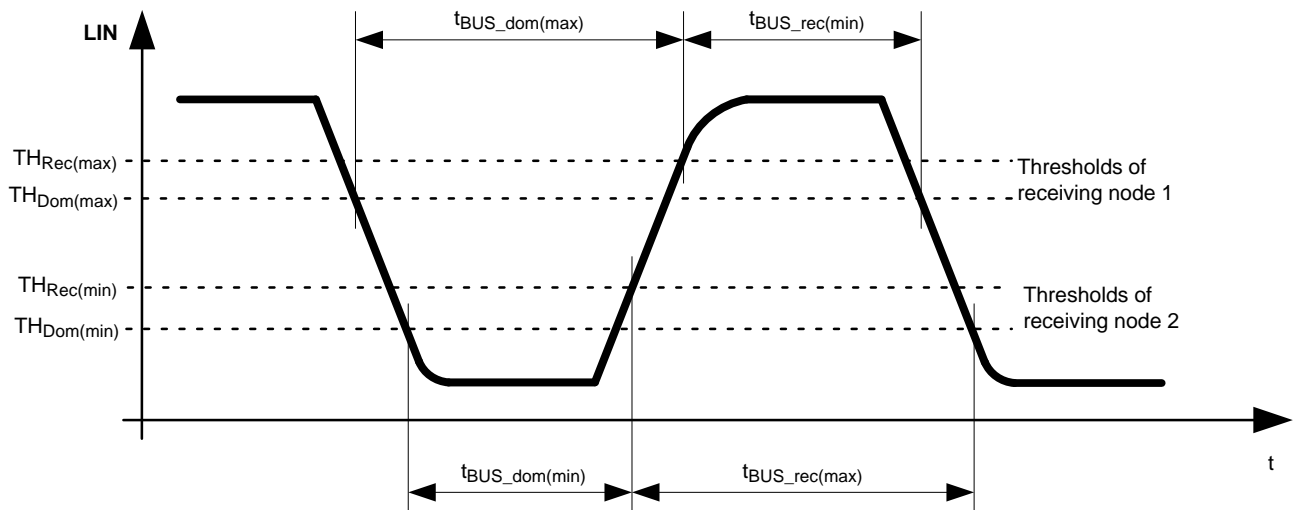

Figure 5. Timing for AC Characteristics According to LIN 2.0 and LIN 2.1

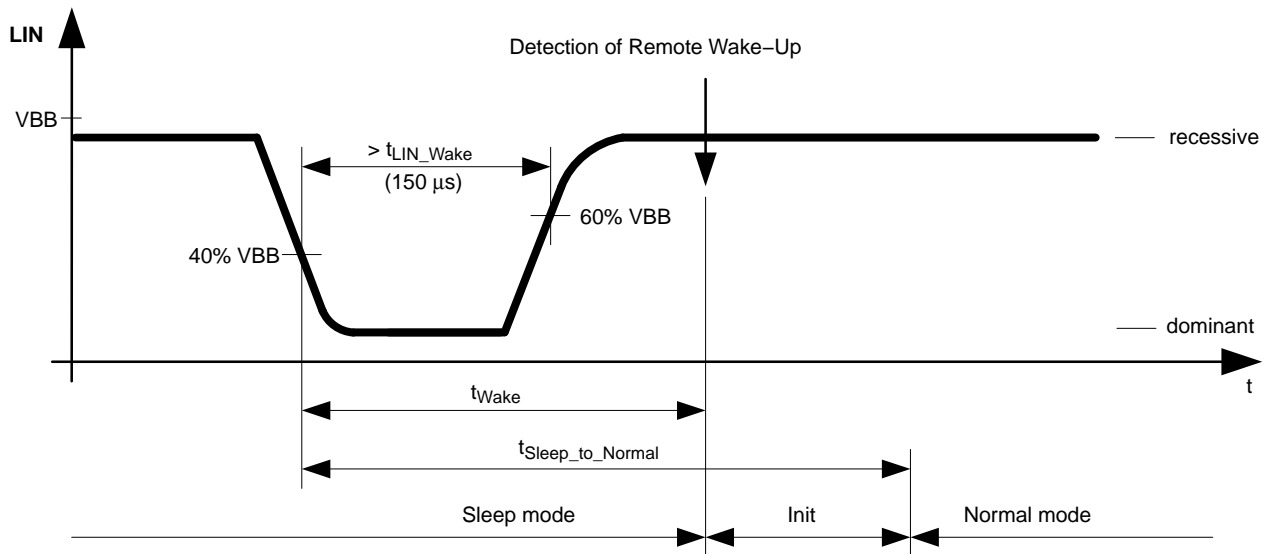

Figure 6. Timing for Wake Up from Sleep Mode via LIN Bus Transitions

## LIN Timing

### LIN Frames must be Sent in a Regular Manner

The internal oscillator is adapted to an accurate frequency based on the reception of multiple LIN synchronization fields. Although the NCV7430 is functional without LIN communication, the timing specifications cannot be guaranteed without periodic error-free LIN frame inputs.

### Detailed Operating Description

#### General

The NCV7430 is an automotive 3 channel LED driver suitable for use in a broad range of applications. Although designed to drive an RGB LED, it can easily be used to drive 3 independent LEDs. Each LED is driven by a constant current source externally programmed for maximum current using external resistors.

Precise color settings for RGB LEDs is achieved using independent current modulators. The three LED modulation controllers have eleven bit resolution with a choice of base frequencies of 122 Hz or 244 Hz.

#### System Operation

The programmability of the NCV7430 is achieved via a LIN bus interface. The device is operated in slave mode and accepts lighting instruction commands from a bus master. The physical node address of a slave can be programmed in OTP “address bits ADx” at address 0x03: For multi node operation the NCV7430 accepts broadcast commands. With the broadcast command and four additional “GROUP\_ID” bits programming of up to 16 different slave clusters can be done. In this approach each slave belongs to a specific cluster (GROUP).

NOTE: For the *Set\_Color\_Short* and *Set\_Intensity* commands the *GROUP\_ID* bits are split. The lower two bits are used to assign the NCV7430 to one of four groups for the color setting, while the upper two bits are used to assign the device to one of four groups for the intensity setting.

## Power-up

The NCV7430 powers up in an active mode. Reference the “Sleep Mode” section for low power standby conditions.

The device has a VBB Power-on Reset Level of 4.4 V, (max) for output drive capability. Operation of the device is guaranteed above the 4.4 V level. All integrated circuit activity will remain off prior to breaching the 4.4 V level. All output current sources (LEDxC), current programming pins (LEDxR), error detection pin (ANODE), ballast drive pin (VBIAS), and LIN communication pin (LIN) will be high impedance below 4.4 V. The device becomes fully operational above 4.4 V with the default parameters copied from OTP and will operate up to 18 V.

The <DEFAULT> bit in OTP determines if the LEDs are enabled or disabled on power-up.

The VBB Reset bit at Byte 4, Bit 4 in the Get\_Full\_Status In frame response 1 gets set to a one on Power-up and goes to “0” after the first Get\_Full\_Status command.

The minimum Power-on Reset Threshold is 1.9 V. The output drive is guaranteed to be inactive at or below this threshold.

NOTE: While LIN is operational for voltages at the minimum battery voltage level of 5.75 V (typ) (VBB Undervoltage), the LIN conformance is only guaranteed for a battery voltage higher than 8 V.

There is additional sensing of VBB with VBB Undervoltage detection (5.75 V) and is recorded at Byte 4, Bit 5 of the Get\_Full\_Status In frame response 1 and Byte 2, Bit 5 of Get\_Status In frame response. The LIN communication pin will not accept traffic during VBB Undervoltage, but will record the VBB undervoltage situation and can only be cleared with a Get\_Full\_Status frame.

## Current Sources

The NCV7430 has three independent analog current sources driving the LEDs. The currents are programmed by a fixed 325 mV voltage reference at the LEDxR pin. The delta current through the resistor resulting from  $V_{ref1} - V_{ref2}$ , equals the LED drive current at the LEDxC. Each maximum LED current (DC = Max ON) can be adjusted to a typical value up to 30.5 mA. The external resistor can be calculated as follows:

$$R = \frac{325 \text{ mV} - 20 \text{ mV}}{I_{LEDhigh}} \quad (\text{eq. 1})$$

For  $I_{LEDhigh} = 30.5 \text{ mA}$  the resistor is:

$$R = \frac{0.305 \text{ V}}{0.0305 \text{ A}} = 10 \Omega$$

When not being modulated for color setting purposes, or under abnormal or error conditions, the LEDs can be switched on and off independently by their <LEDx ENABLE> bit in the control register. Additionally, bit <LEDs ON/OFF> will activate and deactivate all LEDs at the same time. When there are error conditions, the LEDs will not turn on.

NOTE: The LED modulation current regulator switches between  $I_{LEDhigh}$  and a reduced current,  $I_{LEDlow}$ . The reduced current value is determined by a low reference voltage  $V_{ref2}$ . All references to Max ON duty cycle in this datasheet run at 2040/2048 duty cycle to provide for internal analog compensation.

## LED Modulation Sources

Each LED output has its own LED modulation controller. The NCV7430 blends the modulated LED currents in an RGB LED to create colors. The NCV7430 provides additional OTP registers for each channel to store color calibration factors. The calibration factors are used by the NCV7430 to create the modulation needed for an exact color setting.

The calibration functionality can be enabled and disabled via the CAL\_EN bit. If the CAL\_EN bit is ‘0’, the LIN command (8 bit) is save into the modulation registers. When the CAL\_EN is set to ‘1’, the received modulation values are first corrected, and then stored in the LED modulation registers.

For the calibration a matrix calculation is used. The matrix has the following form:

$$\begin{aligned} \text{LED1}' &= ((a_{11} + 1) \cdot \text{LED1} + (a_{12} + 0) \cdot \text{LED2} + (a_{13} + 0) \cdot \text{LED3})/32 \\ \text{LED2}' &= ((a_{21} + 0) \cdot \text{LED1} + (a_{22} + 1) \cdot \text{LED2} + (a_{23} + 0) \cdot \text{LED3})/32 \\ \text{LED3}' &= ((a_{31} + 0) \cdot \text{LED1} + (a_{32} + 0) \cdot \text{LED2} + (a_{33} + 1) \cdot \text{LED3})/32 \end{aligned} \quad (\text{eq. 2})$$

**LED Modulation Matrix**

The calibration factors have a value of eight bits and fraction the programmed LED modulation value between 0% and Max ON duty cycle.

With high values chosen for the coefficients in one row, the calculation can cross the Max ON duty cycle boundary (clipping) for the color. As a rule: For proper design, the sum of the calibration values should stay under Max ON duty cycle to prevent color saturation.

If one of the calculated LED1', LED2', or LED3' values exceeds the upper practical boundaries of Max ON duty cycle, the modulator automatically adapts the modulation speed to the color that exceeded the Max ON duty cycle. This method guarantees that the color integrity is maintained.

The calibration factors a11 to a33 reside in nine dedicated OTP registers:

(0x04 to 0x08, and 0x0A to 0x0D):

LED modulation Calibration data a11 to a33.

These registers can be programmed in OTP and are generally used for the compensation of LED colors which occur due to system design changes and lot-to-lot variation of LEDs.

### LED Intensity

The overall intensity of the LEDs is programmable with a four bit scaling factor that is applied over the LED modulation. The register containing this value is AMBLIGHTINTENSITY. The scaling is linear. The light output function is described with the following formula:

#### Intensity Matrix

$$\begin{Bmatrix} \text{LED1int} \\ \text{LED2int} \\ \text{LED3int} \end{Bmatrix} = \left( \frac{\text{AMBLIGHTINTENSITY}}{16} \right) * \begin{Bmatrix} \text{LED1}' \\ \text{LED2}' \\ \text{LED3}' \end{Bmatrix} \text{ (eq. 3)}$$

If the intensity value is set to 15 the used value for the calculation is 16, resulting in a multiplication factor of 1 (no intensity reduction). Changing the intensity from one to another value can follow a linear or logarithmic transition based on the fading time as described in "Theatre dimming function".

### LED Modulation Frequency

The LED modulation frequency can be chosen to be 122 or 244 Hz.

### Theatre Dimming Function

The NCV7430 has a fading function to give a theater dimming effect when changing color and/or intensity settings. The effect presents itself as a smooth transition between colors, or increases or decreases in intensity.

Transitions from color to color, or changes in intensity will vary in a linear fashion through the color/intensity spectrum (optional logarithmic mode for intensity). The fading time can be set between 0 and 6.3 seconds via a 6 bit register giving a resolution of 0.1 second. The fading function can be enabled and disabled by programming the FADING ON/OFF bit in the control registers. The default state of this bit depends on the <DEFAULT> bit that is set in OTP memory.

### Intensity – Linear or logarithmic dimming

#### Color – Linear dimming only

#### LED Update Modes

Bits <UPDATECOLOR[1:0]> are used to enable the NCV7430 for operation in different update modes. The following modes are implemented:

UPDATECOLOR:

00	immediate update
01	store and do not update
10	update to the already stored values
11	discard

The UPDATECOLOR bits are included in the command Set\_Color (Byte 5, Bits 6 and 7).

### Short Circuit and Open Circuit Detection

The NCV7430 provides protection features for each LED driver. The device monitors for LED Open Circuit (ANODE to LEDxC), LED Short Circuit (ANODE to LEDxC), Short LEDxC to GND and Open Circuit RSENSE (LEDxR to GND) as shown in Figure 7. Detection of these errors will set the appropriate error bits in the status register (<ERRLEDx[2:0]>), and proper action will be taken (reference Table 7).

There is a minimum detection activation time of 8 µsec for error detection (use of a 0.2% duty cycle is recommended). This is derived from a combination of color, intensity levels, and PWM frequency settings (122 Hz or 244 Hz). The system design should monitor error detection at high intensity settings to avoid missing short or open circuit conditions at low duty cycles. LEDxC shorts to ground do not require a minimum duty cycle.

Additionally, error detection must be sequential (transitioning from a known good state to an error state). Mixing of errors (i.e. transitioning from a short condition to an open condition) could result in signal false errors in identity.

Table 7. ERROR CONDITIONS FOR EACH INDIVIDUAL LED

Error Description:	ERR[2]	ERR[1]	ERR[0]	Retry Option <RETRYSTATE>	Action:
No Error	0	0	0	No	No Action
Open circuit LEDxR Short from ANODE to LEDxC	0	1	1	Yes	Thermal Sense
Short from LEDxC to GND (Note 13) "Shorted LED cathode to GND"	0	1	0	Yes	ANODE OFF (Note 12) LEDxC OFF
Open circuit (LEDxC to ANODE)	1	0	1	No	Thermal Sense
Thermal Shutdown				Automatic retry below Thermal Warning Threshold	LED & ANODE OFF (Note 12)

12. ANODE OFF is realized by internal circuitry that switches VBIAS to 0 V. The Anode can only be switched off when an external transistor is used.  
 13. A short from (LEDxC) to (LEDxR), or (ANODE) to (LEDxR) may damage the device. When the external ballast transistor is not used, the LED and/or Rsense may also be damaged.

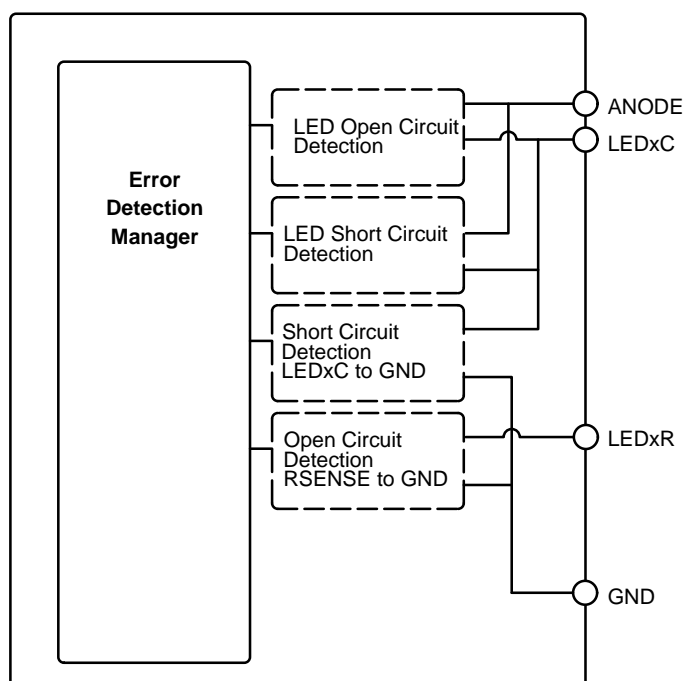

Figure 7. Short Circuit and Open Circuit Detection

**Thermal Warning and Thermal Shutdown**

The NCV7430 has thermal warning and thermal shutdown protection features. When the junction temperature of the NCV7430 rises above the thermal warning level ( $T_{<TW>}$ ), the  $<TW>$  warning flag is set in the status register. When the junction temperature rises above  $T_{<TSD>}$ , the device will switch off the LEDs, and set the  $<TSD>$  flag in the status register.  $<TSD>$  and  $<TW>$  flags represent an event has happened and may not represent the current state of the IC. After the  $<TSD>$  flag is set, the device can only enter normal operation again after it is cooled down below the  $T_{<TW>}$  level. After a  $<TSD>$  occurrence and the cooling down period, the NCV7430 will resume normal operation.

**Thermal Control Bit**

When the thermal control bit  $<TH\_CONT>$  is set, the NCV7430 will actively regulate the LED currents as programmed by the user when exceeding a thermal warning threshold. This function protects the device and the LEDs from overheating without interaction from the LIN master. When  $T_{<TW>}$  is reached, the NCV7430 will decrease the LED currents by a step defined by the parameter  $TH\_Ired\_step$ . The reduction in current is represented by the status bit  $<TH\_CONT\_STATE>$ . If after  $t_{TH\_timeout}$  seconds the thermal warning condition is still present, the current is decreased further. If the thermal warning condition is removed within the  $t_{TH\_timeout}$  seconds, the NCV7430 keeps the reduced current setting for the next  $t_{TH\_timeout}$

period. The reduced current state is presented by the 4 bit <TH\_CONT\_STATE[3:0]> register.

Under normal conditions the Thermal Warning level has the value as specified by  $T_{TW}$ . With the OTP programmable bit <TWPROG>, the Thermal warning and Thermal Shutdown levels can be reduced by 20°C.

The currents can be set back to their normal operating values by writing the <LEDs ON/OFF> bit to '1' in the control register where the bit was previously set. After this command the <TH\_CONT\_STATE > is reset to '0'.

Note: During thermal control the device is still protected for over temperatures at the Thermal Shutdown threshold.

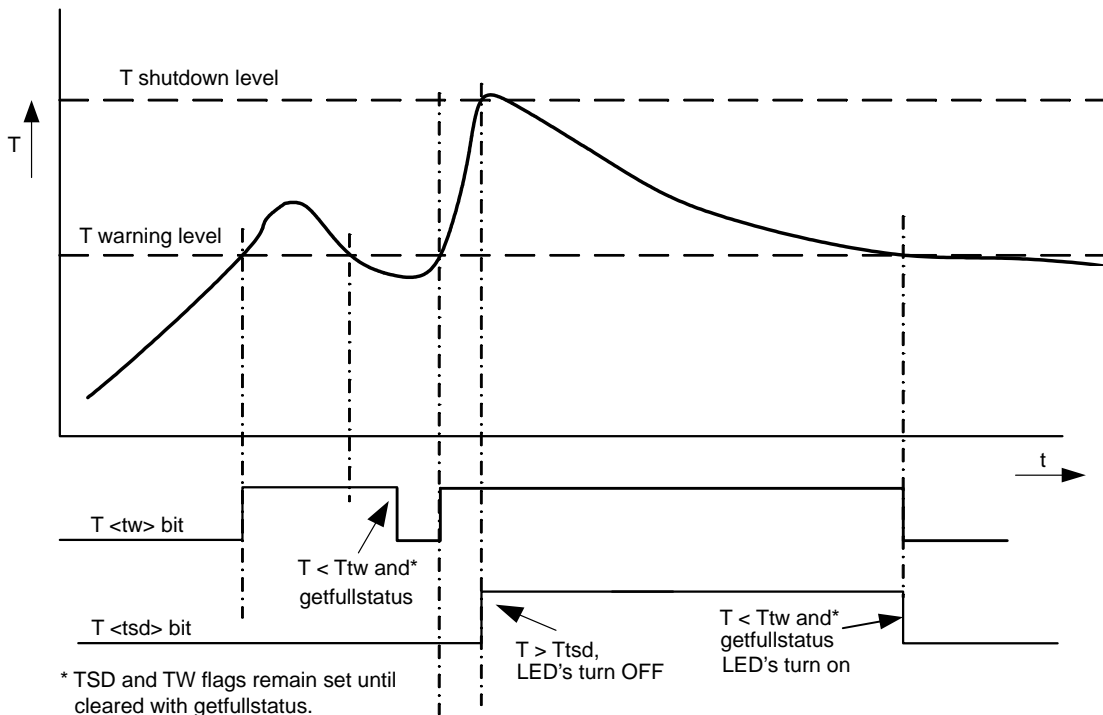

Figure 8. Thermal Management

**Retry Mode**

A retry mode will be entered upon error detection (as per Table 12). Information on this event is stored in the status register (bit <RETRYSTATE>).

After entering the retry mode, the device will switch ON the LED(s) after  $t_{retryinterval}$ . If the error(s) still exists, the device will switch OFF the LEDs. The retry actions are taken place  $N_{numberofretries}$  times. After the last retry, the device will switch OFF the LEDs until a turn-on signal is reinitiated by the user via the LIN pin. This is done by resetting the internal retry counter by reading the Status Register via a GetFullStatus command. After reading, the <RETRYSTATE> and error flags are cleared.

The error conditions “Shorted LED” and “Open circuit” do not switch OFF the LEDs. For these errors, the device relies on the (always active) thermal shutdown and thermal control. When the thermal shutdown temperature threshold is reached, the device will switch OFF the LEDs (reference <ERROFF> below). When thermal control is activated, the

LED currents will be regulated as described in “Thermal warning and thermal control”.

NOTE: *Care has to be taken not to overstress the system by switching on the LEDs repeatedly after detection of errors.*

The <ERROFF> bit residing in OTP can program to act on all LEDs when an error occurs or to act only on the LED(s) that is (are) failing.

NOTE: *The NCV7430 utilizes a single timeout counter for the Retry Interval time. Additional errors occurring after the 1<sup>st</sup> error detection will cause the timer to be reset. This results in an extended retry interval time for the initial detected error. This is highlighted in Figure 9. The device attempts to turn on 20 times (after a GetFullStatus request).*

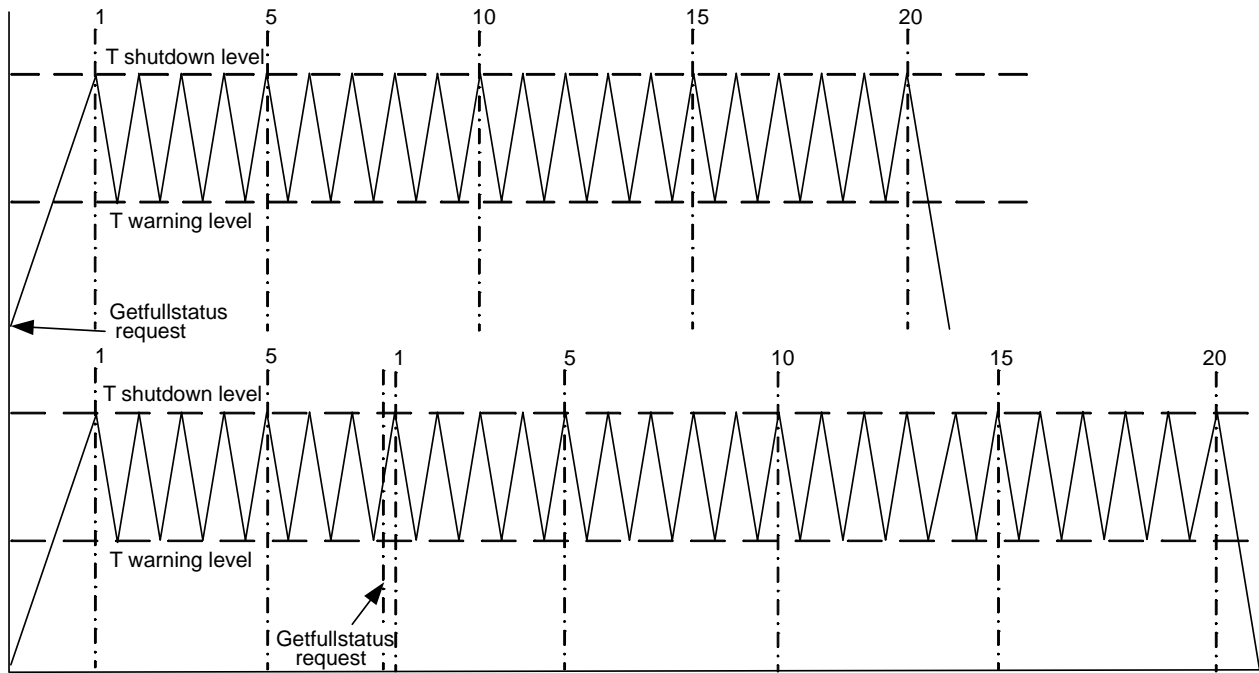

Figure 9. Retry Counter

**Sleep Mode**

In sleep mode, LEDs are turned OFF and the VBIAS output is brought to 0V, turning OFF the optional bypass transistor. The internal circuitry of the NCV7430, including the band gap reference, internal oscillator and current sources are put in low power mode and the internal registers are reset. In Sleep mode the total battery current consumption is reduced to  $I_{bat\_sleep}$  as specified in the DC parameter table. The NCV7430 wakes up from sleep after

detection of a transition of LIN recessive state to dominant state followed by a dominant level for a time period  $>t_{LIN\_Wake}$ .

Refer to Figure 6 for wake time and voltage threshold definitions to wake up via LIN bus transitions.

As per the LIN protocol, a special master request frame is issued to force slave nodes to sleep mode. Reference Table 29 for details of the command structure.

OTP REGISTERS

Table 8. OTP MEMORY STRUCTURE

Address	Bit 7	Bit 6	Bit 5	Bit 4	Bit 3	Bit 2	Bit 1	Bit 0
0x00	OSC4	OSC3	OSC2	OSC1	OSC0	ZAP2	ZAP1	ZAP0
0x01	TSD3	TSD2	TSD1	TSD0	BG3	BG2	BG1	BG0
0x02	DEFAULT	ERROFF	TWPROG	LOCKBT0	PPOL3	PPOPL2	PPOL1	PPOL0
0x03	LOCKBT1	CMDSOFF	AD5	AD4	AD3	AD2	AD1	AD0
0x04	LED modulation Calibration data a11							
0x05	LED modulation Calibration data a12							
0x06	LED modulation Calibration data a13							
0x07	LED modulation Calibration data a21							
0x08	LED modulation Calibration data a22							
0x09	0	1	reserved			TWPROG2	LOW BAUD	BALLAST
0x0A	LED modulation Calibration data a23							
0x0B	LED modulation Calibration data a31							
0x0C	LED modulation Calibration data a32							
0x0D	LED modulation Calibration data a33							
0x0E	LOCKBT2	LED_MOD_FREQ	1	TH_CONT	GROUP_ID3	GROUP_ID2	GROUP_ID1	GROUP_ID0

Table 9. OTP PROGRAMMING BIT DESCRIPTION

Programming Bit	Description
DEFAULT	'1' Enables the LEDs on power-up.
ERROFF	'1' Turns off all LEDs during LEDxC short to ground.
TWPROG, TWPROG2	(See table below)
LOCKBT1	'1' Locks bits per Table 13.
CMDSOFF	'1' Limits command recognition to Set_Color_Short and Set_Intensity.
AD0 – AD5	NCV7430 address programming bits.
LOW BAUD	Expected Low Baud Rate '0' = 9600 BAUD '1' = 10400 BAUD
BALLAST	This bit must be zapped ('1') when using an external ballast transistor. An unzapped bit with the use of a ballast transistor could result in LEDxC short to ground errors.
LOCKBT2	'1' Locks bits per Table 13.
LED_MOD_FREQ	'0' LED modulation frequency – 122 Hz '1' LED modulation frequency – 244 Hz
TH_CONT	'1' Thermal Control Enabled.
GROUP_ID0–GROUP_ID3	NCV7430 group programming bits. 16 possible groups.

Thermal Warning Temperature Select		
TWPROG2	TWPROG	Temperature
0	1	95°C
0	0	115°C
1	1	120°C
1	0	130°C

Table 10. OTP OVERWRITE PROTECTION

Lock Bit	Protected Bytes
LOCKBT0 (factory zapped before delivery)	0x00 – All bits 0x01 – All bits 0x02 – bit 0 to bit 5
LOCKBT1	0x03 0x0E – GROUP_IDx bits
LOCKBT2	0x04 to 0x0D 0x02 – DEFAULT, ERROFF, TWPROG, and TWPROG2 0x03 – CMDSOFF 0x0E – LED_MOD_FREQ and TH_CONT

Parameters stored at address 0x00 and 0x01, and bit 0 to bit 4 of address 0x02 are pre-programmed in the OTP memory at the factory. They correspond to the calibration of the circuit. This does not correspond to LED calibration.

Each OTP bit is set to '0' prior to zapping. Zapping a bit will set it to '1'. Zapping of a bit already at '1' will have no effect.

Each OTP byte needs to be programmed separately (see command SetOTPparam). Once OTP programming is completed, bit <LOCKBT1> and <LOCKBT2> can be zapped to disable future zapping.

After programming the OTP, the contents only become active after a power-on reset. The power-on reset copies the OTP information to the registers.

Table 11. REGISTERS AND FLAGS

Register	Mnemonic	Length (bit)	Related Commands	Comment	Reset State
LED color value LED1	Led 1'	8	<a href="#">Get_Color</a> <a href="#">Set_Color</a> <a href="#">Set_Color_Short</a> <a href="#">Get_Actual_param</a>	8-bit unsigned: 0x00 .. 0xFF	"00"
LED color value LED2	Led 2'	8	<a href="#">Get_Color</a> <a href="#">Set_Color</a> <a href="#">Set_Color_Short</a> <a href="#">Get_Actual_param</a>	8-bit unsigned: 0x00 .. 0xFF	"00"
LED color value LED3	Led 3'	8	<a href="#">Get_Color</a> <a href="#">Set_Color</a> <a href="#">Set_Color_Short</a> <a href="#">Get_Actual_param</a>	8-bit unsigned: 0x00 .. 0xFF	"00"
LED modulation Calibration a11	Cal_a11	8	<a href="#">Get_Actual_Param</a> <a href="#">Set_Primary_Cal_Param</a>	8-bit unsigned: 0x00 .. 0xFF	From OTP or "FF" when all OTP values are "0"
LED modulation Calibration a22	Cal_a22	8	<a href="#">Get_Actual_Params</a> <a href="#">Set_Primary_Cal_Param</a>	8-bit unsigned: 0x00 .. 0xFF	From OTP or "FF" when all OTP values are "0"
LED modulation Calibration a33	Cal_a33	8	<a href="#">Get_Actual_Param</a> <a href="#">Set_Primary_Cal_Param</a>	8-bit unsigned: 0x00 .. 0xFF	From OTP or "FF" when all OTP values are "0"
LED modulation Calibration a12	Cal_a12	8	<a href="#">Get_Actual_Param</a> <a href="#">Set_Secondary_Cal_Param</a>	8-bit unsigned: 0x00 .. 0xFF	FROM OTP
LED modulation Calibration a13	Cal_a13	8	<a href="#">Get_Actual_Param</a> <a href="#">Set_Secondary_Cal_Param</a>	8-bit unsigned: 0x00 .. 0xFF	FROM OTP
LED modulation Calibration a21	Cal_a21	8	<a href="#">Get_Actual_Param</a> <a href="#">Set_Secondary_Cal_Param</a>	8-bit unsigned: 0x00 .. 0xFF	FROM OTP
LED modulation Calibration a23	Cal_a23	8	<a href="#">Get_Actual_Param</a> <a href="#">Set_Secondary_Cal_Param</a>	8-bit unsigned: 0x00 .. 0xFF	FROM OTP
LED modulation Calibration a31	Cal_a31	8	<a href="#">Get_Actual_Param</a> <a href="#">Set_Secondary_Cal_Param</a>	8-bit unsigned: 0x00 .. 0xFF	FROM OTP
LED modulation Calibration a32	Cal_a32	8	<a href="#">Get_Actual_Param</a> <a href="#">Set_Secondary_Cal_Param</a>	8-bit unsigned: 0x00 .. 0xFF	FROM OTP
Calibration Enable	CAL_EN	1	<a href="#">Get_LED_Control</a> <a href="#">Set_LED_Control</a> <a href="#">Get_Actual_Param</a>	"0": Calibration is not used "1": Calibration is used	"1"
Ambient light intensity	AMBLIGHT INTENSITY	4	<a href="#">Set_Intensity</a>	4 bit linear scaling for intensity	"15"
Fading Time	Fading time[5:0]	6	<a href="#">Set_Color</a> <a href="#">Get_Actual_Param</a>	6-bit unsigned: 0 .. 6.3 seconds in resolution steps of 0.1 secs	"00"
Fading ON/OFF	FADING ON/OFF	1	<a href="#">Set_Color</a> <a href="#">Get_Actual_Param</a>	"0" : Fading off "1" : Fading on	If DEFAULT = 1: "1" If DEFAULT = 0: "0"
Fading Slope	FADING SLOPE	1	<a href="#">Set_Color</a> <a href="#">Get_Actual_Param</a>	"0" : Fading slope logarithmic "1" : Fading slope Linear	"0"
Thermal Control	TH_CONT	1	<a href="#">Set_LED_Control</a> <a href="#">Get_Actual_Param</a> <a href="#">Get_LED_Control</a>	"0" : Automatic thermal control Disabled "1" : Automatic thermal control Enabled	FROM OTP
DEFAULT state after power-on	DEFAULT	1	<a href="#">Set_OTP_Param</a>	"0" : Default power-up state: LEDs and Fading OFF "1" : Default power-up state: LEDs and Fading ON	FROM OTP
LED error detection selection	ERROFF	1	<a href="#">Set_OTP_Param</a>	"0" : Only failing LED off when an error is detected "1" : All LEDs off when an error is detected	FROM OTP
Commands OFF	CMDSOFF	1	<a href="#">Set_OTP_Param</a>	"0" : All LIN commands are validated and executed "1" : Only LIN command Set_Color_Short and Set_intensity are validated and executed, all other command are disabled for use.	FROM OTP

Table 11. REGISTERS AND FLAGS

Register	Mnemonic	Length (bit)	Related Commands	Comment	Reset State
Thermal Control Status	TH_CONT_STATE[3:0]	4	<a href="#">Get_Full_Status</a>	4 bits unsigned "0" : current reduced to 6.25% DC "15" : current not reduced (Max ON DC)	"15"
TWPROG	TWPROG	1	<a href="#">Set_OTP_Param</a>	"0" "1" Works with TWPROG2 Thermal Warning Level Set per the Temperature Select Table.	FROM OTP
TWPROG2	TWPROG2	1	<a href="#">Set_OTP_Param</a>	"0" "1" Works with TWPROG Thermal Warning Level Set per the Temperature Select Table.	FROM OTP
LEDs ON/OFF	LEDs ON/OFF	1	<a href="#">Set_LED_Control</a> <a href="#">Set_Color</a> <a href="#">Get_LED_Control</a>	"0" : All LEDs OFF "1" : All LEDs ON if individual LEDx ENABLE is set to "1"	If DEFAULT = 1: "1" If DEFAULT = 0: "0"
LED1 ENABLE	LED1 ENABLE	1	<a href="#">Set_LED_Control</a> <a href="#">Get_LED_Control</a>	"0" : LED 1 OFF "1" : LED 1 ON	If DEFAULT = 1: "1" If DEFAULT = 0: "0"
LED2 ENABLE	LED2 ENABLE	1	<a href="#">Set_LED_Control</a> <a href="#">Get_LED_Control</a>	"0" : LED 2 OFF "1" : LED 2 ON	If DEFAULT = 1: "1" If DEFAULT = 0: "0"
LED3 ENABLE	LED3 ENABLE	1	<a href="#">Set_LED_Control</a> <a href="#">Get_LED_Control</a>	"0" : LED 3 OFF "1" : LED 3 ON	If DEFAULT = 1: "1" If DEFAULT = 0: "0"
UPDATECOLOR mode	UPDATE_COLOR[1:0]	2	<a href="#">Set_Color</a>	"00": immediate update "01": store and do not update "10": update to the already stored values "11": discard	"0"
RETRY state	RETRYSTATE	1	<a href="#">Get_Full_Status</a> <a href="#">Get_Status</a>	"0": not in retry state "1": device is retrying to recover from error	"0"
LED modulation frequency	LED_MOD_FREQ	1	<a href="#">Set_LED_Control</a> <a href="#">Get_Actual_Param</a> <a href="#">Get_LED_Control</a>	"0" : 122 Hz "1" : 244 Hz	FROM OTP
ERROR LED 1	ERRLED1[2:0]	3	<a href="#">Get_Full_Status</a> <a href="#">GetStatus</a>	Refer to Table 8	"x"
ERROR LED 2	ERRLED2[2:0]	3	<a href="#">Get_Full_Status</a> <a href="#">GetStatus</a>	Refer to Table 8	"x"
ERROR LED 3	ERRLED3[2:0]	3	<a href="#">Get_Full_Status</a> <a href="#">GetStatus</a>	Refer to Table 8	"x"
Thermal warning	TW	1	<a href="#">Get_Full_Status</a> <a href="#">GetStatus</a>	Thermal warning detected	"x"
Thermal Shutdown	TSD	1	<a href="#">Get_Full_Status</a> <a href="#">GetStatus</a>	Thermal Shutdown detected	"x"
Tinfo	Tinfo[1:0]	2	<a href="#">Get_Full_Status</a>	00: $T < T_{<TW>}$ 01: $T_{<TW>} < T < T_{<TSD>}$ 11: $T > T_{<TSD>}$	"x"
VBB_reset	VBB_Reset	1	<a href="#">Get_Full_Status</a>	POR reset detected	"1"
LIN Data Error	LIN Data Error	1	<a href="#">Get_Full_Status</a>	Checksum Error + Stopbit Error + Length Error	"x"
LIN Header Error	LIN Header Error	1	<a href="#">Get_Full_Status</a>	Parity Error + Synch field Error	"x"
LIN Bit Error	LIN Bit Error	1	<a href="#">Get_Full_Status</a>	Difference in sent and monitored bit	"x"

LIN CONTROLLER

General Description

The LIN (local interconnect network) is a serial communications protocol that efficiently supports the control of distributed nodes in automotive applications. The physical interface implemented in the NCV7430 is compliant to the LIN rev. 2.0 & 2.1 specifications. It features a slave node, thus allowing for:

- single-master / multiple-slave communication
- self synchronization without quartz or ceramics resonator in the slave nodes
- guaranteed latency times for signal transmission
- single-signal-wire communication
- transmission speed of 19.2 kbit/s, 10.4 kbit/s and 9.6 kbit/s
- selectable length of Message Frame: 2, 4, and 8 bytes
- configuration flexibility
- data checksum (classic checksum) security and error detection
- detection of defective nodes in the network

It includes the analog physical layer and the digital protocol handler.

The analog circuitry implements a low side driver with a pull-up resistor as a transmitter, and a resistive divider with a comparator as a receiver. The specification of the line driver/receiver follows the ISO 9141 standard with some enhancements regarding the EMI behavior.

Slave Operational Range for Proper Self Synchronization

The LIN interface will synchronize properly in the following conditions:

- Vbat: sufficiently high
- Ground shift between master node and slave node < ±1 V

It is highly recommended to use the same type of reverse battery voltage protection diode for the Master and the Slave nodes.

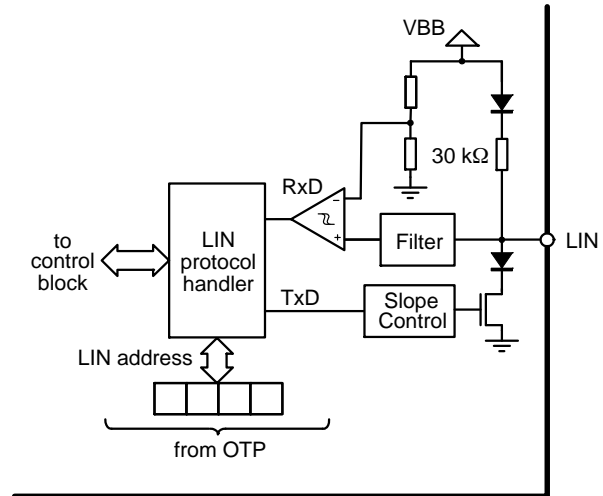

Figure 10.

Functional Description

Analog Part

The transmitter is a low-side driver with a pull-up resistor and slope control. The receiver mainly consists of a comparator with a threshold equal to  $V_{BB}/2$ . Figure 5 shows the characteristics of the transmitted and received signal. See [AC Parameters](#) for timing values.

Protocol Handler

This block implements:

- Bit synchronization
- Bit timing
- The MAC layer
- The LLC layer
- The supervisor

Error Status Register

The LIN interface implements a register containing an error status of the LIN communication. This register is as follows:

Table 12. LIN ERROR REGISTER

Bit 7	Bit 6	Bit 5	Bit 4	Bit 3	Bit 2	Bit 1	Bit 0
Not used	Not used	Not used	Not used	Not used	Data error Flag	Header error Flag	Bit error Flag

With:

Data error flag: (= Checksum error + StopBit error + Length error)

Header error flag: (= Parity error + SynchField error)

Bit error flag: Difference in bit sent and bit monitored on the LIN bus

A [GetFullStatus](#) frame will reset the LIN error status register.

**Physical Address of the Circuit**

The circuit must be provided with a node address in order to discriminate this circuit from other ones on the LIN bus. This address is coded on 6 bits, yielding the theoretical possibility of 64 different devices on the same (logical) bus. However the maximum number of nodes in a LIN network is also limited by the physical properties of the bus line.

Beside the node address a 4 bit “GROUP\_ID” identifier is available. This “GROUP\_ID” identifier is only evaluated when the Broad bit is recognized as ‘0’. The “GROUP\_ID” identifier assigns the node to one of 16 groups. The node can only be assigned to one group. The LIN message will use 16 bit locations for the Groups. When the Node “GROUP\_ID” identifier matches the bit in the message, the message will be evaluated. Refer to Figure 8.

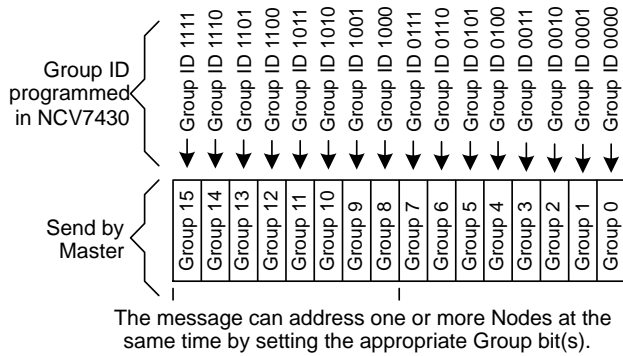

**Figure 11.**

Resuming: The NCV7430 is individually addressable by its LIN node address and cluster addressable via the “Group” bits when ‘Broad’ is ‘0’.

**NOTE:** For the *Set\_Color\_Short* and *Set\_Intensity* commands the *GROUP\_ID* bits are split. The lower two bits are used to assign the NCV7430 to one of four groups for the color setting, while the upper two bits are used to assign the device to one of four groups for the intensity setting.

**BAUD Rate**

The NCV7430 device automatically distinguishes between high and low baud rates.

A high baud rate of 19200 transmitted by the master will be duplicated by the slave.

There are two low baud rates in use between the US and Europe. They are 9600 and 10400. To eliminate possible confusion between these two closely related frequencies, the device is programmable via the OTP register to select between the two frequencies (reference Table 8).

**LIN Frames**

The LIN frames can be divided in writing and reading frames. A frame is composed of an 8-bit Identifier followed by 2, 4 or 8 data-bytes and a checksum byte.

**NOTE:** The checksum conforms to LIN 1.3. This means that all identifiers are validated with classic checksum.

Writing frames will be used to:

- Program the OTP Memory;
- Configure the LED parameters (Modulation value etc);
- Control of the LED Outputs.

Whereas reading frames will be used to:

- Get status information such as error flags;
- Reading OTP for calibration by MCU;
- Verify the right programming and configuration of the component.

**Writing Frames**

The LIN master sends commands and/or information to the slave nodes by means of a writing frame. According to the LIN specification, identifiers are to be used to determine a specific action. If a physical addressing is needed, then some bits of the data field can be dedicated to this, as illustrated in the example below.

Identifier Byte								Data Byte 1				Data Byte 2			
ID 0	ID 1	ID 2	ID 3	ID 4	ID 5	ID 6	ID 7								
								phys. address				command parameters (e.g. position)			

<ID6> and <ID7> are used for parity check over <ID0> to <ID5>, conforming to LIN2.1 specification. <ID6> = <ID0> ⊕ <ID1> ⊕ <ID2> ⊕ <ID4> (even parity) and <ID7> = NOT(<ID1> ⊕ <ID3> ⊕ <ID4> ⊕ <ID5>) (odd parity).

## NCV7430

Another possibility is to determine the specific action within the data field in order to use fewer identifiers. One can for example use the reserved identifier 0x3C and take advantage of the 8 byte data field to provide a physical address, a command and the needed parameters for the action, as illustrated in the example below.

ID		Data Byte 1	Data Byte 2	Data Byte 3	Data Byte 4	Data Byte 5	Data Byte 6	Data Byte 7	Data Byte 8
0x3C	00		1						
		AppCmd	command	physical address	parameters				

NOTE: Bit 7 of Data byte 1 must be at '1' since the LIN specification requires that contents from 0x00 to 0x7F must be reserved for broadcast messages (0x00 being for the "Sleep" message). See also LIN command [Sleep](#). The NCV7430 is using both of above mentioned methods.

### LIN Commands:

In the following paragraphs all LIN frame commands are described. The gray filled cells of the tables present the bytes sent by the master while the white cells present the bytes sent by the slave (NCV7430).

**Table 13. COMMAND SUMMARY**

Command	Response
Get_Full_Status	Get_Full_Status In frame response 1
Get_Actual_Param1	Get_Actual_Param In frame response 1
Get_Actual_Param2	Get_Actual_Param In frame response 2
Get_OTP_Param 1	Get_OTP_Param In frame response 1
Get_OTP_Param 2	Get_OTP_Param In frame response 2
Get_Status READING FRAME	Get_Status In frame response 1
Get_Color READING FRAME	Get_Color In frame response 1
Get_LED_Control READING FRAME	Get_LED In frame response 1
Set_LED_Control WRITING FRAME	-
Set_Color WRITING FRAME	-
Set_Color_Short	-
Set_Intensity	-
Set_Primary_Cal_Param	-
Set_Secondary_Cal_Param	-
Set_OTP_Param	-
Sleep	-

# NCV7430

## Get\_Full\_Status

This command is provided to the circuit by the LIN master to get a complete status of the circuit. Refer to Registers and Flags Table to see the meaning of the parameters sent to the LIN master.

Note: A Get\_Full\_Status command will clear flags <TW>, <TSD>, <ERRLEDx[2:0]>, <VBB\_Reset> and <RETRYSTATE>. If the error condition persists, the value will be set again.

Get\_Full\_Status conforms to a 0x3C command structure.

**Table 14. Get\_Full\_Status**

Byte	Content	Structure							
		Bit 7	Bit 6	Bit 5	Bit 4	Bit 3	Bit 2	Bit 1	Bit 0
0	Identifier	0	0	1	1	1	1	0	0
1	Data 1	AppCMD = 0x80							
2	Data 2	1	CMD[6:0] = 0x01						
3	Data 3	1	1	AD[5:0]					
4	Data 4	0xFF							
5	Data 5	0xFF							
6	Data 6	0xFF							
7	Data 7	0xFF							
8	Data 8	0xFF							
9	Checksum	Classic Checksum over data							

Get_Full_Status In frame response 1									
Byte	Content	Structure							
		Bit 7	Bit 6	Bit 5	Bit 4	Bit 3	Bit 2	Bit 1	Bit 0
0	Identifier	0	1	1	1	1	1	0	1
1	Data 1	1	1	AD[5:0]					
2	Data 2	0xFF							
3	Data 3	1	1	1	1	1	LIN Data error	LIN Header error	LIN Bit error
4	Data 4	1	1	VBB Under Voltage	VBB Reset	TSD	TW	Tinfo[1:0]	
5	Data 5	TH_CONT STATE 3	TH_CONT STATE 2	TH_CONT STATE 1	TH_CONT STATE 0	RETRY STATE	ERR[2] LED1	ERR[1] LED1	ERR[0] LED1
6	Data 6	1	ERR[2] LED3	ERR[1] LED3	ERR[0] LED3	1	ERR[2] LED2	ERR[1] LED2	ERR[0] LED2
7	Data 7	LED3 ENABLE	LED2 ENABLE	LED1 ENABLE	LEDs ON/OFF	GROUP_ID3	GROUP_ID2	GROUP_ID1	GROUP_ID0
8	Data 8	0xFF							
9	Checksum	Classic Checksum over data							

### Where:

Tinfo[1:0] gives the actual state of the temperature, while TW and TSD present the Latched status

The Error states are as follows:

Error Description:	ERR[2] LEDx	ERR[1] LEDx	ERR[0] LEDx
No Error	0	0	0
Open circuit – LEDxR, Short from ANODE to LEDxC	0	1	1
Open circuit – LEDxC to ANODE	1	0	1
Short from LEDxC to Ground	0	1	0

## NCV7430

The TH\_CONT\_STATE[3:0] read only bits represent the degree of current reduction when the thermal control bit <TH\_CONT> is set .

TH_CONT_STATE[3:0]	Current in % of Nominal
15	Max ON
14	93.75
13	87.50
12	81.25
11	75.00
10	68.75
9	62.50
8	56.25
7	50.00
6	43.75
5	37.50
4	31.25
3	25.00
2	18.75
1	12.50
0	6.25

# NCV7430

## Get\_Actual\_Param

Reads the full set of the actual parameters of the NCV7430. For this command two messages are needed. This is a 0x3C command requiring an in frame slave responses.

**Table 15. Get\_Actual\_Param1**

Byte	Content	Structure							
		Bit 7	Bit 6	Bit 5	Bit 4	Bit 3	Bit 2	Bit 1	Bit 0
0	Identifier	0	0	1	1	1	1	0	0
1	Data 1	AppCMD =0x80							
2	Data 2	1	CMD[6:0] = 0x02						
3	Data 3	1	1	AD[5:0]					
4	Data 4	0xFF							
5	Data 5	0xFF							
6	Data 6	0xFF							
7	Data 7	0xFF							
8	Data 8	0xFF							
9	Checksum	Classic Checksum over data							
<b>Get_Actual_Param In frame response 1</b>									
Byte	Content	Structure							
		Bit 7	Bit 6	Bit 5	Bit 4	Bit 3	Bit 2	Bit 1	Bit 0
0	Identifier	0	1	1	1	1	1	0	1
1	Data 1	1	1	AD[5:0]					
2	Data 2	LED color value LED 1 [7:0]							
3	Data 3	LED color value LED 2 [7:0]							
4	Data 4	LED color value LED 3 [7:0]							
5	Data 5	LED modulation Calibration data a11[7:0]							
6	Data 6	LED modulation Calibration data a22[7:0]							
7	Data 7	LED modulation Calibration data a33[7:0]							
8	Data 8	FADING ON/OFF	FADING SLOPE	Fading time [5:0]					
9	Checksum	Classic Checksum over data							

# NCV7430

**Table 16. Get\_Actual\_Param2**

Byte	Content	Structure							
		Bit 7	Bit 6	Bit 5	Bit 4	Bit 3	Bit 2	Bit 1	Bit 0
0	Identifier	0	0	1	1	1	1	0	0
1	Data 1	AppCMD =0x80							
2	Data 2	1	CMD[6:0] = 0x03						
3	Data 3	1	1	AD[5:0]					
4	Data 4	0xFF							
5	Data 5	0xFF							
6	Data 6	0xFF							
7	Data 7	0xFF							
8	Data 8	0xFF							
9	Checksum	Classic Checksum over data							
<b>Get_Actual_Param In frame response 2</b>									
Byte	Content	Structure							
		Bit 7	Bit 6	Bit 5	Bit 4	Bit 3	Bit 2	Bit 1	Bit 0
0	Identifier	0	1	1	1	1	1	0	1
1	Data 1	1	1	AD[5:0]					
2	Data 2	LED modulation Calibration value a12[7:0]							
3	Data 3	LED modulation Calibration value a13[7:0]							
4	Data 4	LED modulation Calibration value a21[7:0]							
5	Data 5	LED modulation Calibration value a23[7:0]							
6	Data 6	LED modulation Calibration value a31[7:0]							
7	Data 7	LED modulation Calibration value a32[7:0]							
8	Data 8	CAL_EN	LED_MOD_FREQ	1	TH CONT	GROUP_ID3	GROUP_ID2	GROUP_ID1	GROUP_ID0
9	Checksum	Classic Checksum over data							

# NCV7430

## Get\_OTP\_Param

Reads the full set of OTP settings of the NCV7430. For this command two messages are needed. This is a 0x3C command requiring an in frame slave response.

**Table 17. Get\_OTP\_Param 1**

Byte	Content	Structure							
		Bit 7	Bit 6	Bit 5	Bit 4	Bit 3	Bit 2	Bit 1	Bit 0
0	Identifier	0	0	1	1	1	1	0	0
1	Data 1	AppCMD =0x80							
2	Data 2	1	CMD[6:0] = 0x04						
3	Data 3	1	1	AD[5:0]					
4	Data 4	0xFF							
5	Data 5	0xFF							
6	Data 6	0xFF							
7	Data 7	0xFF							
8	Data 8	0xFF							
9	Checksum	Classic Checksum over data							

**Get\_OTP\_Param In frame response 1**

Byte	Content	Structure							
		Bit 7	Bit 6	Bit 5	Bit 4	Bit 3	Bit 2	Bit 1	Bit 0
0	Identifier	0	1	1	1	1	1	0	1
1	Data 1	1	1	AD[5:0]					
2	Data 2	1	1	1	1	1	1	LOW BAUD	DIAGALLOFF
3	Data 3	1	1	1	1	1	1	1	1
4	Data 4	DEFAULT	ERROFF	TWPROG	1	1	1	1	1
5	Data 5	LOCKBT1	CMDSOFF	AD5	AD4	AD3	AD2	AD1	AD0
6	Data 6	LED modulation Calibration data a11[7:0]							
7	Data 7	LED modulation Calibration data a12[7:0]							
8	Data 8	LED modulation Calibration data a13[7:0]							
9	Checksum	Classic Checksum over data							

NOTE: After programming bit <CMDSOFF> all the LIN commands (except Set\_Color\_Short and Set\_intensity) are disabled (The commands are not evaluated and interpreted by the NCV7430).

# NCV7430

**Table 18. Get\_OTP\_Param 2**

Byte	Content	Structure							
		Bit 7	Bit 6	Bit 5	Bit 4	Bit 3	Bit 2	Bit 1	Bit 0
0	Identifier	0	0	1	1	1	1	0	0
1	Data 1	AppCMD =0x80							
2	Data 2	1	CMD[6:0] = 0x05						
3	Data 3	1	1	AD[5:0]					
4	Data 4	0xFF							
5	Data 5	0xFF							
6	Data 6	0xFF							
7	Data 7	0xFF							
8	Data 8	0xFF							
9	Checksum	Classic Checksum over data							
<b>Get_OTP_Param In frame response 2</b>									
Byte	Content	Structure							
		Bit 7	Bit 6	Bit 5	Bit 4	Bit 3	Bit 2	Bit 1	Bit 0
0	Identifier	0	1	1	1	1	1	0	1
1	Data 1	1	1	AD[5:0]					
2	Data 2	LED modulation Calibration data a21[7:0]							
3	Data 3	LED modulation Calibration data a22[7:0]							
4	Data 4	LED modulation Calibration data a23[7:0]							
5	Data 5	LED modulation Calibration data a31[7:0]							
6	Data 6	LED modulation Calibration data a32[7:0]							
7	Data 7	LED modulation Calibration data a33[7:0]							
8	Data 8	LOCKBT2	LED_MOD_FREQ	1	TH_CO NT	GROUP_ID3	GROUP_ID2	GROUP_ID1	GROUP_ID0
9	Checksum	Classic Checksum over data							

## NCV7430

### Get\_Status

This command delivers a short overview of the device status. It will not attempt to reset the error bits. Resetting error bits requires execution of the Get\_Full\_Status command.

Conform a two byte in frame command structure.

**Table 19. Get\_Status READING FRAME**

Byte	Content	Structure							
		Bit 7	Bit 6	Bit 5	Bit 4	Bit 3	Bit 2	Bit 1	Bit 0
0	Identifier	0	0	1	0	0	0	0	0
1	Data 1	1	1	AD[5:0]					
2	Data 2	8'hFF							
3	Checksum	Classic Checksum over data							
<b>Get_Status In frame response 1</b>									
0	Identifier	0	0	0	1	0	0	0	1
1	Data 1	1	1	AD[5:0]					
2	Data 2	TSD	TW	VBB Under Voltage	RETRY STATE	ERROR LED3	ERRORLED2	ERRORLED1	LIN ERROR
3	Checksum	Classic Checksum over data							

Where:

LIN ERROR = Or function of all LIN Errors

Error LED1 = function ERRLED1[2:0] ≠ 0; refer to Table 8

Error LED2 = function ERRLED2[2:0] ≠ 0; refer to Table 8

Error LED3 = function ERRLED3[2:0] ≠ 0; refer to Table 8

RETRY STATE = NCV7430 is retrying to recover from errors

VBB Undervoltage = “0” at power-on reset. Set to a “1” with VBB Undervoltage. Cleared with a GET\_FULL\_STATUS command.

# NCV7430

## Get\_Color

Gives the real modulation register values (after calibration).  
Conform an eight byte in frame command structure.

**Table 20. Get\_Color READING FRAME**

Byte	Content	Structure							
		Bit 7	Bit 6	Bit 5	Bit 4	Bit 3	Bit 2	Bit 1	Bit 0
0	Identifier	0	0	1	0	0	0	0	0
1	Data 1	1	1	AD[5:0]					
2	Data 2	8'hFF							
3	Checksum	Classic Checksum over data							
<b>Get_Color In frame response 1</b>									
Byte	Content	Structure							
		Bit 7	Bit 6	Bit 5	Bit 4	Bit 3	Bit 2	Bit 1	Bit 0
0	Identifier	1	0	0	1	0	0	1	0
1	Data 1	1	1	AD[5:0]					
2	Data 2	LED modulation value LED 1' [7:0] (real LED modulation register)							
3	Data 3	1	1	1	1	LED modulation overflow LED1	LED modulation value LED 1' [10:8]		
4	Data 4	LED modulation value LED 2' [7:0] (real LED modulation register)							
5	Data 5	1	1	1	1	LED modulation overflow LED2	LED modulation value LED 2' [10:8]		
6	Data 6	LED modulation value LED 3' [7:0] (real LED modulation register)							
7	Data 7	Intensity[3:0]			LED modulation overflow LED3		LED modulation value LED 3' [10:8]		
8	Data 8	FADING ON/OFF	FADING SLOPE	Fading time [5:0]					
9	Checksum	Classic Checksum over data							

**Get\_LED\_Control**

This command reads the control bits conform a two byte in frame command structure.

**Table 21. Get\_LED\_Control READING FRAME**

Byte	Content	Structure								
		Bit 7	Bit 6	Bit 5	Bit 4	Bit 3	Bit 2	Bit 1	Bit 0	
0	Identifier	0	0	1	0	0	0	0	0	
1	Data 1	1	1	AD[5:0]						
2	Data 2	8'hFF								
3	Checksum	Classic Checksum over data								
<b>Get_LED In frame response 1</b>										
Byte	Content	Structure								
		Bit 7	Bit 6	Bit 5	Bit 4	Bit 3	Bit 2	Bit 1	Bit 0	
0	Identifier	0	1	0	1	0	0	0	0	
1	Data 1	1	1	AD[5:0]						
2	Data 2	CAL_EN	LED_MOD_FREQ	LEDs ON/OFF	TH CONT	LED3 ENABLE	LED2 ENABLE	LED1 ENABLE	1	
3	Checksum	Classic Checksum over data								

**Set\_LED\_Control**

This command is the overall control command to switch the LEDs on and off.

**Table 22. Set\_LED\_Control WRITING FRAME**

Byte	Content	Structure								
		Bit 7	Bit 6	Bit 5	Bit 4	Bit 3	Bit 2	Bit 1	Bit 0	
0	Identifier	1	0	1	0	0	0	1	1	
1	Data 1	Broad	1	AD[5:0]						
2	Data 2	Group 7 selected	Group 6 selected	Group 5 selected	Group 4 selected	Group 3 selected	Group 2 selected	Group 1 selected	Group 0 selected	
3	Data 3	Group 15 selected	Group 14 selected	Group 13 selected	Group 12 selected	Group 11 selected	Group 10 selected	Group 9 selected	Group 8 selected	
4	Data 4	CAL_EN	LED_MOD_FREQ	LEDs ON/OFF	TH CONT	LED3 ENABLE	LED2 ENABLE	LED1 ENABLE	1	
5	Checksum	Classic Checksum over data								

Where:

Broad: Broad = '0' means group addressing. One or more groups can be selected by setting the corresponding 'GroupX Selected' bit to '1'. All nodes with GROUP\_ID matching the selected groups will act. AD[5:0] bits are ignored.

Broad = '1' means single node addressing. The target node address is indicated by the AD[5:0] bits. Group selection bits are ignored.

This command is executed immediately.

**Set\_Color**

When CAL\_EN is set to '0', the real value for the color setting is written into the LED modulation register. When CAL\_EN is set to '1' the received 8 bit values are first corrected by the matrix calculation and then applied to the LED modulation registers.

**Table 23. Set\_Color WRITING FRAME**

Byte	Content	Structure									
		Bit 7	Bit 6	Bit 5	Bit 4	Bit 3	Bit 2	Bit 1	Bit 0		
0	Identifier	0	1	1	0	0	1	0	0		
1	Data 1	Broad	1	AD[5:0]							
2	Data 2	Group 7 selected	Group 6 selected	Group 5 selected	Group 4 selected	Group 3 selected	Group 2 selected	Group 1 selected	Group 0 selected		
3	Data 3	Group 15 selected	Group 14 selected	Group 13 selected	Group 12 selected	Group 11 selected	Group 10 selected	Group 9 selected	Group 8 selected		
4	Data 4	UPDATE COLOR[1]	UPDATE COLOR[0]	Fading time[5:0]							
5	Data 5	FADING ON/OFF	FADING* SLOPE	LEDs ON/OFF	1	Intensity[3:0]					
6	Data 6	LED color value LED 1 [7:0]									
7	Data 7	LED color value LED 2 [7:0]									
8	Data 8	LED color value LED 3 [7:0]									
9	Checksum	Classic Checksum over data									

Where:

Broad: Broad = '0' means group addressing. One or more groups can be selected by setting the corresponding 'GroupX Selected' bit to '1'. All nodes with GROUP\_ID matching the selected groups will act. AD[5:0] bits are ignored.

Broad = '1' means single node addressing. The target node address is indicated by the AD[5:0] bits. Group selection bits are ignored.

The update of the LED colors is determined by UPDATECOLOR[1:0]

- 00            immediate update
- 01            store and do not update
- 10            update to the already stored values
- 11            discard

**Set\_Color\_Short**

The Set\_Color\_Short command is used to set the LED colors directly for the four groups that are indicated. This command is short and does not contain all the parameters as used in the Set\_Color command. Only four groups can be approached, so the NCV7430 needs to be programmed as member of one of these groups:

(lowest two bits of GROUP\_ID in OTP; GROUP\_ID0 and GROUP\_ID1; presenting 0 to 3 for color).

NOTE: This command is always acting towards groups. Individual node addresses are not implemented.

**Table 24. Set\_Color\_Short WRITING FRAME**

Byte	Content	Structure							
		Bit 7	Bit 6	Bit 5	Bit 4	Bit 3	Bit 2	Bit 1	Bit 0
0	Identifier	0	1	1	0	1	1	1	1
1	Data 1	LED color value LED 1 [7:0]							
2	Data 2	LED color value LED 2 [7:0]							
3	Data 3	LED color value LED 3 [7:0]							
4	Data 4	1	1	1	1	C_GroupD selected	C_GroupC selected	C_GroupB selected	C_GroupA selected
5	Checksum	Classic Checksum over data							

Where:

Color Groups	Corresponding GROUP_ID Range
C_GroupA	xx00
C_GroupB	xx01
C_GroupC	xx10
C_GroupD	xx11

\*Fading Slope = 0 = logarithmic  
 = 1 = linear

Choose either 0 or 1 when setting control for intensity

Fading Slope must be set to '1' for color control (only Linear is allowed).

**Set\_Intensity**

The Set\_Intensity command is used to set the LED colors directly for the groups that are indicated. Only four groups can be approached, so the NCV7430 needs to be programmed as member of one of these groups:

(higher two bits of GROUP\_ID in OTP; GROUP\_ID2 and GROUP\_ID3; presenting 0 to 3 for intensity).

NOTE: This command is always acting towards groups. Individual node addresses are not implemented.

**Table 25. Set\_Intensity WRITING FRAME**

Byte	Content	Structure							
		Bit 7	Bit 6	Bit 5	Bit 4	Bit 3	Bit 2	Bit 1	Bit 0
0	Identifier	0	0	1	0	1	1	1	0
1	Data 1	I_GroupD selected	I_GroupC selected	I_GroupB selected	I_GroupA selected	Intensity[3:0]			
2	Data 2	1	1	Fading time[5:0]					
3	Checksum	Classic Checksum over data							

Where:

Intensity Groups	Corresponding GROUP_ID Range
I_GroupA	00xx
I_GroupB	01xx
I_GroupC	10xx
I_GroupD	11xx

# NCV7430

## Set\_Primary\_Cal\_Param

Using a four byte command structure. These registers are updated as default from OTP after a power-on reset.

**Table 26. Set\_Primary\_Cal\_Param WRITING FRAME**

Byte	Content	Structure							
		Bit 7	Bit 6	Bit 5	Bit 4	Bit 3	Bit 2	Bit 1	Bit 0
0	Identifier	0	0	1	0	0	1	0	1
1	Data 1	1	1	AD[5:0]					
2	Data 2	LED modulation Calibration value a11[7:0]							
3	Data 3	LED modulation Calibration value a22[7:0]							
4	Data 4	LED modulation Calibration value a33[7:0]							
5	Checksum	Classic Checksum over data							

## Set\_Secondary\_Cal\_Param

Using an eight byte command structure. These registers are updated as default from OTP after a power-on reset.

**Table 27. Set\_Secondary\_Cal\_Param WRITING FRAME**

Byte	Content	Structure							
		Bit 7	Bit 6	Bit 5	Bit 4	Bit 3	Bit 2	Bit 1	Bit 0
0	Identifier	0	1	1	1	0	1	1	0
1	Data 1	1	1	AD[5:0]					
2	Data 2	LED modulation Calibration value a12[7:0]							
3	Data 3	LED modulation Calibration value a13[7:0]							
4	Data 4	LED modulation Calibration value a21[7:0]							
5	Data 5	LED modulation Calibration value a23[7:0]							
6	Data 6	LED modulation Calibration value a31[7:0]							
7	Data 7	LED modulation Calibration value a32[7:0]							
8	Data 8	0xFF							
9	Checksum	Classic Checksum over data							

**Set\_OTP\_Param**

This command is used for programming the individual bytes of the OTP memory. The OTP address is the pointer to the byte in OTP (refer to Table 8 OTP memory structure).

Used is a four byte command structure.

**Table 28. Set\_OTP\_Param WRITING FRAME**

Byte	Content	Structure							
		Bit 7	Bit 6	Bit 5	Bit 4	Bit 3	Bit 2	Bit 1	Bit 0
0	Identifier	1	1	1	0	0	1	1	1
1	Data 1	1	1	AD[5:0]					
2	Data 2	0xFF							
3	Data 3	1	1	1	1	OTP address pointer[3:0]			
4	Data 4	OTP contents [7:0]							
5	Checksum	Classic Checksum over data							

**Sleep**

This command is provided to the circuit by the LIN master to put all the slave nodes connected to the LIN bus into sleep mode. See LIN 2.1 specification and Sleep Mode. The corresponding LIN frame is a master request command frame (identifier **0x3C**) with data byte 1 containing 0x00 while the followings contain 0xFF.

**Table 29. SLEEP WRITING FRAME**

Byte	Content	Structure							
		Bit 7	Bit 6	Bit 5	Bit 4	Bit 3	Bit 2	Bit 1	Bit 0
0	Identifier	0	0	1	1	1	1	0	0
1	Data 1	0x00							
2	Data 2	0xFF							
3	Data 3	0xFF							
4	Data 4	0xFF							
5	Data 5	0xFF							
6	Data 6	0xFF							
7	Data 7	0xFF							
8	Data 8	0xFF							
9	Checksum	Classic Checksum over data							

APPLICATIONS INFORMATION

High Current LEDs

The NCV7430 is designed to drive RGB LEDs up to currents of 30 mA per channel. The system capability can be increased to drive higher current LEDs by configuring the device with an external PNP transistor as shown in Figure 12. In this setup, all the LED current is external to the device. Output current is limited by the base drive to the PNP (30 mA) and the beta of the PNP. Operation is controlled by the external feedback provided by R3 through R2 to the device pin LEDxR.

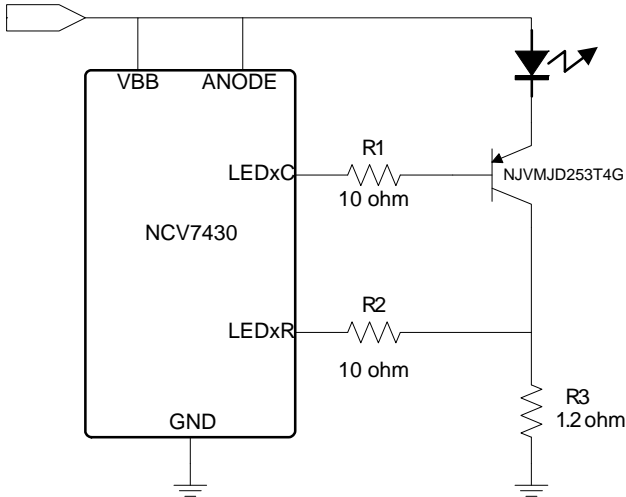

Figure 12. Using the NCV7430 with Higher Current LEDs

Temperature Correction

Light output from LEDs change with temperature. As temperature increases, light output goes down. The magnitude of change typically depends on the type of LEDs which are used. Red LEDs are typically manufactured using AlInGaP while green and blue LEDs are typically manufactured using AlInGaN. These processing differences result in the red LED temperature sensitivity being much more sensitive than the green or blue LEDs. As a result, the green and blue LEDs do not require any corrective adjustments while the red LEDs require the drive current to be increased as temperature goes up to keep a constant light output.

Temperature correction can be implemented using the current programming pin, LED1R by using a programming

network comprised of a resistor in series with a schottky diode in parallel with another resistor as shown in Figure 13.  $R_{redled}$  sets the nominal LED current and the Schottky diode with the series resistor (R1) sets the temperature behavior.

The NCV7430 uses a bandgap referenced circuit for creating the programming reference voltage on the LEDxR pins. The bandgap reference voltage targets to maintain a zero TC voltage.

If the system design is able to correlate the red LED temperature to the NCV7430 IC temperature, there is a potential to create a compensation for these thermal effects. Starting with the zero temperature coefficient reference voltage on the LED1R pin, we can break up the voltage into two components by mandating a negative temperature coefficient associated with one component, and leave a positive temperature coefficient associated with the other component. This is done by adding a schottky diode in series with the programming resistor on the LED1R pin. The negative temperature coefficient of the schottky diode creates an overall positive temperature coefficient on the resistor in series. The system designer should consider the resulting positive voltage temperature coefficient with the discrete resistor temperature coefficient to obtain the desired temperature performance. Note, a schottky diode is required over p-n junction diodes due to the low voltage on the LED1R pin (325 mV [typ]).

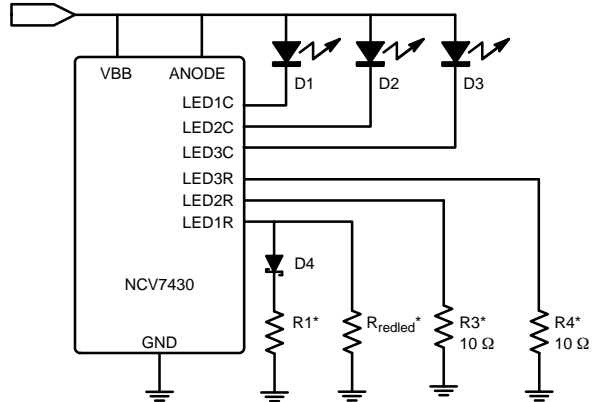
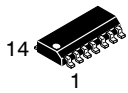

Figure 13. External Temperature Compensation

\*R3, R4 = 10 Ω for 30 mA LED current.  
 R1, R<sub>redled</sub> values dependent on application.  
 R1, D4 set the LED current temperature coefficient.



SCALE 1:1

SOIC-14  
CASE 751AP  
ISSUE B

DATE 18 MAY 2015

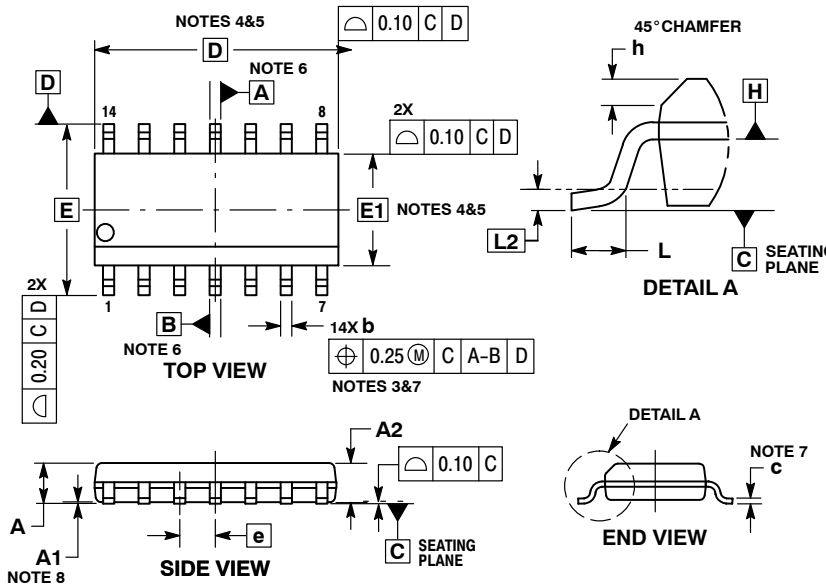

- NOTES:
1. DIMENSIONING AND TOLERANCING PER ASME Y14.5M, 1994.
  2. CONTROLLING DIMENSION: MILLIMETERS.
  3. DIMENSION b DOES NOT INCLUDE DAMBAR PROTRUSION. ALLOWABLE PROTRUSION SHALL BE 0.004 mm IN EXCESS OF MAXIMUM MATERIAL CONDITION.
  4. DIMENSION D DOES NOT INCLUDE MOLD FLASH, PROTRUSIONS OR GATE BURRS. MOLD FLASH, PROTRUSIONS OR GATE BURRS SHALL NOT EXCEED 0.006 mm PER SIDE. DIMENSION E1 DOES NOT INCLUDE INTERLEAD FLASH OR PROTRUSION. INTERLEAD FLASH OR PROTRUSION SHALL NOT EXCEED 0.010 mm PER SIDE.
  5. THE PACKAGE TOP MAY BE SMALLER THAN THE PACKAGE BOTTOM. DIMENSIONS D AND E1 ARE DETERMINED AT THE OUTER-MOST EXTREMES OF THE PLASTIC BODY AT DATUM H.
  6. DIMENSIONS A AND B ARE TO BE DETERMINED AT DATUM H.
  7. DIMENSIONS b AND c APPLY TO THE FLAT SECTION OF THE LEAD BETWEEN 0.10 TO 0.25 FROM THE LEAD TIP.
  8. A1 IS DEFINED AS THE VERTICAL DISTANCE FROM THE SEATING PLANE TO THE LOWEST POINT ON THE PACKAGE BODY.

DIM	MILLIMETERS	
	MIN	MAX
A	---	1.75
A1	0.10	0.25
A2	1.25	---
b	0.31	0.51
c	0.10	0.25
D	8.65 BSC	
E	6.00 BSC	
E1	3.90 BSC	
e	1.27 BSC	
h	0.25	0.41
L	0.40	1.27
L2	0.25 BSC	

RECOMMENDED  
SOLDERING FOOTPRINT\*

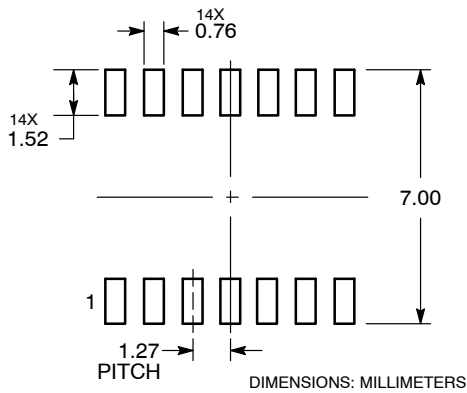

\*For additional information on our Pb-Free strategy and soldering details, please download the onsemi Soldering and Mounting Techniques Reference Manual, SOLDERRM/D.

GENERIC  
MARKING DIAGRAM\*

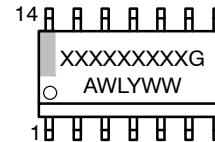

- XXXXX = Specific Device Code
- A = Assembly Location
- WL = Wafer Lot
- Y = Year
- WW = Work Week
- G = Pb-Free Package

\*This information is generic. Please refer to device data sheet for actual part marking. Pb-Free indicator, "G" or microdot "▪", may or may not be present.

DOCUMENT NUMBER:	98AON30871E	Electronic versions are uncontrolled except when accessed directly from the Document Repository. Printed versions are uncontrolled except when stamped "CONTROLLED COPY" in red.
DESCRIPTION:	SOIC-14	PAGE 1 OF 1

onsemi and ONSEMI are trademarks of Semiconductor Components Industries, LLC dba onsemi or its subsidiaries in the United States and/or other countries. onsemi reserves the right to make changes without further notice to any products herein. onsemi makes no warranty, representation or guarantee regarding the suitability of its products for any particular purpose, nor does onsemi assume any liability arising out of the application or use of any product or circuit, and specifically disclaims any and all liability, including without limitation special, consequential or incidental damages. onsemi does not convey any license under its patent rights nor the rights of others.

**onsemi**, **Onsemi**, and other names, marks, and brands are registered and/or common law trademarks of Semiconductor Components Industries, LLC dba "**onsemi**" or its affiliates and/or subsidiaries in the United States and/or other countries. **onsemi** owns the rights to a number of patents, trademarks, copyrights, trade secrets, and other intellectual property. A listing of **onsemi**'s product/patent coverage may be accessed at [www.onsemi.com/site/pdf/Patent-Marking.pdf](http://www.onsemi.com/site/pdf/Patent-Marking.pdf). **onsemi** reserves the right to make changes at any time to any products or information herein, without notice. The information herein is provided "as-is" and **onsemi** makes no warranty, representation or guarantee regarding the accuracy of the information, product features, availability, functionality, or suitability of its products for any particular purpose, nor does **onsemi** assume any liability arising out of the application or use of any product or circuit, and specifically disclaims any and all liability, including without limitation special, consequential or incidental damages. Buyer is responsible for its products and applications using **onsemi** products, including compliance with all laws, regulations and safety requirements or standards, regardless of any support or applications information provided by **onsemi**. "Typical" parameters which may be provided in **onsemi** data sheets and/or specifications can and do vary in different applications and actual performance may vary over time. All operating parameters, including "Typicals" must be validated for each customer application by customer's technical experts. **onsemi** does not convey any license under any of its intellectual property rights nor the rights of others. **onsemi** products are not designed, intended, or authorized for use as a critical component in life support systems or any FDA Class 3 medical devices or medical devices with a same or similar classification in a foreign jurisdiction or any devices intended for implantation in the human body. Should Buyer purchase or use **onsemi** products for any such unintended or unauthorized application, Buyer shall indemnify and hold **onsemi** and its officers, employees, subsidiaries, affiliates, and distributors harmless against all claims, costs, damages, and expenses, and reasonable attorney fees arising out of, directly or indirectly, any claim of personal injury or death associated with such unintended or unauthorized use, even if such claim alleges that **onsemi** was negligent regarding the design or manufacture of the part. **onsemi** is an Equal Opportunity/Affirmative Action Employer. This literature is subject to all applicable copyright laws and is not for resale in any manner.

## ADDITIONAL INFORMATION

### TECHNICAL PUBLICATIONS:

Technical Library: [www.onsemi.com/design/resources/technical-documentation](http://www.onsemi.com/design/resources/technical-documentation)  
onsemi Website: [www.onsemi.com](http://www.onsemi.com)

### ONLINE SUPPORT: [www.onsemi.com/support](http://www.onsemi.com/support)

For additional information, please contact your local Sales Representative at [www.onsemi.com/support/sales](http://www.onsemi.com/support/sales)

# Mouser Electronics

Authorized Distributor

Click to View Pricing, Inventory, Delivery & Lifecycle Information:

[onsemi:](#)

[NCV74300V1GEVK](#) [NCV7430D20R2G](#)