



Single-Supply, High-Speed, Precision LOGARITHMIC AMPLIFIER

FEATURES

- **ADVANTAGES:**
 - Tiny for High Density Systems
 - Precision on One Supply
 - Fast Over Eight Decades
 - Fully-Tested Function
- **TWO SCALING AMPLIFIERS**
- **WIDE INPUT DYNAMIC RANGE:**
Eight Decades, 100pA to 10mA
- **2.5V REFERENCE**
- **STABLE OVER TEMPERATURE**
- **LOW QUIESCENT CURRENT: 10mA**
- **DUAL OR SINGLE SUPPLY: ±5V, +5V**
- **PACKAGE: Small QFN-16 (4mm x 4mm)**
- **SPECIFIED TEMPERATURE RANGE:**
–5°C to +75°C

APPLICATIONS

- **ONET ERBIUM-DOPED FIBER OPTIC AMPLIFIER (EDFA)**
- **LASER OPTICAL DENSITY MEASUREMENT**
- **PHOTODIODE SIGNAL COMPRESSION AMP**
- **LOG, LOG-RATIO FUNCTION**
- **ANALOG SIGNAL COMPRESSION IN FRONT OF ANALOG-TO-DIGITAL (ADC) CONVERTER**
- **ABSORBANCE MEASUREMENT**

DESCRIPTION

The LOG114 is specifically designed for measuring low-level and wide dynamic range currents in communications, lasers, medical, and industrial systems. The device computes the logarithm or log-ratio of an input current or voltage relative to a reference current or voltage (logarithmic transimpedance amplifier).

High precision is ensured over a wide dynamic range of input signals on either bipolar (±5V) or single (+5V) supply. Special temperature drift compensation circuitry is included on-chip. In log-ratio applications, the signal current may be from a high impedance source such as a photodiode or resistor in series with a low impedance voltage source. The reference current is provided by a resistor in series with a precision internal voltage reference, photo diode, or active current source.

The output signal at V_{LOGOUT} has a scale factor of 0.375V out per decade of input current, which limits the output so that it fits within a 5V or 10V range. The output can be scaled and offset with one of the available additional amplifiers, so it matches a wide variety of ADC input ranges. Stable dc performance allows accurate measurement of low-level signals over a wide temperature range. The LOG114 is specified over a –5°C to +75°C temperature range and can operate from –40°C to +85°C.

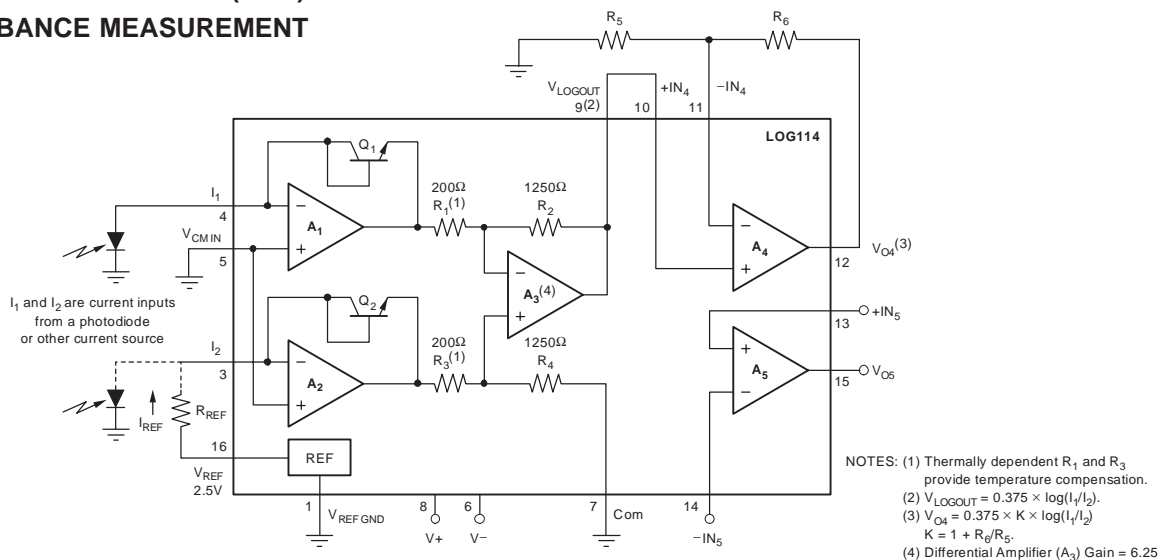

Please be aware that an important notice concerning availability, standard warranty, and use in critical applications of Texas Instruments semiconductor products and disclaimers thereto appears at the end of this data sheet.

All trademarks are the property of their respective owners.

ABSOLUTE MAXIMUM RATINGS(1)

Supply Voltage, V+ to V–	12V
Signal Input Terminals, Voltage(2)	(V–) –0.5V to (V+) + 0.5V
Current(2)	±10mA
Output Short-Circuit(3)	Continuous
Operating Temperature	–40°C to +85°C
Storage Temperature	–55°C to +125°C
Junction Temperature	+150°C
ESD Rating (Human Body Model)	2000V

- (1) Stresses above these ratings may cause permanent damage. Exposure to absolute maximum conditions for extended periods may degrade device reliability. These are stress ratings only, and functional operation of the device at these or any other conditions beyond those specified is not implied.
- (2) Input terminals are diode-clamped to the power-supply rails. Input signals that can swing more than 0.5V beyond the supply rails should be current-limited to 10mA or less.
- (3) Short-circuit to ground.



This integrated circuit can be damaged by ESD. Texas Instruments recommends that all integrated circuits be handled with appropriate precautions. Failure to observe proper handling and installation procedures can cause damage.

ESD damage can range from subtle performance degradation to complete device failure. Precision integrated circuits may be more susceptible to damage because very small parametric changes could cause the device not to meet its published specifications.

PRECISION CURRENT MEASUREMENT PRODUCTS

FEATURES	PRODUCT
Logarithmic Transimpedance Amplifier, 5V, Eight Decades	LOG114
Logarithmic Transimpedance, 36V, 7.5 Decades	LOG112
Resistor-Feedback Transimpedance, 5V, 5.5 Decades	OPA380, OPA381
Switched Integrator Transimpedance, Six Decades	IVC102
Direct Digital Converter, Six Decades	DDC112

ORDERING INFORMATION(1)

PRODUCT	PACKAGE-LEAD	PACKAGE DESIGNATOR	PACKAGE MARKING
LOG114	QFN-16	RGV	LOG114

(1) For the most current package and ordering information, see the Package Option Addendum at the end of this document, or see the TI web site at www.ti.com.

PIN CONFIGURATION

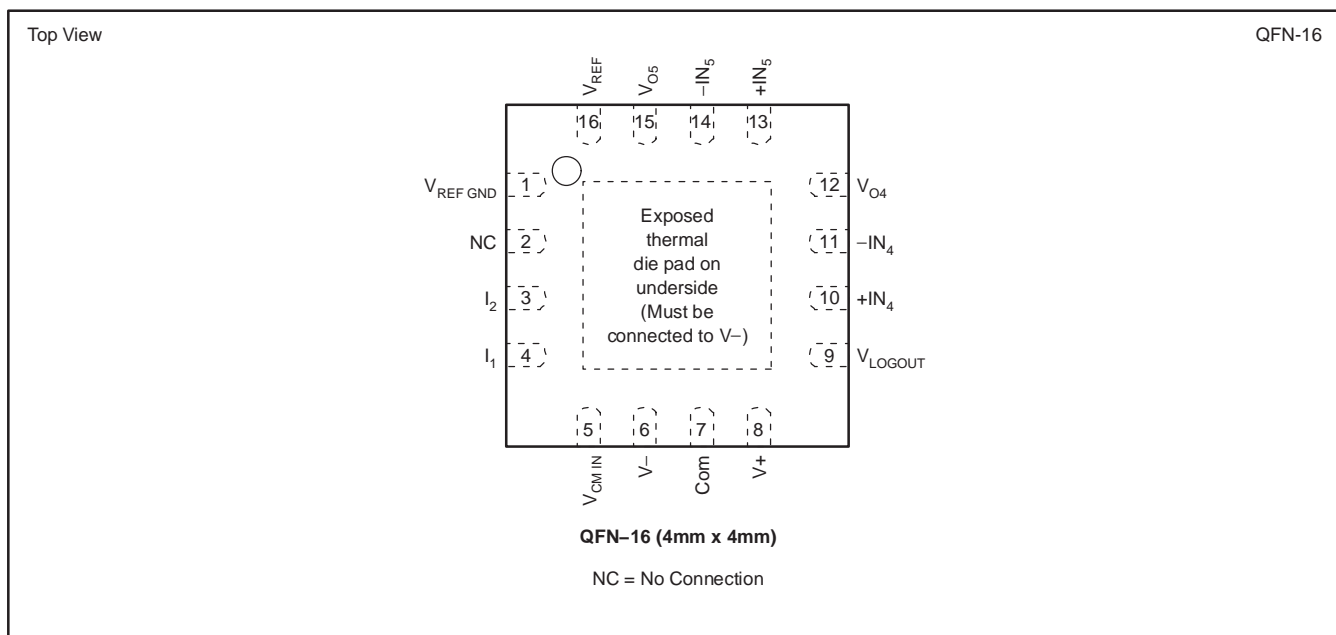

ELECTRICAL CHARACTERISTICS: $V_S = \pm 5V$
Boldface limits apply over the specified temperature range, $T_A = -5^\circ\text{C}$ to $+75^\circ\text{C}$.

 All specifications at $T_A = +25^\circ\text{C}$, $R_{V\text{LOGOUT}} = 10\text{k}\Omega$, $V_{\text{CM}} = \text{GND}$, unless otherwise noted.

PARAMETER	CONDITIONS	LOG114			UNITS
		MIN	TYP	MAX	
CORE LOG FUNCTION	$I_{\text{IN}}/V_{\text{OUT}}$ Equation	$V_O = (0.375V) \text{Log}(I_1/I_2)$			V
LOG CONFORMITY ERROR⁽¹⁾					
Initial	1nA to 100 μ A (5 decades)		0.1	0.2	%
	100pA to 3.5mA (7.5 decades)		0.009	0.017	dB
			0.9		%
			0.08		dB
Over Temperature	1mA to 10mA	See Typical Characteristics			
	1nA to 100μA (5 decades)		0.1	0.4	%
	100pA to 3.5mA (7.5 decades)		0.5		%
	1mA to 10mA	See Typical Characteristics			%
TRANSFER FUNCTION (GAIN)⁽²⁾					
Initial Scaling Factor	100pA to 10mA		0.375		V/decade
Scaling Factor Error	1nA to 100 μ A		0.4	± 2.5	%
			0.035	0.21	dB
Over Temperature	T_{MIN} to T_{MAX}		1.5	± 3.5	%
	$+15^\circ\text{C}$ to $+50^\circ\text{C}$		0.7	± 3	%
INPUT, A_1 and A_2					
Offset Voltage	V_{OS}		± 1	± 4	mV
vs Temperature	dV/dT		± 15		$\mu\text{V}/^\circ\text{C}$
vs Power Supply	PSRR	$V_S = \pm 2.25V$ to $\pm 5.5V$	75	400	$\mu\text{V}/V$
Input Bias Current	I_B		± 5		pA
vs Temperature		T_{MIN} to T_{MAX}	Doubles every 10°C		
Input Common-Mode Voltage Range	V_{CM}		(V-) +1.5 to (V+) -1.5		V
Voltage Noise	e_n	$f = 0.1\text{Hz}$ to 10kHz	3		μVrms
		$f = 1\text{kHz}$	30		$\text{nV}/\sqrt{\text{Hz}}$
Current Noise	i_n	$f = 1\text{kHz}$	4		$\text{fA}/\sqrt{\text{Hz}}$
OUTPUT, A_3 (V_{LOGOUT})					
Output Offset, V_{OSO} , Initial	V_{OSO}		± 11	± 50	mV
Over Temperature		T_{MIN} to T_{MAX}	± 15	± 65	mV
Full-Scale Output (FSO) ⁽³⁾			(V-) + 0.6	(V+) - 0.6	V
Gain Bandwidth Product	GBW	$I_{\text{IN}} = 1\mu\text{A}$	50		MHz
Short-Circuit Current	I_{SC}		± 18		mA
Capacitive Load			100		pF
OP AMP, A_4 and A_5					
Input Offset Voltage	V_{OS}		± 250	± 1000	μV
vs Temperature	dV/dT	T_{MIN} to T_{MAX}	± 2		$\mu\text{V}/^\circ\text{C}$
vs Supply	PSRR	$V_S = \pm 4.5V$ to $\pm 5.5V$	30	250	$\mu\text{V}/V$
vs Common-Mode Voltage	CMRR		74		dB
Input Bias Current	I_B		-1		μA
Input Offset Current	I_{OS}		± 0.05		μA
Input Voltage Range			(V-)	(V+) - 2	V
Input Noise $f = 0.1\text{Hz}$ to 10Hz			2		μVpp
$f = 1\text{kHz}$			13		$\text{nV}/\sqrt{\text{Hz}}$
Current Noise	i_n		2		$\text{pA}/\sqrt{\text{Hz}}$
Open-Loop Voltage Gain	A_{OL}		100		dB
Gain Bandwidth Product	GBW		15		MHz
Slew Rate	SR		5		V/ μs
Settling Time 0.01%	t_S	$G = -1$, 3V Step, $C_L = 100\text{pF}$	1.5		μs
Rated Output			(V-) + 0.5	(V+) - 0.5	V
Short-Circuit Current	I_{SC}		+4/-10		mA

ELECTRICAL CHARACTERISTICS: $V_S = \pm 5V$ (continued)

Boldface limits apply over the specified temperature range, $T_A = -5^\circ C$ to $+75^\circ C$.

All specifications at $T_A = +25^\circ C$, $R_{VLOGOUT} = 10k\Omega$, $V_{CM} = GND$, unless otherwise noted.

PARAMETER	CONDITIONS	LOG114			UNITS
		MIN	TYP	MAX	
TOTAL ERROR(4, 5)		See Typical Characteristics			
FREQUENCY RESPONSE, Core Log⁽⁶⁾ BW, 3dB I_1 or $I_2 =$	$I_{AC} = 10\%$ of I_{DC} value, $I_{REF} = 1\mu A$				
1nA			5		kHz
10nA			12		kHz
100nA			120		kHz
1 μA			2.3		MHz
10 μA to 1mA (ratio 1:100)			> 5		MHz
1mA to 3.5mA (ratio 1:3.5)			> 5		MHz
3.5mA to 10mA (ratio 1:2.9)			> 5		MHz
Step Response	$I_{REF} = 1\mu A$				
Increasing (I_1 or I_2)					
8nA to 240nA (ratio 1:30)			0.7		μs
10nA to 100nA (ratio 1:10)			1.5		μs
10nA to 1 μA (ratio 1:100)			0.15		μs
10nA to 10 μA (ratio 1:1k)			0.07		μs
10nA to 1mA (ratio 1:100k)			0.06		μs
1mA to 10mA (ratio 1:10)			1		μs
Decreasing (I_1 or I_2)	$I_{REF} = 1\mu A$				
8nA to 240nA (ratio 1:30)			1		μs
10nA to 100nA (ratio 1:10)			2		μs
10nA to 1 μA (ratio 1:100)			0.25		μs
10nA to 10 μA (ratio 1:1k)			0.05		μs
10nA to 1mA (ratio 1:100k)			0.03		μs
1mA to 10mA (ratio 1:10)			1		μs
VOLTAGE REFERENCE					
Bandgap Voltage			2.5		V
Error, Initial			± 0.15	± 1	%
vs Temperature			± 25		ppm/$^\circ C$
vs Supply	$V_S = \pm 4.5V$ to $\pm 5.5V$		± 30		ppm/V
vs Load	$I_O = \pm 2mA$		± 200		ppm/mA
Short-Circuit Current			± 10		mA
POWER SUPPLY					
Dual Supply Operating Range	V_S		± 2.4	± 5.5	V
Quiescent Current	I_Q	$I_O = 0$	± 10	± 15	mA
TEMPERATURE RANGE					
Specification, T_{MIN} to T_{MAX}			-5	+75	$^\circ C$
Operating			-40	+85	$^\circ C$
Storage			-55	+125	$^\circ C$
Thermal Resistance, θ_{JA}			62		$^\circ C/W$

- (1) Log conformity error is peak deviation from the best-fit straight line of V_O vs $\text{Log}(I_1/I_2)$ curve expressed as a percent of peak-to-peak full-scale output. Scale factor, K, equals 0.375V output per decade of input current.
- (2) Scale factor of core log function is trimmed to 0.375V output per decade change of input current.
- (3) Specified by design.
- (4) Worst-case total error for any ratio of I_1/I_2 , as the largest of the two errors, when I_1 and I_2 are considered separately.
- (5) Total error includes offset voltage, bias current, gain, and log conformity.
- (6) Small signal bandwidth (3dB) and transient response are a function of the level of input current. Smaller input current amplitude results in lower bandwidth.

ELECTRICAL CHARACTERISTICS: $V_S = +5V$
Boldface limits apply over the specified temperature range, $T_A = -5^\circ\text{C}$ to $+75^\circ\text{C}$.

 All specifications at $T_A = +25^\circ\text{C}$, $R_{V\text{LOGOUT}} = 10\text{k}\Omega$, $V_{\text{CM}} = +2.5\text{V}$, unless otherwise noted.

PARAMETER	CONDITIONS	LOG114			UNITS
		MIN	TYP	MAX	
CORE LOG FUNCTION	$I_{\text{IN}}/V_{\text{OUT}}$ Equation	$V_O = (0.375V) \text{Log} (I_1/I_2) + V_{\text{CM}}$			V
LOG CONFORMITY ERROR⁽¹⁾					
Initial	1nA to 100 μ A (5 decades)		0.1	0.25	%
	100pA to 3.5mA (7.5 decades)		0.009	0.022	dB
			0.9		%
			0.08		dB
Over Temperature	1mA to 10mA 1nA to 100μA (5 decades) 100pA to 3.5mA (7.5 decades) 1mA to 10mA	See Typical Characteristics			
			0.1	0.4	%
			0.5		%
		See Typical Characteristics			
TRANSFER FUNCTION (GAIN)⁽²⁾					
Initial Scaling Factor	10nA to 100 μ A		0.375		V/decade
Scaling Factor Error	1nA to 100 μ A		0.4	± 2.5	%
			0.035	0.21	dB
Over Temperature	T_{MIN} to T_{MAX} $+15^\circ\text{C}$ to $+50^\circ\text{C}$		0.035	± 3.5	%
			0.7	± 3	%
INPUT, A_1 and A_2					
Offset Voltage	V_{OS}		± 1	± 7	mV
vs Temperature	dV/dT	T_{MIN} to T_{MAX}	± 30		$\mu\text{V}/^\circ\text{C}$
vs Power Supply	PSRR	$V_S = +4.5\text{V}$ to $+5.5\text{V}$	300		$\mu\text{V}/\text{V}$
Input Bias Current	I_B		± 5		pA
vs Temperature		T_{MIN} to T_{MAX}	Doubles every 10°C		
Input Common-Mode Voltage Range	V_{CM}		(V-) +1.5 to (V+) -1.5		V
Voltage Noise	e_n	$f = 0.1\text{Hz}$ to 10kHz	3		μV_{rms}
		$f = 1\text{kHz}$	30		$\text{nV}/\sqrt{\text{Hz}}$
Current Noise	i_n	$f = 1\text{kHz}$	4		$\text{fA}/\sqrt{\text{Hz}}$
OUTPUT, A_3 (V_{LOGOUT})					
Output Offset, V_{OSO} , Initial	V_{OSO}		± 14	± 65	mV
Over Temperature		T_{MIN} to T_{MAX}	± 18	± 80	mV
Full Scale Output (FSO) ⁽³⁾		$V_S = +5\text{V}$	(V-) + 0.6	(V+) - 0.6	V
Gain Bandwidth Product	GBW	$I_{\text{IN}} = 1\mu\text{A}$	50		MHz
Short-Circuit Current	I_{SC}		± 18		mA
Capacitive Load			100		pF
OP AMP, A_4 and A_5					
Input Offset Voltage	V_{OS}		± 250	± 4000	μV
vs Temperature	dV/dT	T_{MIN} to T_{MAX}	± 2		$\mu\text{V}/^\circ\text{C}$
vs Supply	PSRR	$V_S = +4.8\text{V}$ to $+5.5\text{V}$	30		$\mu\text{V}/\text{V}$
vs Common-Mode Voltage	CMRR		70		dB
Input Bias Current	I_B		-1		μA
Input Offset Current	I_{OS}		± 0.05		μA
Input Voltage Range			(V-)	(V+) - 1.5	V
Input Noise $f = 0.1\text{Hz}$ to 10Hz			1		μV_{PP}
$f = 1\text{kHz}$			28		$\text{nV}/\sqrt{\text{Hz}}$
Current Noise	i_n		2		$\text{pA}/\sqrt{\text{Hz}}$
Open-Loop Voltage Gain	A_{OL}		100		dB
Gain Bandwidth Product	GBW		15		MHz
Slew Rate	SR		5		V/ μs
Settling Time 0.01%	t_S	$G = -1$, 3V Step, $C_L = 100\text{pF}$	1.5		μs
Rated Output			(V-) + 0.5	(V+) - 0.5	V
Short-Circuit Current	I_{SC}		+4/-10		mA

TYPICAL CHARACTERISTICS: $V_S = \pm 5V$

All specifications at $T_A = +25^\circ C$, $R_{VLOGOUT} = 10k\Omega$, $V_{CM} = GND$, unless otherwise noted.

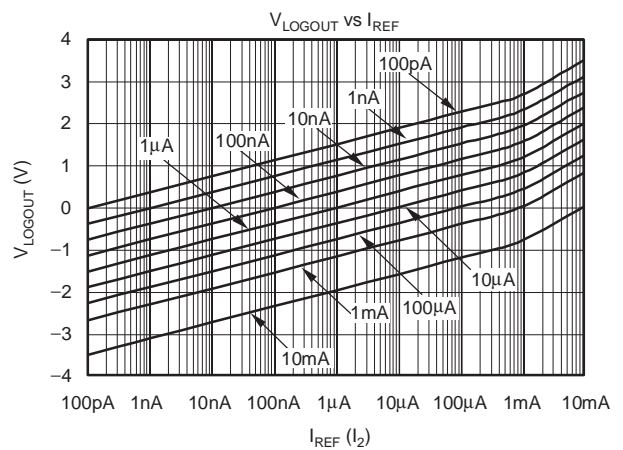
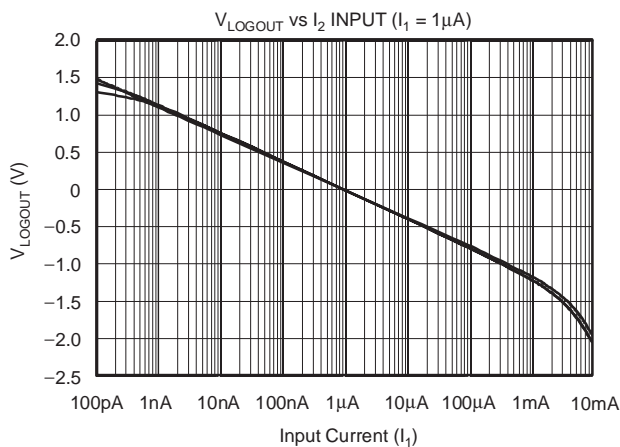
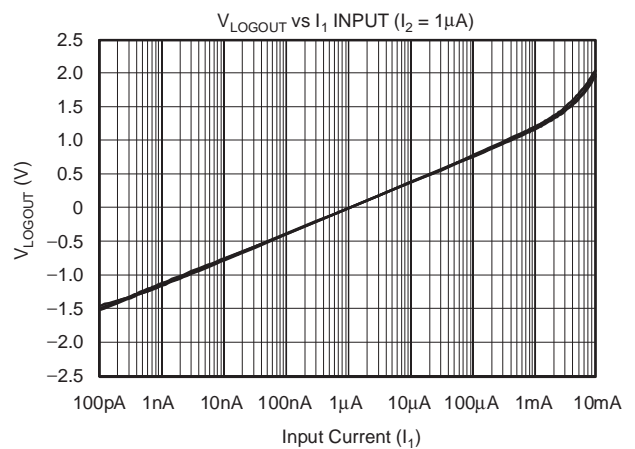
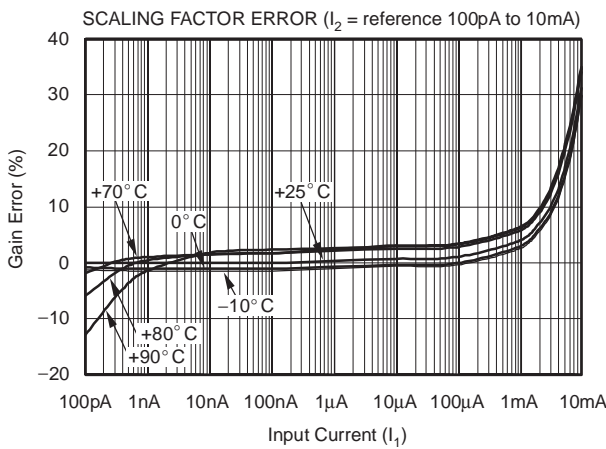
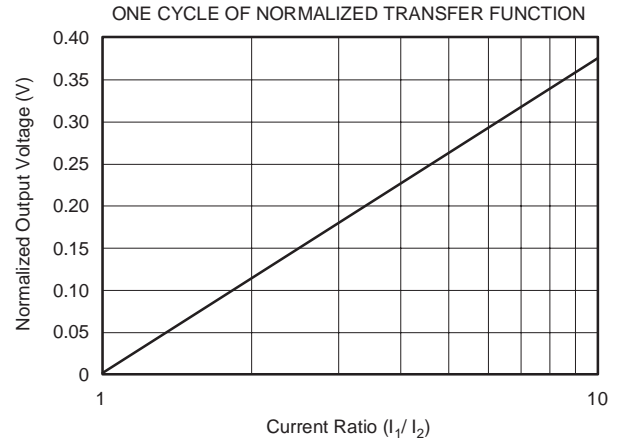
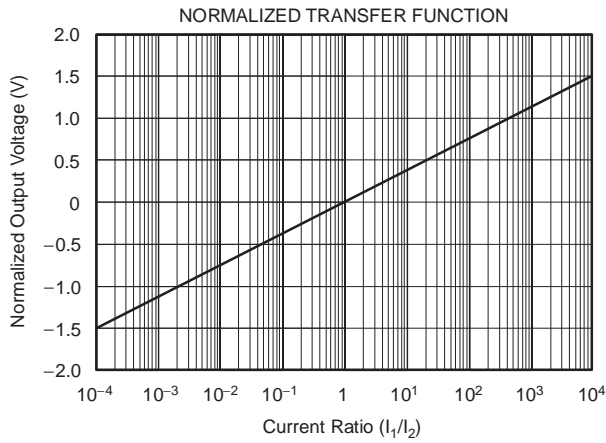

SBOS301A – MAY 2004 – REVISED MARCH 2007

TYPICAL CHARACTERISTICS: $V_S = \pm 5V$ (continued)

All specifications at $T_A = +25^\circ C$, $R_{VLOGOUT} = 10k\Omega$, $V_{CM} = GND$, unless otherwise noted.

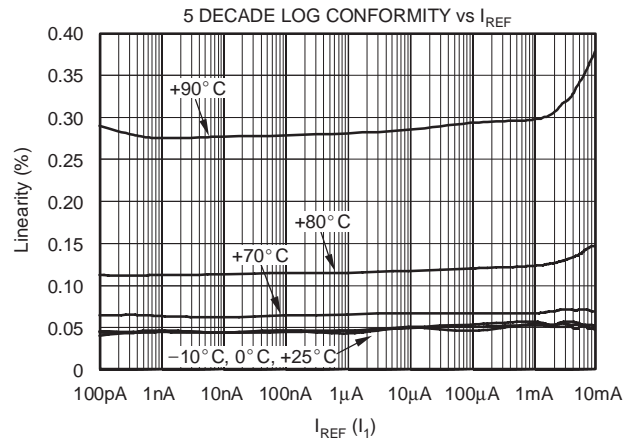
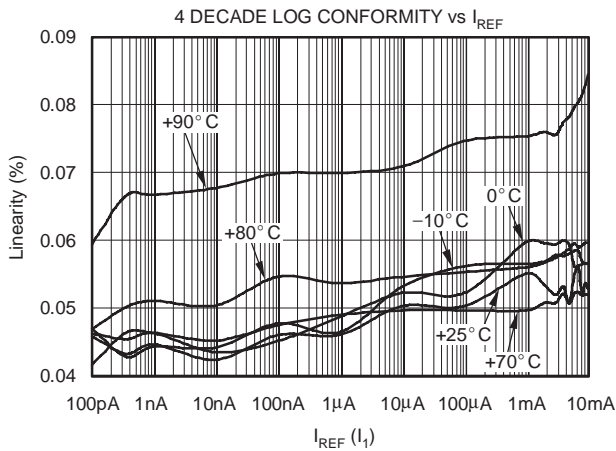
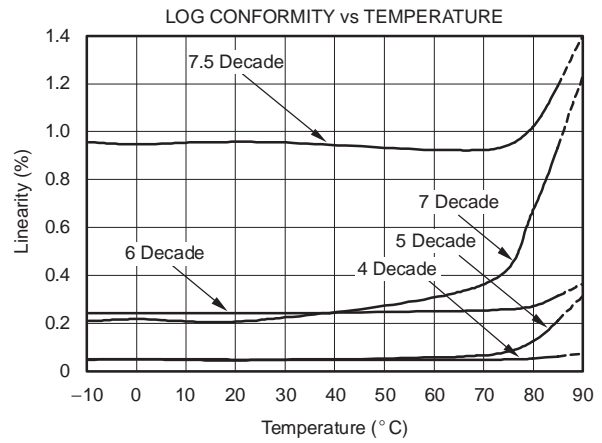
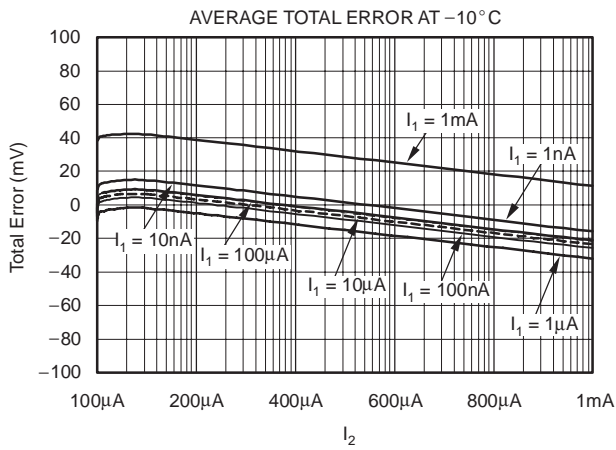
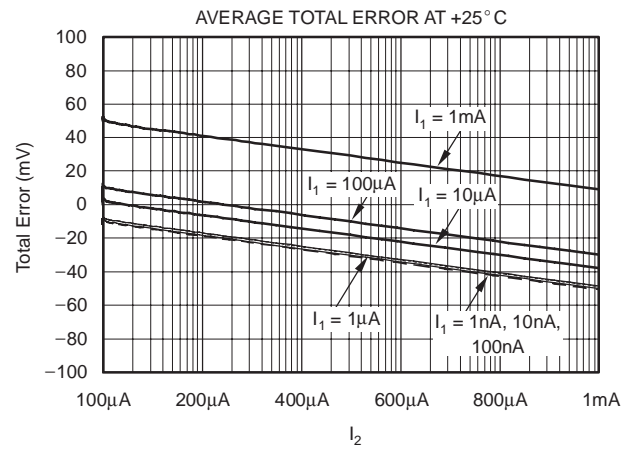
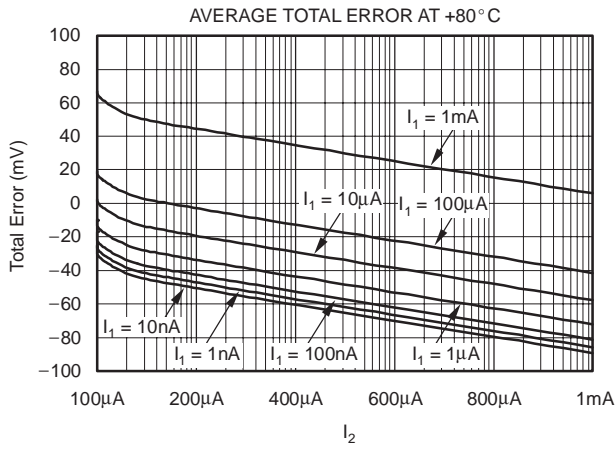

TYPICAL CHARACTERISTICS: $V_S = \pm 5V$ (continued)

All specifications at $T_A = +25^\circ C$, $R_{VLOGOUT} = 10k\Omega$, $V_{CM} = GND$, unless otherwise noted. For ac measurements, small signal means up to approximately 10% of dc level.

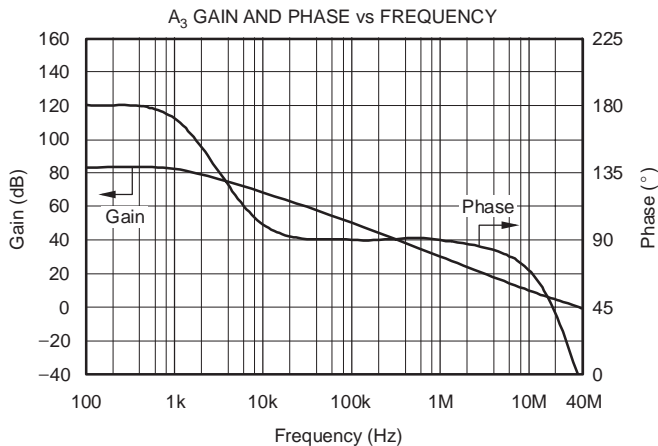
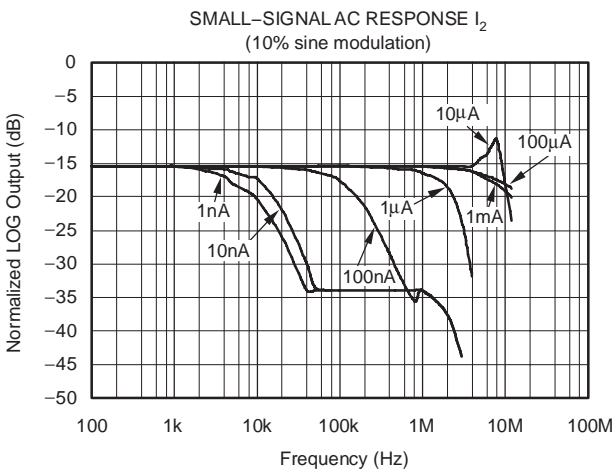
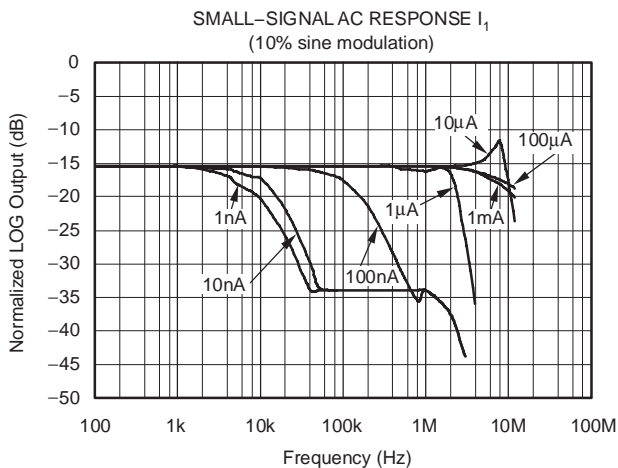
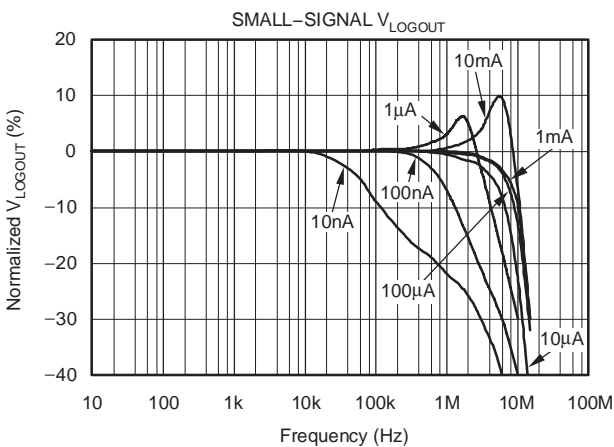
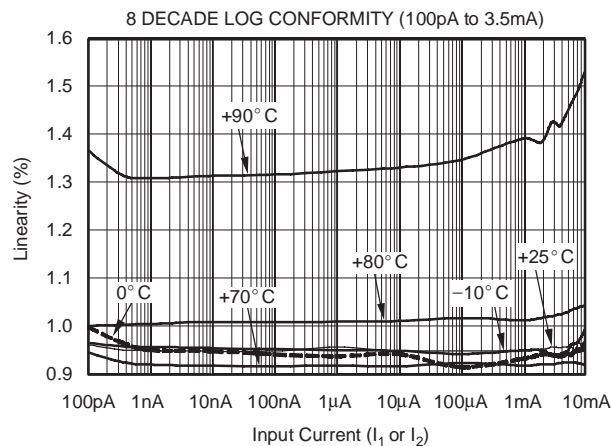
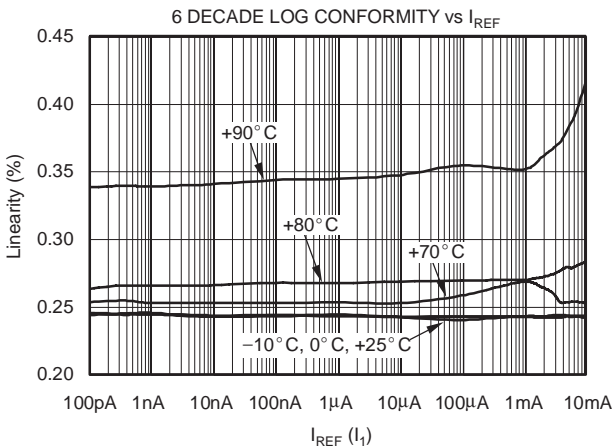

TYPICAL CHARACTERISTICS: $V_S = \pm 5V$ (continued)

All specifications at $T_A = +25^\circ C$, $R_{VLOGOUT} = 10k\Omega$, $V_{CM} = GND$, unless otherwise noted.

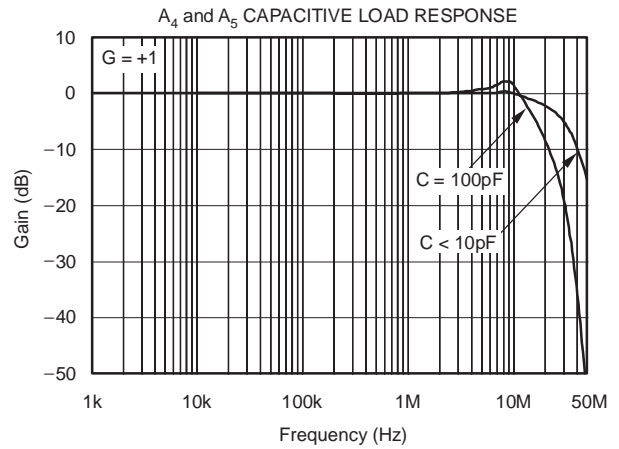
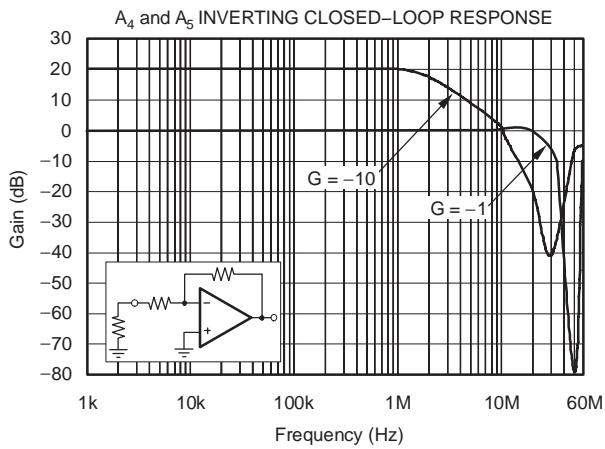
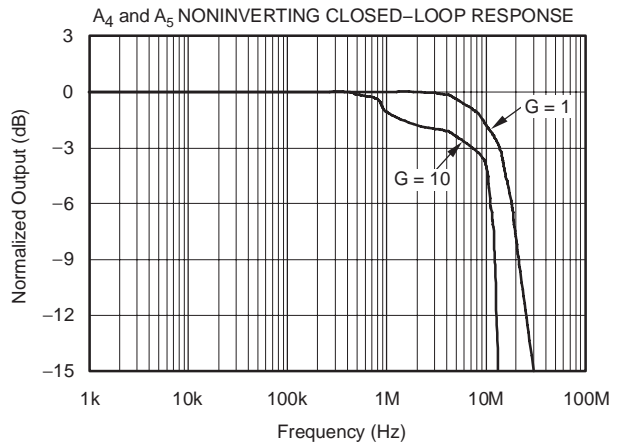
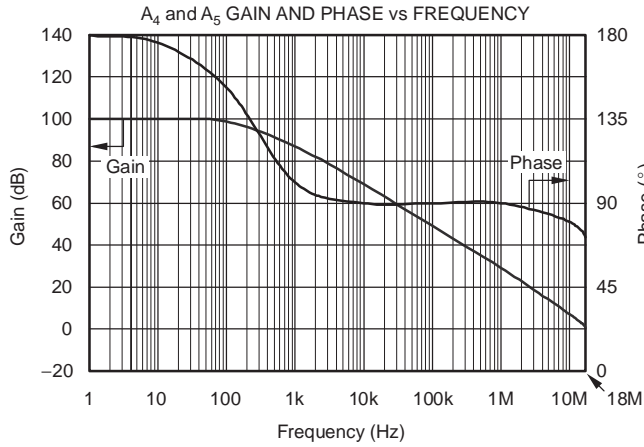

APPLICATIONS INFORMATION

OVERVIEW

The LOG114 is a precision logarithmic amplifier that is capable of measuring currents over a dynamic range of eight decades. It computes the logarithm, or log ratio, of an input current relative to a reference current according to equation (1).

$$V_{\text{LOGOUT}} = 0.375 \times \log_{10} \left(\frac{I_1}{I_2} \right) \quad (1)$$

The output at V_{LOGOUT} can be digitized directly, or scaled for an ADC input using an uncommitted or external op amp.

An offsetting voltage (V_{Com}) can be connected to the Com pin to raise the voltage at V_{LOGOUT} . When an offsetting voltage is used, the transfer function becomes:

$$V_{\text{LOGOUT}} = 0.375 \times \log_{10} \left(\frac{I_1}{I_2} \right) + V_{\text{Com}} \quad (2)$$

Either I_1 or I_2 can be held constant to serve as the reference current, with the other input being used for the input signal. The value of the reference current is selected such that the output at V_{LOGOUT} (pin 9) is zero when the reference current and input current are equal. An on-chip 2.5V reference is provided for use in generating the reference current.

Two additional amplifiers, A_4 and A_5 , are included in the LOG114 for use in scaling, offsetting, filtering, threshold detection, or other functions.

BASIC CONNECTIONS

Figure 1 and Figure 2 show the LOG114 in typical dual and single-supply configurations, respectively. To reduce the influence of lead inductance of power-supply lines, it is recommended that each supply be bypassed with a 10 μ F tantalum capacitor in parallel with a 1000pF ceramic capacitor as shown in Figure 1 and Figure 2. Connecting these capacitors as close to the LOG114 V_+ supply pin to ground as possible improves supply-related noise rejection.

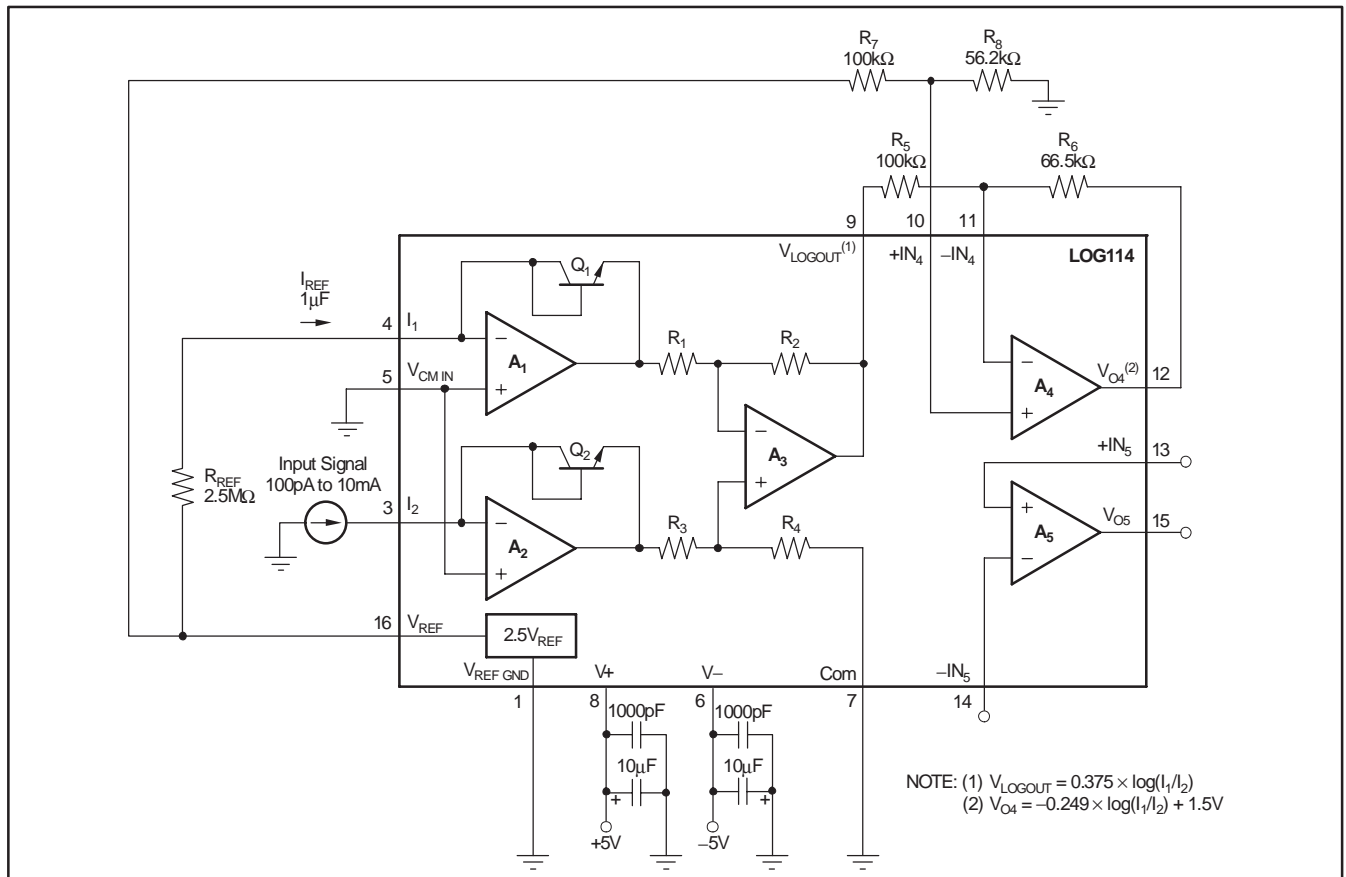

Figure 1. Dual Supply Configuration Example for Best Accuracy Over Eight Decades.

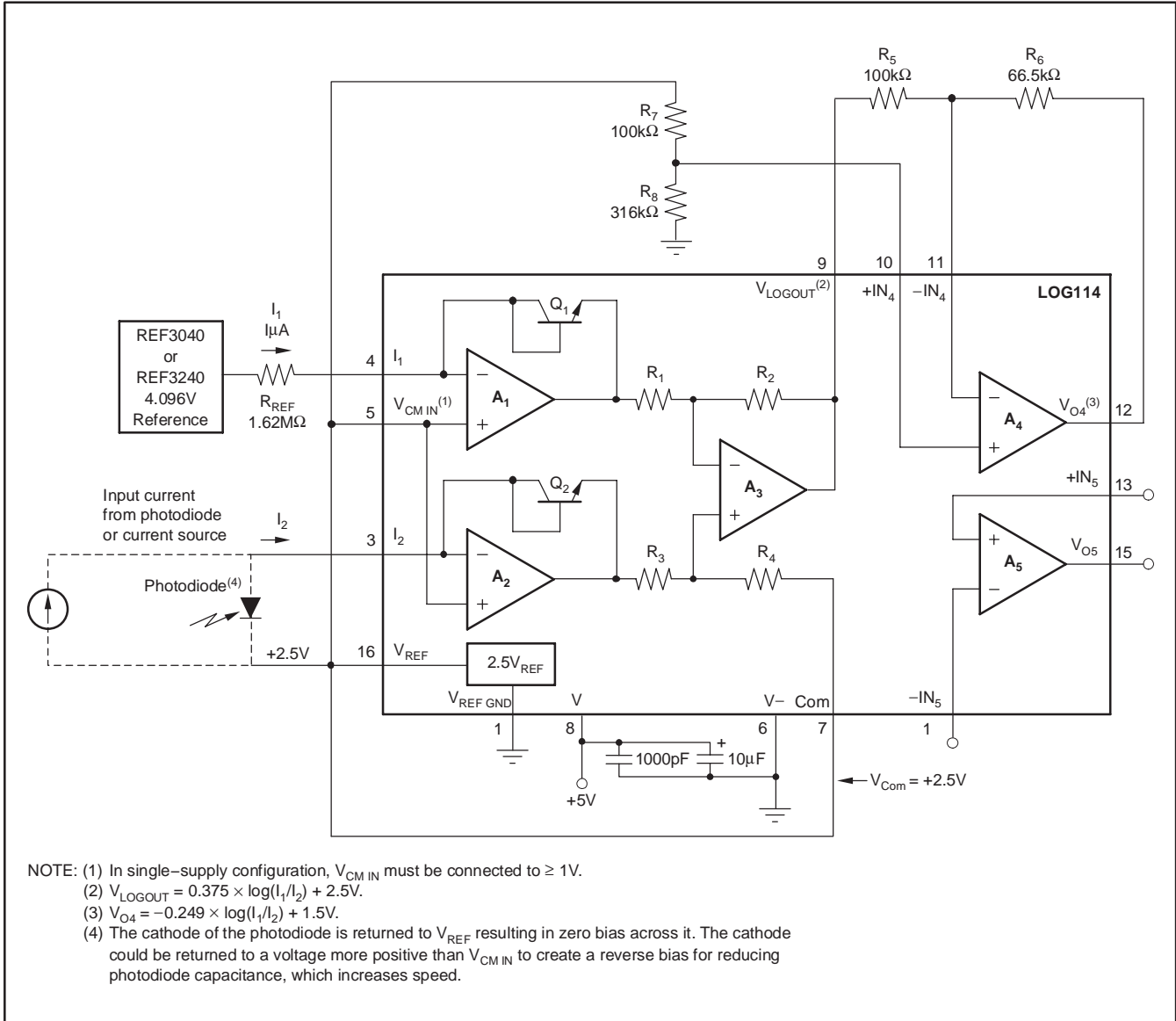

Figure 2. Single-Supply Configuration Example for Measurement Over Eight Decades.

DESIGN EXAMPLE FOR DUAL-SUPPLY CONFIGURATION

Given these conditions:

- $V_+ = 5V$ and $V_- = -5V$
 - $100pA \leq$ Input signal
 - The stage following the LOG114 is an analog-to-digital converter (ADC) with +5V supply and +2.5V reference voltage, so V_{O4} swings from +0.5V to +2.5V.
1. Due to LOG114 symmetry, you can choose either I_1 or I_2 as the signal input pin. Choosing I_1 as the reference makes the resistor network around A_4 simpler. (Note: Current must flow into pins 3 (I_1) and pin 4 (I_2).)
 2. Select the magnitude of the reference current. Since the signal (I_2) spans eight decades, set I_1 to $1\mu A$ – four decades above the minimum I_2 value. (Note that it does not have to be placed in the middle. If I_2 spanned seven decades, I_1 could be set three decades above the minimum and four decades below the maximum I_2 value.) This configuration results in more swing amplitude in the negative direction, which provides more sensitivity (ΔV_{O4} per ΔI_2) when the current signal decreases.
 3. Using Equation (1) calculate the expected range of log outputs at V_{LOGOUT} :

For $I_2 = 10mA$:

$$\begin{aligned}
 V_{LOGOUT} &= 0.375 \times \log\left(\frac{I_1}{I_2}\right) \\
 &= 0.375 \times \log\left(\frac{1\mu A}{10mA}\right) = -1.5V
 \end{aligned}$$

For $I_2 = 100pA$:

$$\begin{aligned}
 V_{LOGOUT} &= 0.375 \times \log\left(\frac{I_1}{I_2}\right) \\
 &= 0.375 \times \log\left(\frac{1\mu A}{100pA}\right) = +1.5V
 \end{aligned}
 \tag{3}$$

Therefore, the expected voltage range at the output of amplifier A_3 is:

$$-1.5V \leq V_{LOGOUT} \leq +1.5V \tag{4}$$

4. The A_4 amplifier scales and offsets the V_{LOGOUT} signal for use by the ADC using the equation:

$$V_{O4} = -S_{FACTOR} \times (V_{LOGOUT}) + V_{OFFSET} \tag{5}$$

The A_4 amplifier is specified with a rated output swing capability from $(V_-) +0.5V$ to $(V_+) - 0.5V$.

Therefore, choose the final A_4 output:

$$0V \leq V_{O4} \leq +2.5V$$

This output results in a 2.5V range for the 3V V_{LOGOUT} range, or 2.5V/3V scaling factor.

5. When $I_2 = 10mA$, $V_{LOGOUT} = -1.5V$. Using the equation in step 5:

$$\begin{aligned}
 V_{O4} &= -S_{FACTOR} \times (V_{LOGOUT}) + V_{OFFSET} \\
 0V &= -2.5V/3V(-1.5V) + V_{OFFSET}
 \end{aligned}
 \tag{6}$$

Therefore, $V_{OFFSET} = 0V$

The A_4 amplifier configuration for $V_{O4} = -2.5/3(V_{LOGOUT}) + 0V$ is seen in Figure 3.

The overall transfer function is:

$$V_{O4} = -0.249 \times \log\left(\frac{I_1}{I_2}\right) + 1.5V \tag{7}$$

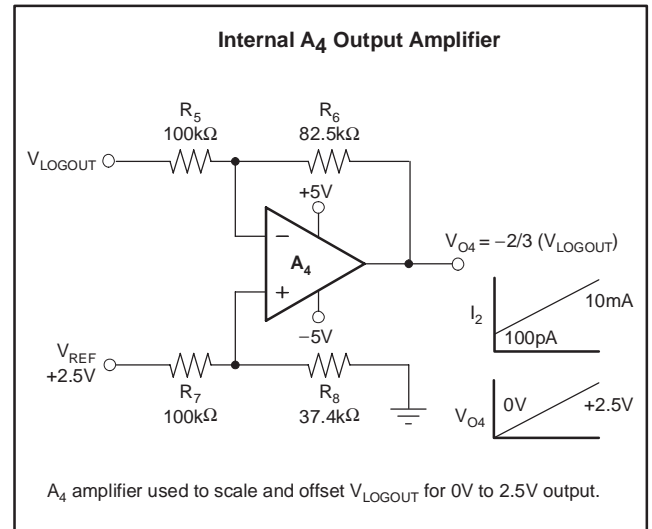

Figure 3. Operational Amplifier Configuration for Scaling the Output Going to ADC Stage.

DESIGN EXAMPLE FOR SINGLE-SUPPLY CONFIGURATION

Given these conditions:

- $V_+ = 5V$
 - $V_- = GND$
 - $100pA \leq \text{Input signal} \leq 10mA$
 - The stage following the LOG114 is an analog to digital converter (ADC) with +5V supply and +2.5V reference voltage
1. Choose either I_1 or I_2 as the signal input pin. For this example, I_2 is used. Choosing I_1 as the reference current makes the resistor network around A_4 simpler. (Note: Current only flows into the I_1 and I_2 pins.)
 2. Select the magnitude of the reference current. Since the signal (I_2) spans eight decades, set I_1 to $1\mu A$ – four decades above the minimum I_2 value, and four decades below the maximum I_2 value. (Note that it does not have to be placed in the middle. If I_2 spanned seven decades, I_1 could be set three decades above the minimum and four decades below the maximum I_2 value.) This configuration results in more swing amplitude in the negative direction, which provides more sensitivity (ΔV_{O4} per ΔI_2) when the current signal decreases.
 3. Using Equation (1) calculate the expected range of log outputs at V_{LOGOUT} :

For $I_2 = 10mA$:

$$\begin{aligned} V_{LOGOUT} &= 0.375 \times \log\left(\frac{I_1}{I_2}\right) \\ &= 0.375 \times \log\left(\frac{1\mu A}{10mA}\right) = -1.5V \end{aligned}$$

For $I_2 = 100pA$:

$$\begin{aligned} V_{LOGOUT} &= 0.375 \times \log\left(\frac{I_1}{I_2}\right) \\ &= 0.375 \times \log\left(\frac{1\mu A}{100pA}\right) = +1.5V \end{aligned} \quad (8)$$

Therefore, the expected voltage range at the output of amplifier A_3 is:

$$-1.5V \leq V_{LOGOUT} \leq +1.5V \quad (9)$$

This result would be fine in a dual-supply system ($V_+ = +5V$, $V_- = -5V$) where the output can swing below ground, but does not work in a single supply +5V system. Therefore, an offset voltage must be added to the system.

4. Select an offset voltage, V_{Com} to use for centering the output between $(V_-) + 0.6V$ and $(V_+) - 0.6V$, which is the full-scale output capability of the A_3 amplifier. Choosing $V_{Com} = 2.5V$, and recalculating the expected voltage output range for V_{LOGOUT} using Equation (2), results in:

$$+1V \leq V_{LOGOUT} \leq +4V \quad (10)$$

5. The A_4 amplifier scales and offsets the V_{LOGOUT} signal for use by the ADC using the equation:

$$V_{O4} = -S_{FACTOR} \times (V_{LOGOUT}) + V_{OFFSET} \quad (11)$$

The A_4 amplifier is specified with a rated output swing capability from $(V_-) + 0.5V$ to $(V_+) - 0.5V$.

Therefore, choose the final A_4 output:

$$+0.5V \leq V_{O4} \leq +2.5V$$

This output results in a 2V range for the 3V V_{LOGOUT} range, or 2V/3V scaling factor.

6. When $I_2 = 10mA$, $V_{LOGOUT} = +1V$, and $V_{O4} = 2.5V$. Using the equation in step 5:

$$\begin{aligned} V_{O4} &= -S_{FACTOR} \times (V_{LOGOUT}) + V_{OFFSET} \\ 2.5V &= -2V/3V(1V) + V_{OFFSET} \end{aligned} \quad (12)$$

Therefore, $V_{OFFSET} = 3.16V$

The A_4 amplifier configuration for $V_{O4} = -2/3(V_{LOGOUT}) + 3.16$ is seen in Figure 4a.

The overall transfer function is:

$$V_{O4} = -0.249 \times \log\left(\frac{I_1}{I_2}\right) + 1.5V \quad (13)$$

A similar process can be used for configuring an external rail-to-rail output op amp, such as the OPA335. Because the OPA335 op amp can swing down to 0V using a pulldown resistor, R_P , connected to $-5V$ (for details, refer to the OPA335 data sheet, available for download at www.ti.com), the scaling factor is 2.5V/3V and the corresponding V_{OFFSET} is 3.3V. This circuit configuration is shown in Figure 4b.

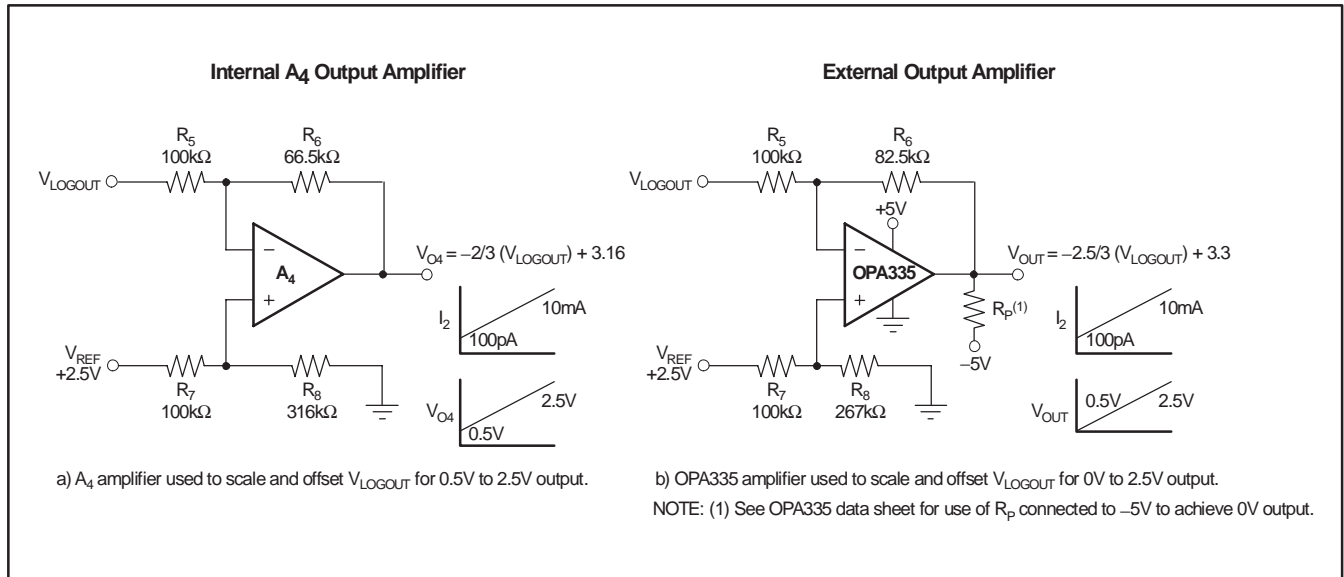

Figure 4. Operational Amplifier Configuration for Scaling and Offsetting the Output Going to ADC Stage.

ADVANTAGES OF DUAL-SUPPLY OPERATION

The LOG114 performs very well on a single +5V supply by level-shifting pin 7 (Com) to half-supply and raising the common-mode voltage (pin 5, $V_{CM IN}$) of the input amplifiers. This level-shift places the input amplifiers in the linear operating range. However, there are also some advantages to operating the LOG114 on dual $\pm 5V$ supplies. These advantages include:

- 1) eliminating the need for the +4.096V precision reference;
- 2) eliminating a small additional source of error arising from the noise and temperature drift of the level-shifting voltage; and
- 3) allowing increased magnitude of a reverse bias voltage on the photodiode.

COM (PIN 7) VOLTAGE RANGE

The voltage on the Com pin is used to bias the differential amplifier, A₃, within its linear range. This voltage can provide an asymmetrical offset of the V_{LOGOUT} voltage.

$V_{CM IN}$ (Pin 5)

The $V_{CM IN}$ pin is used to bias the A₁ and A₂ amplifier into its common-mode input voltage range, $(V-) + 1.5V$ to $(V+) - 1.5V$.

INPUT CURRENT RANGE

To maintain specified accuracy, the input current range of the LOG114 should be limited from 100pA to 3.5mA. Input currents outside of this range may compromise the LOG114 performance. Input currents larger than 3.5mA result in increased nonlinearity. An absolute maximum input current rating of 10mA is included to prevent excessive power dissipation that may damage the input transistor.

SETTING THE REFERENCE CURRENT

When the LOG114 is used to compute logarithms, either I_1 or I_2 can be held constant to become the reference current to which the other is compared.

If I_{REF} is set to the lowest current in the span of the signal current (as shown in the front page figure), V_{LOGOUT} will range from:

$$V_{LOGOUT} = 0.375 \times \log_{10} \left(\frac{I_1 \text{ min}}{I_1 \text{ max signal}} \right) \cong 0V \quad (14)$$

to some maximum value:

$$V_{LOGOUT} = 0.375 \times \log_{10} \left(\frac{I_1 \text{ min}}{I_1 \text{ max signal}} \right) \quad (15)$$

While convenient, this approach does not usually result in best performance, because I_1 min accuracy is difficult to achieve, particularly if it is $< 20nA$.

A better way to achieve higher accuracy is to choose I_{REF} to be in the center of the full signal range. For example, for a signal range of 1nA to 1mA, it is better to use this approach:

$$I_{REF} = I_{SIGNAL \text{ min}} \times \sqrt{1mA/1nA} = 1\mu A \text{ dc} \quad (16)$$

than it is to set $I_{REF} = 1nA$. It is much easier and more precise (that is, dc accuracy, temperature stability, and lower noise) to establish a 1mA dc current level than a 1nA level for the reference current.

The reference current may be derived from a voltage source with one or more resistors. When a single resistor is used, the value may be large depending on I_{REF} . If I_{REF} is 10nA and +2.5V is used:

$$R_{REF} = 2.5V/10nA = 250M\Omega$$

A voltage divider may be used to reduce the value of the resistor, as shown in Figure 5. When using this method, one must consider the possible errors caused by the amplifier input offset voltage. The input offset voltage of amplifier A_1 has a maximum value of 4mV in a $\pm 5V$ sup-

ply system, and a maximum value of 7mV in a +5V supply system. Resistor temperature stability and noise contributions should also be considered.

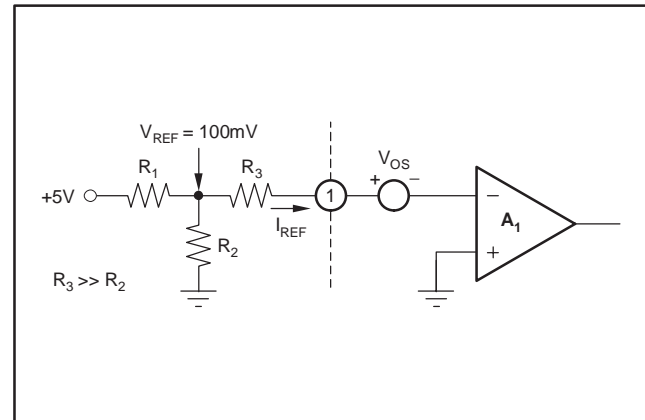

Figure 5. T-Network for Reference Current.

V_{REF} may be an external precision voltage reference, or the on-chip 2.5V voltage reference of the LOG114.

I_{REF} can be derived from an external current source, such as that shown in Figure 6.

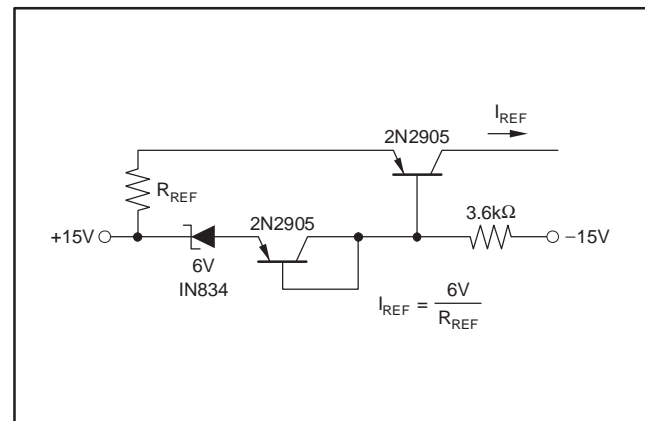

Figure 6. Temperature-Compensated Current Source.

NEGATIVE INPUT CURRENTS

The LOG114 functions only with positive input currents (conventional current flows into input current pins). In

situations where negative input currents are needed, the example circuits in Figure 7, Figure 8, and Figure 9 may be used.

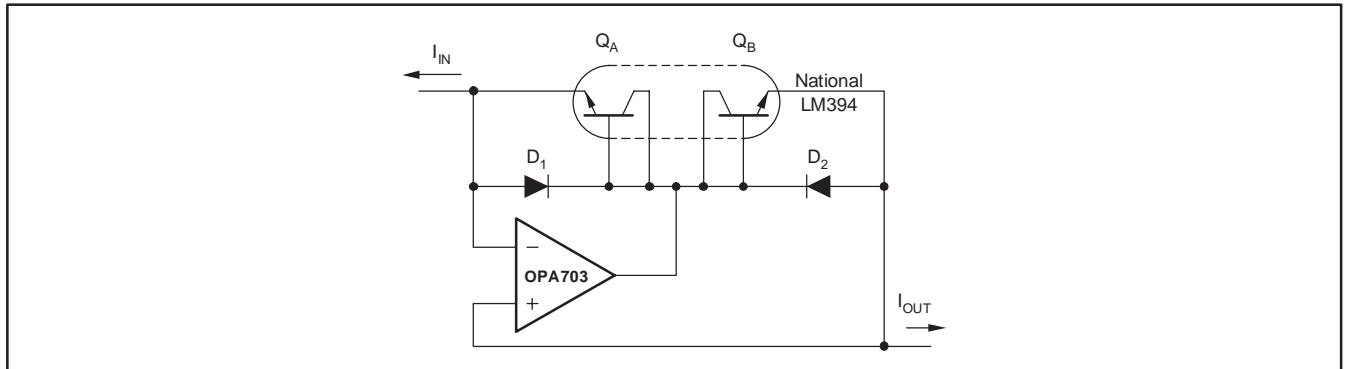

Figure 7. Current Inverter/Current Source.

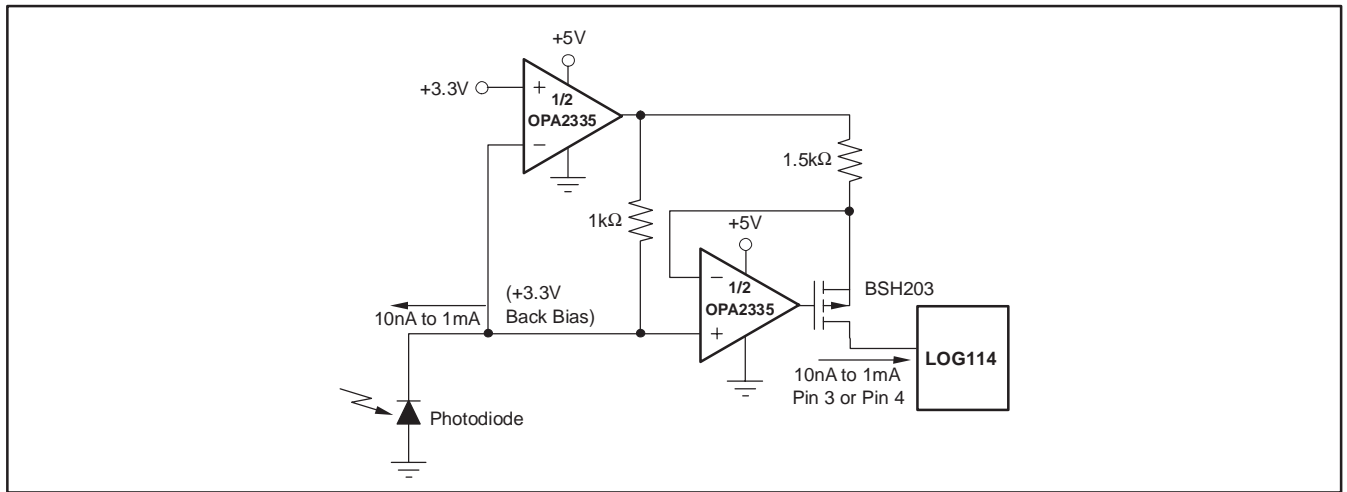

Figure 8. Precision Current Inverter/Current Source.

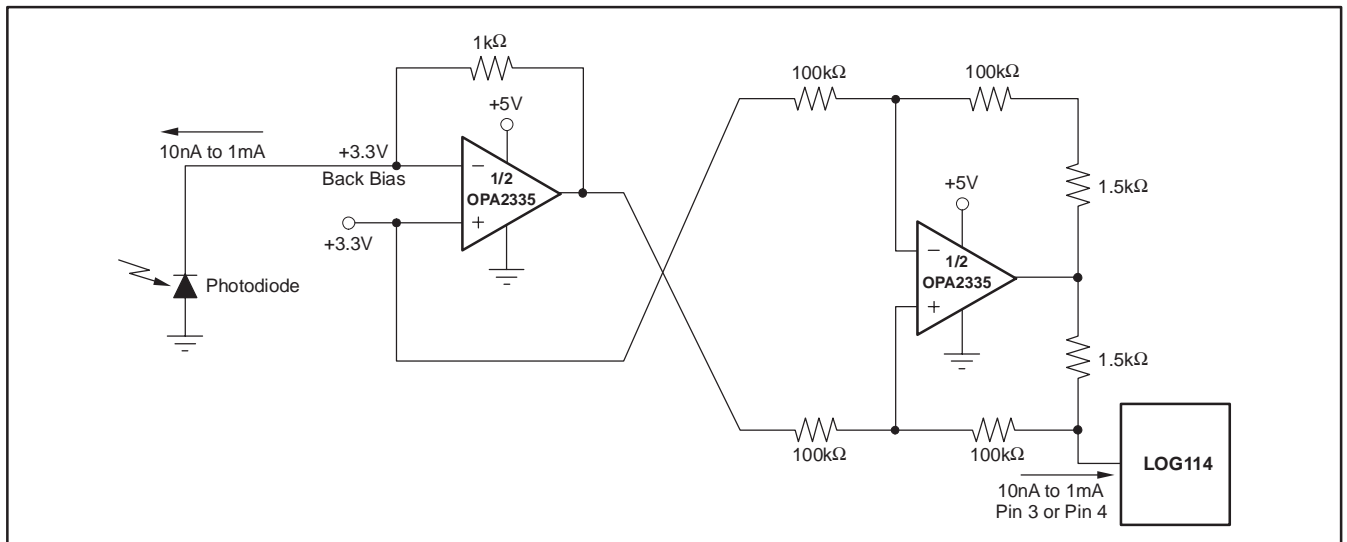

Figure 9. Precision Current Inverter/Current Source.

VOLTAGE INPUTS

The LOG114 provides the best performance with current inputs. Voltage inputs may be handled directly by using a low-impedance voltage source with series resistors, but the dynamic input range is limited to approximately three decades of input voltage. This limitation exists because of the magnitude of the required input voltage and size of the corresponding series resistor. For 10nA of input current, a 10V voltage source and a 1GΩ resistor would be required. Voltage and current

noise from these sources must be considered and can limit the usefulness of this technique.

APPLICATION CIRCUITS

LOG RATIO

One of the more common uses of log ratio amplifiers is to measure absorbance. See Figure 10 for a typical application. Absorbance of the sample is $A = \log \lambda_1'/\lambda_1$. If D_1 and D_2 are matched, $A \propto (0.375V) \log(I_1/I_2)$.

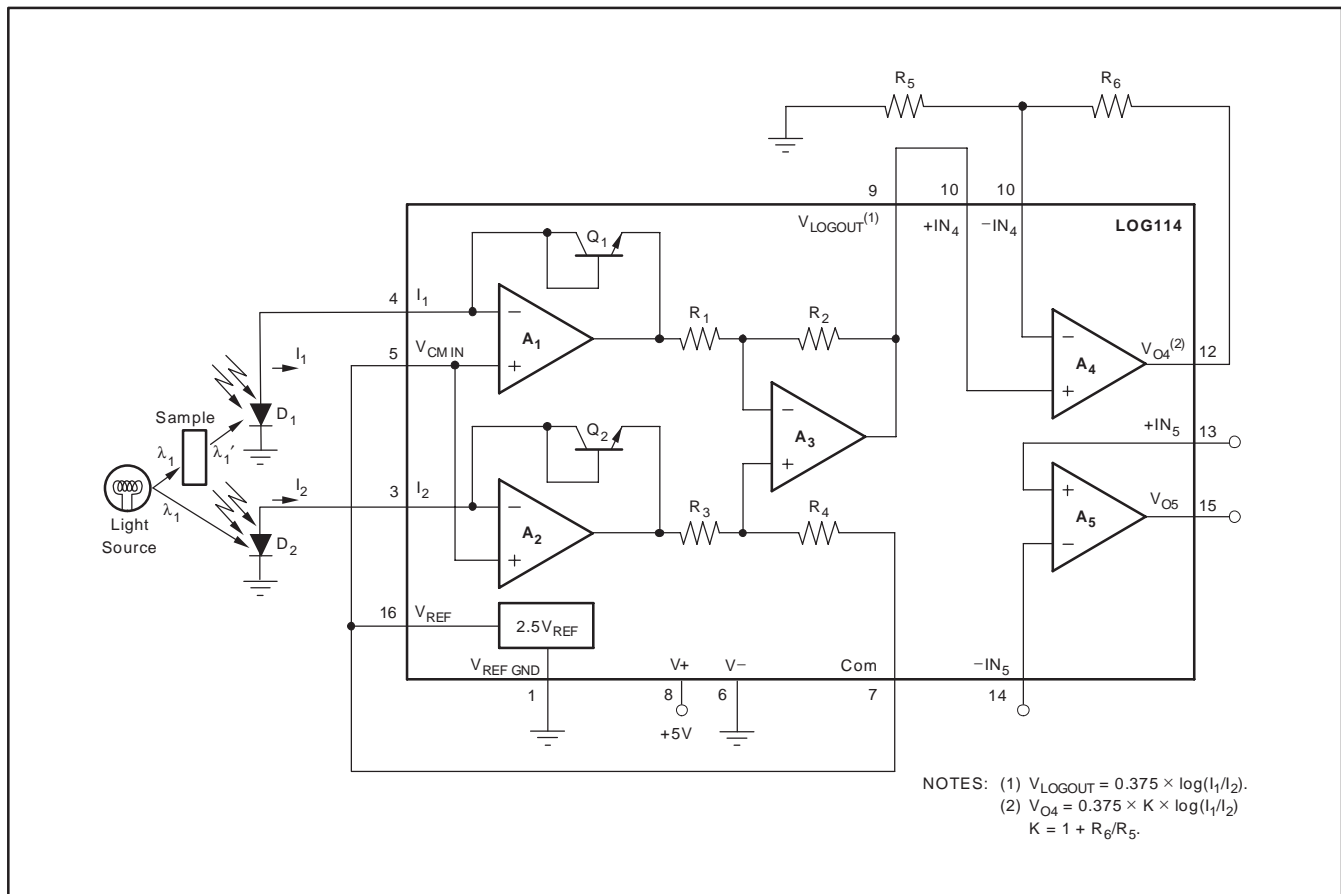

Figure 10. Using the LOG114 to Measure Absorbance.

DATA COMPRESSION

In many applications, the compressive effects of the logarithmic transfer function are useful. For example, a LOG114 preceding a 12-bit ADC can produce the dynamic range equivalent to a 20-bit converter. (Suggested products: ADS7818, ADS7834).

+3.3V OPERATION

For systems with only a +3.3V power supply, the TPS60241 zero-ripple switched cap buck-boost 2.7V to 5.5V input to 5V output converter may be used to generate a +5V supply for the LOG114, as shown in Figure 11.

Likewise, the TPS6040 negative charge pump may be connected to the +5V output of the TPS60241 to generate a -5V supply to create a $\pm 5V$ supply for the LOG114, as Figure 12 illustrates.

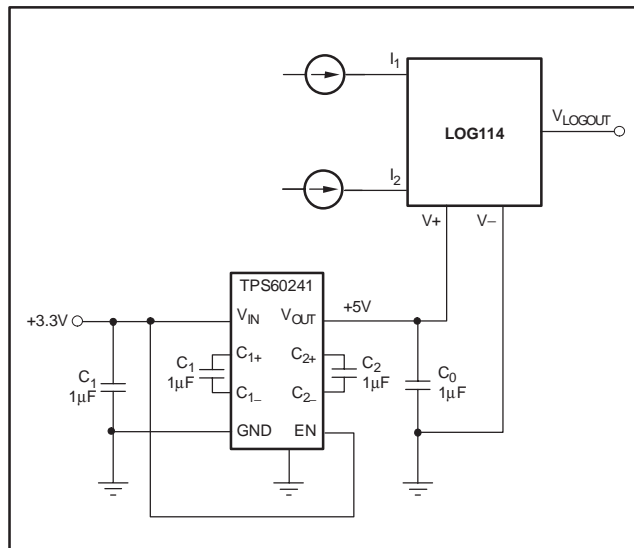

Figure 11. Creating a +5V Supply from a +3.3V Supply.

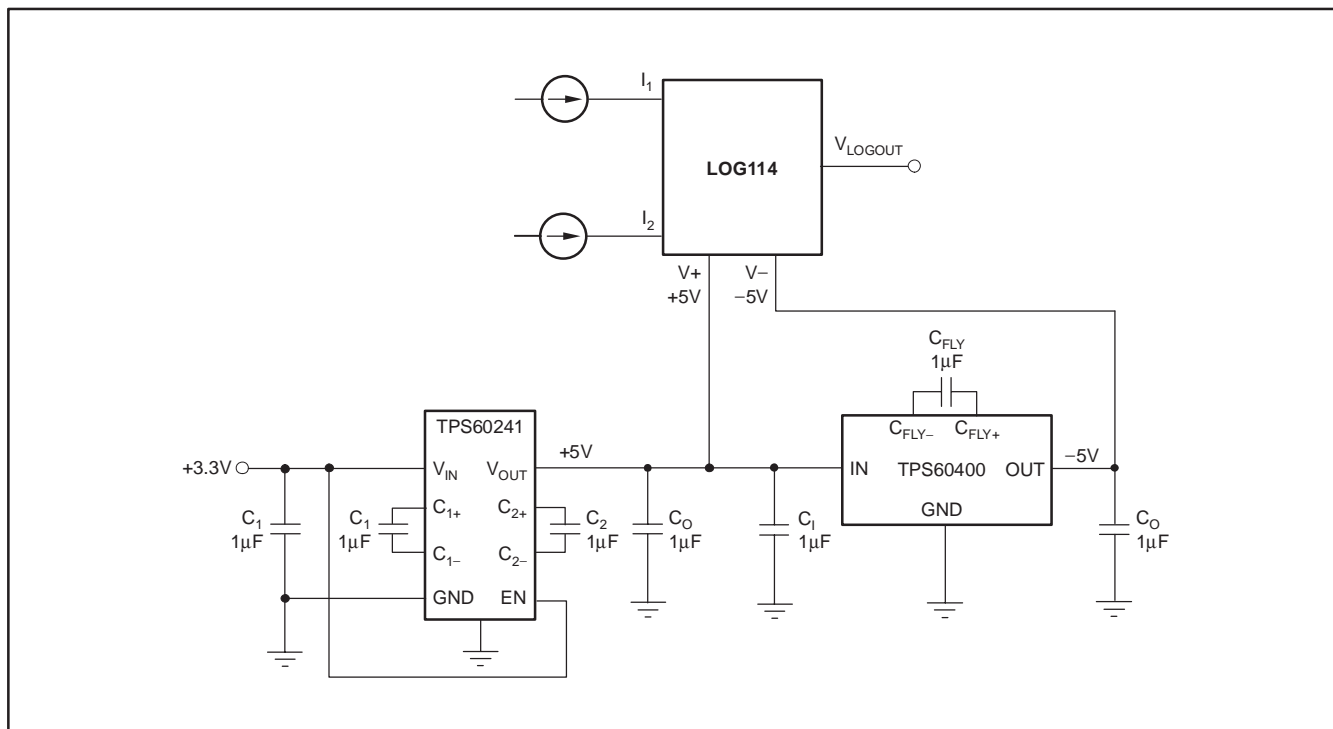

Figure 12. Creating a $\pm 5V$ Supply from a +3.3V Supply.

ERBIUM-DOPED FIBER OPTIC AMPLIFIER (EDFA)

The LOG114 was designed for optical networking systems. Figure 13 shows a block diagram of the LOG114 in a typical EDFA application. This application uses two log amps to measure the optical input and output power of the amplifier. A difference amplifier subtracts the log output signals of both log amps and applies an error voltage to the proportional-integral-derivative (PID) controller. The controller output adjusts a voltage-controlled current source (V_{CCS}), which then drives the power op amp and pump laser. The desired optical gain is achieved when the error voltage at the PID is zero.

The log ratio function is the optical power gain of the EDFA. This circuitry forms an automatic power level control loop.

An alternate design of the system shown in Figure 13 is possible because the LOG114 inherently takes the log ratio. Therefore, one log amp can be eliminated by connecting one of the photodiodes to the LOG114 I_1 input, and the other to the I_2 input. The differential amplifier would then be eliminated.

The LOG114 is uniquely suited for most EDFA applications because of its fast rise and fall times (typically less than $1\mu\text{s}$ for a 100:1 current input step). It also measures a very wide dynamic range of up to eight decades.

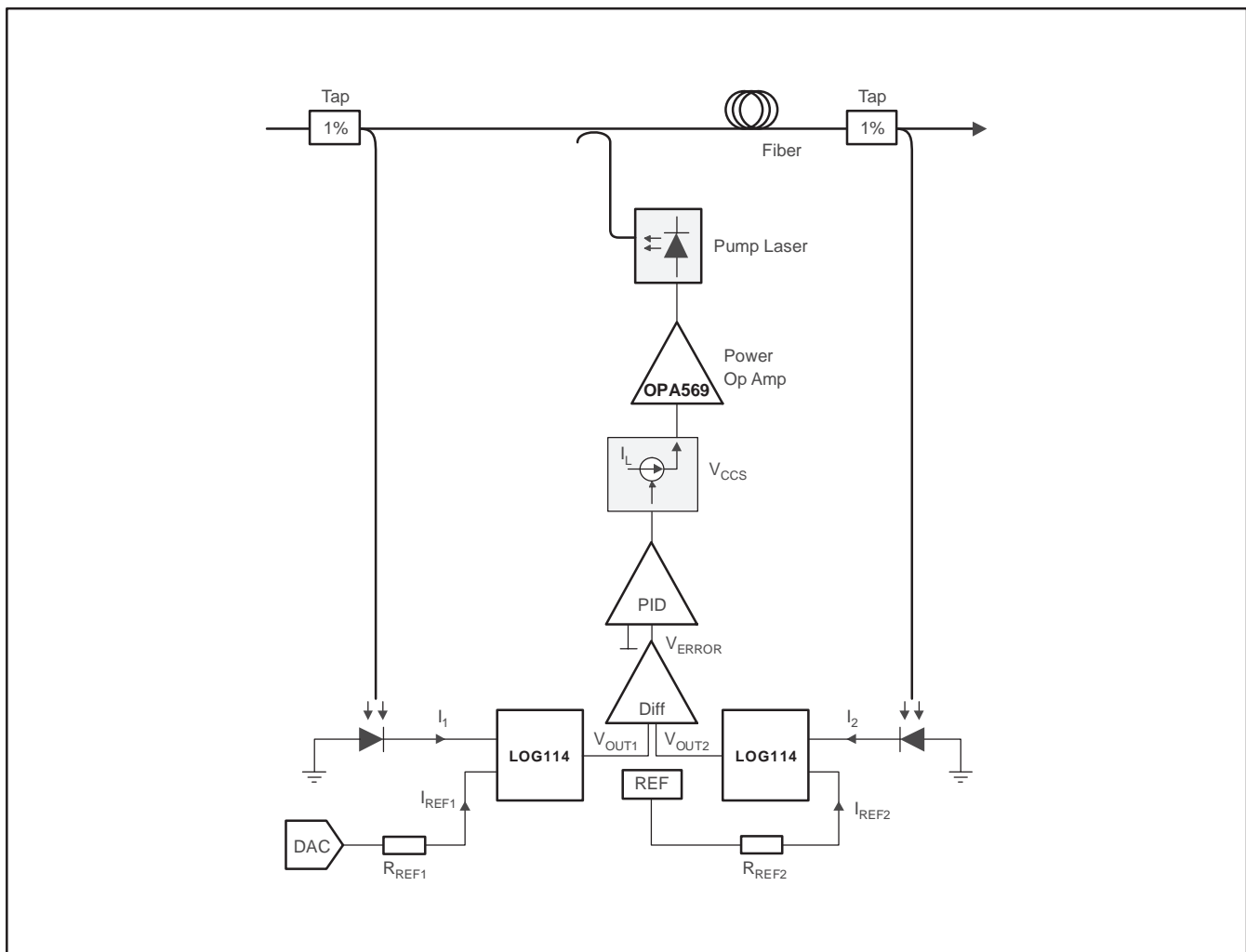

Figure 13. Erbium-Doped Fiber Optic Amplifier (EDFA) block diagram.

INSIDE THE LOG114

The LOG114 uses two matched logarithmic amplifiers (A_1 and A_2 with logging diodes in the feedback loops) to generate the outputs $\log(I_1)$ and $\log(I_2)$, respectively. The gain of 6.25 differential amplifier (A_3) subtracts the output of A_2 from the output of A_1 , resulting in $[\log(I_1) - \log(I_2)]$, or $\log(I_1/I_2)$. The symmetrical design of the A_1 and A_2 logarithmic amps allows I_1 and I_2 to be used interchangeably, and provides good bandwidth and phase characteristics with frequency.

DEFINITION OF TERMS

Transfer Function

The ideal transfer function of the LOG114 is:

$$V_{\text{LOGOUT}} = 0.375 \times \log\left(\frac{I_1}{I_2}\right) \quad (17)$$

This transfer function can be seen graphically in the typical characteristic curve, V_{LOGOUT} vs I_{REF} .

When a pedestal, or offset, voltage (V_{Com}) is connected to the Com pin, an additional offset term is introduced into the equation:

$$V_{\text{LOGOUT}} = 0.375 \times \log\left(\frac{I_1}{I_2}\right) + V_{\text{Com}} \quad (18)$$

Accuracy

Accuracy considerations for a log ratio amplifier are somewhat more complicated than for other amplifiers. This complexity exists because the transfer function is nonlinear and has two inputs, each of which can vary over a wide dynamic range. The accuracy for any combination of inputs is determined from the total error specification.

Total Error

The total error is the deviation of the actual output from the ideal output. Thus,

$$V_{\text{LOGOUT(ACTUAL)}} = V_{\text{LOGOUT(IDEAL)}} \pm \text{Total Error}$$

It represents the sum of all the individual components of error normally associated with the log amp when operating in the current input mode. The worst-case error for any given ratio of I_1/I_2 is the largest of the two errors when I_1 and I_2 are considered separately. Temperature can also affect total error.

Errors RTO and RTI

As with any transfer function, errors generated by the function may be Referred-to-Output (RTO) or Referred-to-Input (RTI). In this respect, log amps have a unique property: given some error voltage at the log amp output, that error corresponds to a constant percent of the input, regardless of the actual input level.

Log Conformity

For the LOG114, log conformity is calculated in the same way as linearity and is plotted as I_1/I_2 on a semi-log scale. In many applications, log conformity is the most important specification. This condition is true because bias current errors are negligible (5pA for the LOG114), and the scale factor and offset errors may be trimmed to zero or removed by system calibration. These factors leave log conformity as the major source of error.

Log conformity is defined as the peak deviation from the best fit straight line of the V_{LOGOUT} versus $\log(I_1/I_2)$ curve. Log conformity is then expressed as a percent of ideal full-scale output. Thus, the nonlinearity error expressed in volts over m decades is:

$$V_{\text{LOGOUT(NONLIN)}} = 0.375\text{V/decade} \cdot 2Nm$$

where N is the log conformity error, in percent.

INDIVIDUAL ERROR COMPONENTS

The ideal transfer function with current input is:

$$V_{\text{LOGOUT IDEAL}} = 0.375 \times \log\left(\frac{I_1}{I_2}\right) \quad (19)$$

The actual transfer function with the major components of error is:

$$0.375(1 \pm \Delta K) \times \log\left(\frac{I_1}{I_2}\right) \pm 2Nm \pm V_{\text{OSO}} \quad (20)$$

where:

ΔK = gain error (0.4%, typ, as specified in the *Electrical Characteristics* table)

I_{B1} = bias current of A_1 (5pA, typ)

I_{B2} = bias current of A_2 (5pA, typ)

m = number of decades over which the log conformity error is specified

N = log conformity error (0.1%, typ for $m = 5$ decades; 0.9% typ for $m = 7.5$ decades)

V_{OSO} = output offset voltage (11mV, typ for $\pm 5\text{V}$ supplies; 14mV, typ for +5V supplies)

To determine the typical error resulting from these error components, first compute the ideal output. Then calculate the output again, this time including the individual error components. Then determine the error in percent using Equation (21):

$$\% \text{error} = \frac{|V_{\text{LOGOUT IDEAL}} - V_{\text{LOGOUT TYP}}|}{V_{\text{LOGOUT IDEAL}}} \times 100\% \quad (21)$$

For example, in a system configured for measurement of five decades, with $I_1 = 1\text{mA}$, and $I_2 = 10\mu\text{A}$:

$$V_{\text{LOGOUT IDEAL}} = 0.375 \times \log\left(\frac{10^{-3}}{10^{-5}}\right) = 0.75\text{V} \quad (22)$$

$$V_{\text{LOGOUT TYP}} = 0.375(1 \pm 0.004) \times \log\left(\frac{10^{-3-5} \times 10^{-12}}{10^{-5-5} \times 10^{-12}}\right) \pm 2(0.001)(5) \pm 0.011 \quad (23)$$

Using the positive error components (+ ΔK , +2Nm, and + V_{OSO}) to calculate the maximum typical output:

$$V_{\text{LOGOUT TYP}} = 0.774\text{V} \quad (24)$$

Therefore, the error in percent is:

$$\% \text{error} = \frac{|0.75 - 0.774|}{0.75} \times 100\% = 3.2\% \quad (25)$$

QFN PACKAGE

The LOG114 comes in a QFN-16 package. This leadless package has lead contacts on all four sides of the bottom of the package, thereby maximizing board space. An exposed leadframe die pad on the bottom of the package enhances thermal and electrical characteristics.

QFN packages are physically small, have a smaller routing area, improved thermal performance, and improved electrical parasitics. Additionally, the absence of external leads eliminates bent-lead issues.

The QFN package can be easily mounted using standard printed circuit board (PCB) assembly techniques. See Application Note *QFN/SON PCB Attachment* (SLUA271) and Application Report *Quad Flatpack No-Lead Logic Packages* (SCBA017), both available for download at www.ti.com.

The exposed leadframe die pad on the bottom of the package should be connected to V–.

QFN LAYOUT GUIDELINES

The exposed leadframe die pad on the QFN package should be soldered to a thermal pad on the PCB. A mechanical drawing showing an example layout is attached at the end of this data sheet. Refinements to this layout may be necessary based on assembly process requirements. Mechanical drawings located at the end of this data sheet list the physical dimensions for the package and pad. The five holes in the landing pattern are optional, and are intended for use with thermal vias that connect the leadframe die pad to the heatsink area on the PCB.

Soldering the exposed pad significantly improves board-level reliability during temperature cycling, key push, package shear, and similar board-level tests. Even with applications that have low-power dissipation, the exposed pad must be soldered to the PCB to provide structural integrity and long-term reliability.

PACKAGING INFORMATION

Orderable Device	Status (1)	Package Type	Package Drawing	Pins	Package Qty	Eco Plan (2)	Lead/Ball Finish (6)	MSL Peak Temp (3)	Op Temp (°C)	Device Marking (4/5)	Samples
LOG114AIRGVR	ACTIVE	VQFN	RGV	16	1	Green (RoHS & no Sb/Br)	CU NIPDAU	Level-2-260C-1 YEAR	0 to 70	LOG 114	Samples
LOG114AIRGVRG4	ACTIVE	VQFN	RGV	16	1	Green (RoHS & no Sb/Br)	CU NIPDAU	Level-2-260C-1 YEAR	0 to 70	LOG 114	Samples
LOG114AIRGVT	ACTIVE	VQFN	RGV	16	250	Green (RoHS & no Sb/Br)	CU NIPDAU	Level-2-260C-1 YEAR	0 to 70	LOG 114	Samples
LOG114AIRGVTG4	ACTIVE	VQFN	RGV	16	250	Green (RoHS & no Sb/Br)	CU NIPDAU	Level-2-260C-1 YEAR	0 to 70	LOG 114	Samples

(1) The marketing status values are defined as follows:

ACTIVE: Product device recommended for new designs.

LIFEBUY: TI has announced that the device will be discontinued, and a lifetime-buy period is in effect.

NRND: Not recommended for new designs. Device is in production to support existing customers, but TI does not recommend using this part in a new design.

PREVIEW: Device has been announced but is not in production. Samples may or may not be available.

OBsolete: TI has discontinued the production of the device.

(2) **RoHS:** TI defines "RoHS" to mean semiconductor products that are compliant with the current EU RoHS requirements for all 10 RoHS substances, including the requirement that RoHS substance do not exceed 0.1% by weight in homogeneous materials. Where designed to be soldered at high temperatures, "RoHS" products are suitable for use in specified lead-free processes. TI may reference these types of products as "Pb-Free".

RoHS Exempt: TI defines "RoHS Exempt" to mean products that contain lead but are compliant with EU RoHS pursuant to a specific EU RoHS exemption.

Green: TI defines "Green" to mean the content of Chlorine (Cl) and Bromine (Br) based flame retardants meet JS709B low halogen requirements of <=1000ppm threshold. Antimony trioxide based flame retardants must also meet the <=1000ppm threshold requirement.

(3) MSL, Peak Temp. - The Moisture Sensitivity Level rating according to the JEDEC industry standard classifications, and peak solder temperature.

(4) There may be additional marking, which relates to the logo, the lot trace code information, or the environmental category on the device.

(5) Multiple Device Markings will be inside parentheses. Only one Device Marking contained in parentheses and separated by a "-" will appear on a device. If a line is indented then it is a continuation of the previous line and the two combined represent the entire Device Marking for that device.

(6) Lead/Ball Finish - Orderable Devices may have multiple material finish options. Finish options are separated by a vertical ruled line. Lead/Ball Finish values may wrap to two lines if the finish value exceeds the maximum column width.

Important Information and Disclaimer:The information provided on this page represents TI's knowledge and belief as of the date that it is provided. TI bases its knowledge and belief on information provided by third parties, and makes no representation or warranty as to the accuracy of such information. Efforts are underway to better integrate information from third parties. TI has taken and

continues to take reasonable steps to provide representative and accurate information but may not have conducted destructive testing or chemical analysis on incoming materials and chemicals. TI and TI suppliers consider certain information to be proprietary, and thus CAS numbers and other limited information may not be available for release.

In no event shall TI's liability arising out of such information exceed the total purchase price of the TI part(s) at issue in this document sold by TI to Customer on an annual basis.

TAPE AND REEL INFORMATION



QUADRANT ASSIGNMENTS FOR PIN 1 ORIENTATION IN TAPE



*All dimensions are nominal

Device	Package Type	Package Drawing	Pins	SPQ	Reel Diameter (mm)	Reel Width W1 (mm)	A0 (mm)	B0 (mm)	K0 (mm)	P1 (mm)	W (mm)	Pin1 Quadrant
LOG114AIRGVR	VQFN	RGV	16	2500	330.0	12.4	4.25	4.25	1.15	8.0	12.0	Q2
LOG114AIRGVT	VQFN	RGV	16	250	180.0	12.4	4.25	4.25	1.15	8.0	12.0	Q2

TAPE AND REEL BOX DIMENSIONS

*All dimensions are nominal

Device	Package Type	Package Drawing	Pins	SPQ	Length (mm)	Width (mm)	Height (mm)
LOG114AIRGVR	VQFN	RGV	16	2500	367.0	367.0	35.0
LOG114AIRGVT	VQFN	RGV	16	250	210.0	185.0	35.0

RGV (S-PVQFN-N16)

PLASTIC QUAD FLATPACK NO-LEAD

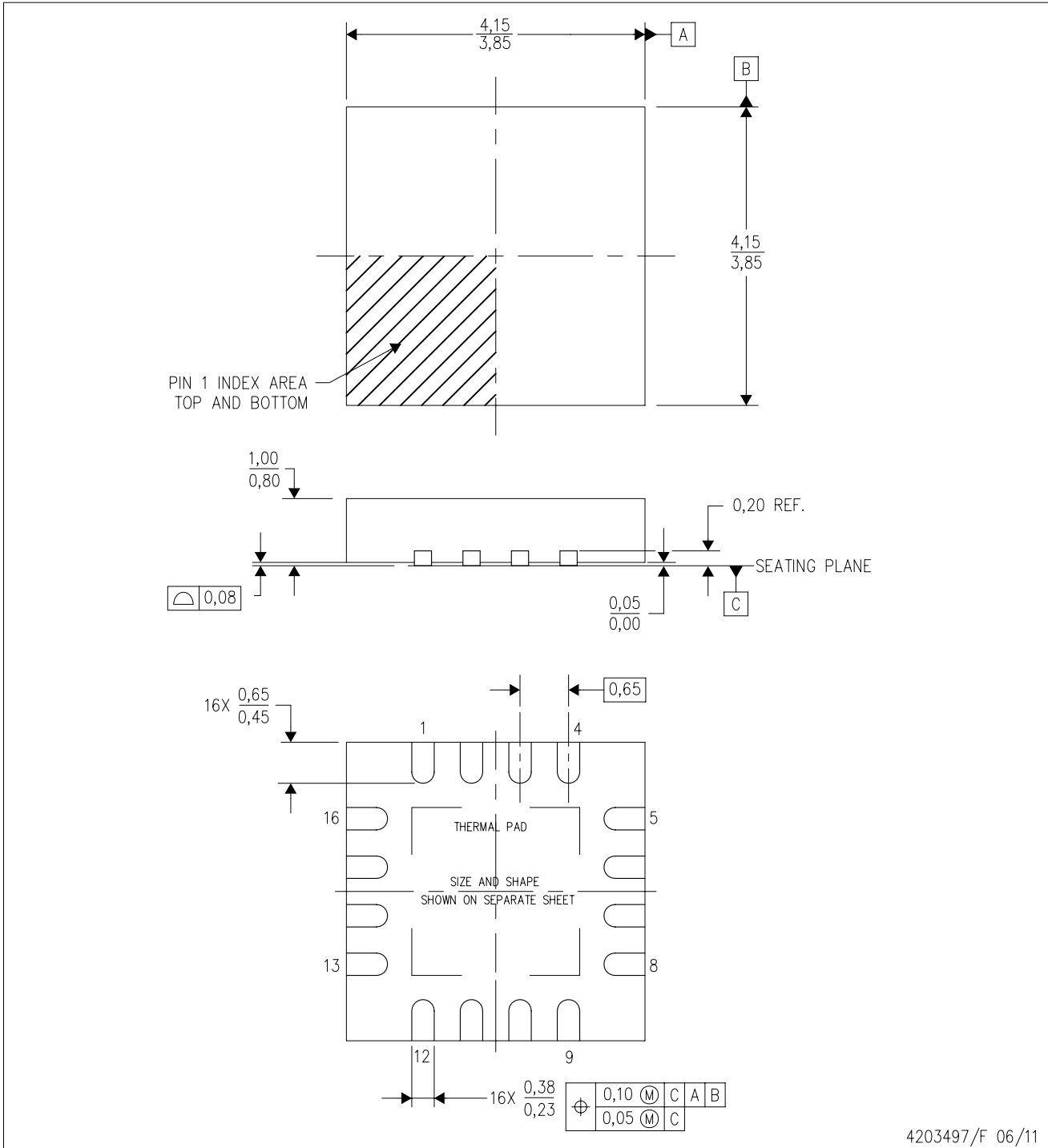

4203497/F 06/11

- NOTES:
- A. All linear dimensions are in millimeters. Dimensioning and tolerancing per ASME Y14.5M-1994.
 - B. This drawing is subject to change without notice.
 - C. Quad Flatpack, No-leads (QFN) package configuration.
 - D. The package thermal pad must be soldered to the board for thermal and mechanical performance.
 - E. See the additional figure in the Product Data Sheet for details regarding the exposed thermal pad features and dimensions.
 - F. Falls within JEDEC MO-220.

THERMAL PAD MECHANICAL DATA

RGV (S-PVQFN-N16)

PLASTIC QUAD FLATPACK NO-LEAD

THERMAL INFORMATION

This package incorporates an exposed thermal pad that is designed to be attached directly to an external heatsink. The thermal pad must be soldered directly to the printed circuit board (PCB). After soldering, the PCB can be used as a heatsink. In addition, through the use of thermal vias, the thermal pad can be attached directly to the appropriate copper plane shown in the electrical schematic for the device, or alternatively, can be attached to a special heatsink structure designed into the PCB. This design optimizes the heat transfer from the integrated circuit (IC).

For information on the Quad Flatpack No-Lead (QFN) package and its advantages, refer to Application Report, QFN/SON PCB Attachment, Texas Instruments Literature No. SLUA271. This document is available at www.ti.com.

The exposed thermal pad dimensions for this package are shown in the following illustration.

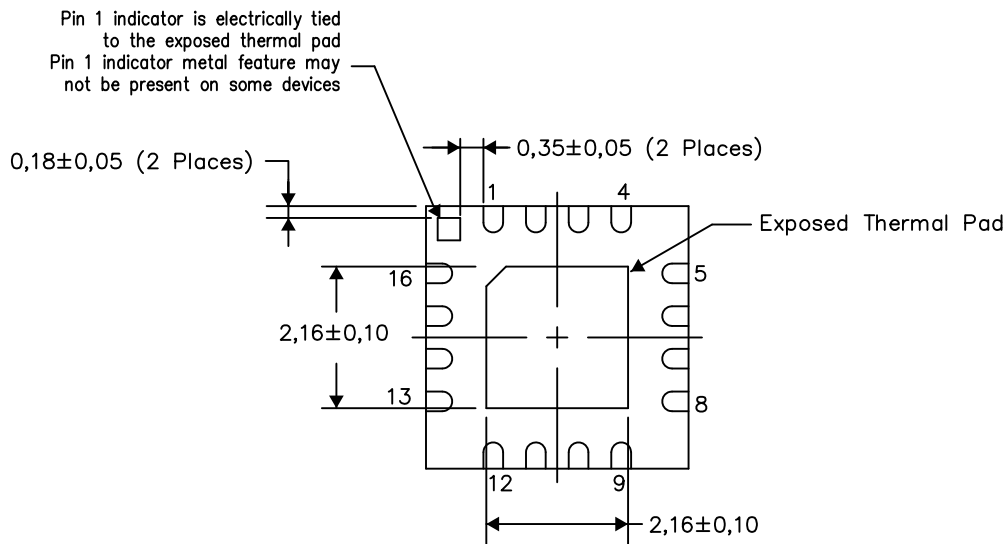

Bottom View

Exposed Thermal Pad Dimensions

4206351-2/L 05/13

NOTE: All linear dimensions are in millimeters

RGV (S-PVQFN-N16)

PLASTIC QUAD FLATPACK NO-LEAD

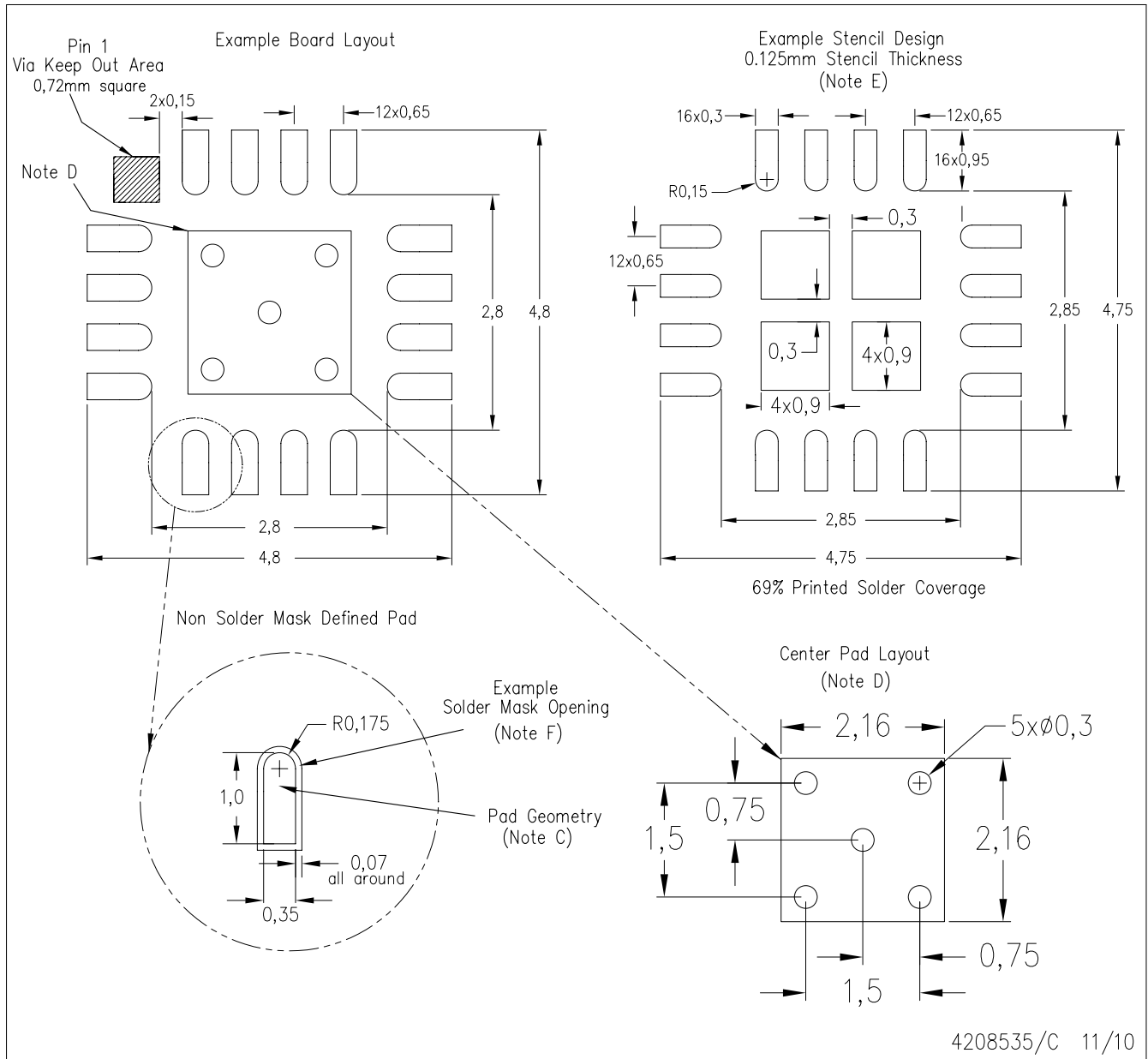

- NOTES: A. All linear dimensions are in millimeters.
 B. This drawing is subject to change without notice.
 C. Publication IPC-7351 is recommended for alternate designs.
 D. This package is designed to be soldered to a thermal pad on the board. Refer to Application Note, QFN Packages, Texas Instruments Literature No. SLUA271, and also the Product Data Sheets for specific thermal information, via requirements, and recommended board layout. These documents are available at www.ti.com <<http://www.ti.com>>.
 E. Laser cutting apertures with trapezoidal walls and also rounding corners will offer better paste release. Customers should contact their board assembly site for stencil design recommendations. Refer to IPC 7525 for stencil design considerations.
 F. Customers should contact their board fabrication site for solder mask tolerances.

IMPORTANT NOTICE

Texas Instruments Incorporated (TI) reserves the right to make corrections, enhancements, improvements and other changes to its semiconductor products and services per JESD46, latest issue, and to discontinue any product or service per JESD48, latest issue. Buyers should obtain the latest relevant information before placing orders and should verify that such information is current and complete.

TI's published terms of sale for semiconductor products (<http://www.ti.com/sc/docs/stdterms.htm>) apply to the sale of packaged integrated circuit products that TI has qualified and released to market. Additional terms may apply to the use or sale of other types of TI products and services.

Reproduction of significant portions of TI information in TI data sheets is permissible only if reproduction is without alteration and is accompanied by all associated warranties, conditions, limitations, and notices. TI is not responsible or liable for such reproduced documentation. Information of third parties may be subject to additional restrictions. Resale of TI products or services with statements different from or beyond the parameters stated by TI for that product or service voids all express and any implied warranties for the associated TI product or service and is an unfair and deceptive business practice. TI is not responsible or liable for any such statements.

Buyers and others who are developing systems that incorporate TI products (collectively, "Designers") understand and agree that Designers remain responsible for using their independent analysis, evaluation and judgment in designing their applications and that Designers have full and exclusive responsibility to assure the safety of Designers' applications and compliance of their applications (and of all TI products used in or for Designers' applications) with all applicable regulations, laws and other applicable requirements. Designer represents that, with respect to their applications, Designer has all the necessary expertise to create and implement safeguards that (1) anticipate dangerous consequences of failures, (2) monitor failures and their consequences, and (3) lessen the likelihood of failures that might cause harm and take appropriate actions. Designer agrees that prior to using or distributing any applications that include TI products, Designer will thoroughly test such applications and the functionality of such TI products as used in such applications.

TI's provision of technical, application or other design advice, quality characterization, reliability data or other services or information, including, but not limited to, reference designs and materials relating to evaluation modules, (collectively, "TI Resources") are intended to assist designers who are developing applications that incorporate TI products; by downloading, accessing or using TI Resources in any way, Designer (individually or, if Designer is acting on behalf of a company, Designer's company) agrees to use any particular TI Resource solely for this purpose and subject to the terms of this Notice.

TI's provision of TI Resources does not expand or otherwise alter TI's applicable published warranties or warranty disclaimers for TI products, and no additional obligations or liabilities arise from TI providing such TI Resources. TI reserves the right to make corrections, enhancements, improvements and other changes to its TI Resources. TI has not conducted any testing other than that specifically described in the published documentation for a particular TI Resource.

Designer is authorized to use, copy and modify any individual TI Resource only in connection with the development of applications that include the TI product(s) identified in such TI Resource. NO OTHER LICENSE, EXPRESS OR IMPLIED, BY ESTOPPEL OR OTHERWISE TO ANY OTHER TI INTELLECTUAL PROPERTY RIGHT, AND NO LICENSE TO ANY TECHNOLOGY OR INTELLECTUAL PROPERTY RIGHT OF TI OR ANY THIRD PARTY IS GRANTED HEREIN, including but not limited to any patent right, copyright, mask work right, or other intellectual property right relating to any combination, machine, or process in which TI products or services are used. Information regarding or referencing third-party products or services does not constitute a license to use such products or services, or a warranty or endorsement thereof. Use of TI Resources may require a license from a third party under the patents or other intellectual property of the third party, or a license from TI under the patents or other intellectual property of TI.

TI RESOURCES ARE PROVIDED "AS IS" AND WITH ALL FAULTS. TI DISCLAIMS ALL OTHER WARRANTIES OR REPRESENTATIONS, EXPRESS OR IMPLIED, REGARDING RESOURCES OR USE THEREOF, INCLUDING BUT NOT LIMITED TO ACCURACY OR COMPLETENESS, TITLE, ANY EPIDEMIC FAILURE WARRANTY AND ANY IMPLIED WARRANTIES OF MERCHANTABILITY, FITNESS FOR A PARTICULAR PURPOSE, AND NON-INFRINGEMENT OF ANY THIRD PARTY INTELLECTUAL PROPERTY RIGHTS. TI SHALL NOT BE LIABLE FOR AND SHALL NOT DEFEND OR INDEMNIFY DESIGNER AGAINST ANY CLAIM, INCLUDING BUT NOT LIMITED TO ANY INFRINGEMENT CLAIM THAT RELATES TO OR IS BASED ON ANY COMBINATION OF PRODUCTS EVEN IF DESCRIBED IN TI RESOURCES OR OTHERWISE. IN NO EVENT SHALL TI BE LIABLE FOR ANY ACTUAL, DIRECT, SPECIAL, COLLATERAL, INDIRECT, PUNITIVE, INCIDENTAL, CONSEQUENTIAL OR EXEMPLARY DAMAGES IN CONNECTION WITH OR ARISING OUT OF TI RESOURCES OR USE THEREOF, AND REGARDLESS OF WHETHER TI HAS BEEN ADVISED OF THE POSSIBILITY OF SUCH DAMAGES.

Unless TI has explicitly designated an individual product as meeting the requirements of a particular industry standard (e.g., ISO/TS 16949 and ISO 26262), TI is not responsible for any failure to meet such industry standard requirements.

Where TI specifically promotes products as facilitating functional safety or as compliant with industry functional safety standards, such products are intended to help enable customers to design and create their own applications that meet applicable functional safety standards and requirements. Using products in an application does not by itself establish any safety features in the application. Designers must ensure compliance with safety-related requirements and standards applicable to their applications. Designer may not use any TI products in life-critical medical equipment unless authorized officers of the parties have executed a special contract specifically governing such use. Life-critical medical equipment is medical equipment where failure of such equipment would cause serious bodily injury or death (e.g., life support, pacemakers, defibrillators, heart pumps, neurostimulators, and implantables). Such equipment includes, without limitation, all medical devices identified by the U.S. Food and Drug Administration as Class III devices and equivalent classifications outside the U.S.

TI may expressly designate certain products as completing a particular qualification (e.g., Q100, Military Grade, or Enhanced Product). Designers agree that it has the necessary expertise to select the product with the appropriate qualification designation for their applications and that proper product selection is at Designers' own risk. Designers are solely responsible for compliance with all legal and regulatory requirements in connection with such selection.

Designer will fully indemnify TI and its representatives against any damages, costs, losses, and/or liabilities arising out of Designer's non-compliance with the terms and provisions of this Notice.