

# LMK00308 3-GHz 8-Output Ultra-Low Additive Jitter Differential Clock Buffer/Level Translator

## 1 Features

- 3:1 Input Multiplexer:
  - Two Universal Inputs Operate up to 3.1 GHz and Accept LVPECL, LVDS, CML, SSTL, HSTL, HCSL, or Single-Ended Clocks
  - One Crystal Input Accepts a 10 to 40 MHz Crystal or Single-Ended Clock
- Two Banks with 4 Differential Outputs Each:
  - LVPECL, LVDS, HCSL, or Hi-Z (Selectable Per Bank)
  - LVPECL Additive Jitter with LMK03806 Clock Source at 156.25 MHz:
    - 20 fs RMS (10 kHz to 1 MHz)
    - 51 fs RMS (12 kHz to 20 MHz)
- High PSRR: -65 / -76 dBc (LVPECL/LVDS) at 156.25 MHz
- LVC MOS Output with Synchronous Enable Input
- Pin-Controlled Configuration
- $V_{CC}$  Core Supply: 3.3 V  $\pm$  5%
- 3 Independent  $V_{CCO}$  Output Supplies: 3.3 V/2.5 V  $\pm$  5%
- Industrial Temperature Range: -40°C to +85°C
- 40-lead WQFN (6 mm  $\times$  6 mm)

## 2 Applications

- Clock Distribution and Level Translation for ADCs, DACs, Multi-Gigabit Ethernet, XAUI, Fibre Channel, SATA/SAS, SONET/SDH, CPRI, High-Frequency Backplanes
- Switches, Routers, Line Cards, Timing Cards
- Servers, Computing, PCI Express (PCIe 3.0)
- Remote Radio Units and Baseband Units

## 3 Description

The LMK00308 is a 3-GHz, 8-output differential fanout buffer intended for high-frequency, low-jitter clock/data distribution and level translation. The input clock can be selected from two universal inputs or one crystal input. The selected input clock is distributed to two banks of 4 differential outputs and one LVC MOS output. Both differential output banks can be independently configured as LVPECL, LVDS, or HCSL drivers, or disabled. The LVC MOS output has a synchronous enable input for runt-pulse-free operation when enabled or disabled. The LMK00308 operates from a 3.3 V core supply and 3 independent 3.3 V/2.5 V output supplies.

The LMK00308 provides high performance, versatility, and power efficiency, making it ideal for replacing fixed-output buffer devices while increasing timing margin in the system.

### Device Information<sup>(1)</sup>

PART NUMBER	PACKAGE	BODY SIZE (NOM)
LMK00308	WQFN (40)	6.00 mm $\times$ 6.00 mm

(1) For all available packages, see the orderable addendum at the end of the data sheet.

## 4 Functional Block Diagram

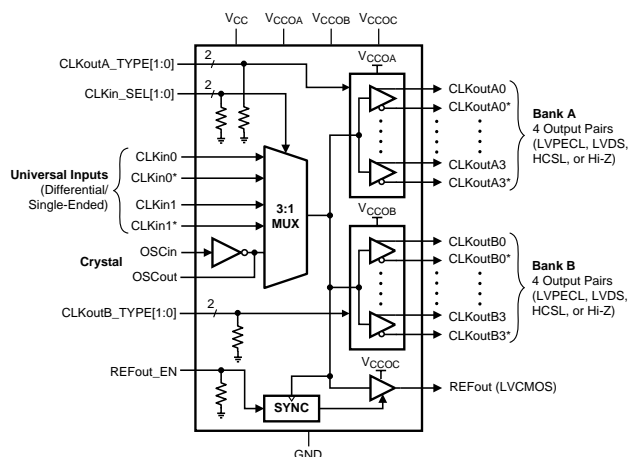

### LVPECL Output Swing ( $V_{OD}$ ) vs. Frequency

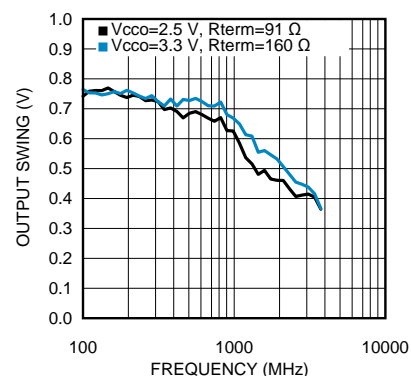

## Table of Contents

<b>1 Features</b> .....	1	9.3 Feature Description.....	20
<b>2 Applications</b> .....	1	<b>10 Application and Implementation</b> .....	22
<b>3 Description</b> .....	1	10.1 Driving the Clock Inputs .....	22
<b>4 Functional Block Diagram</b> .....	1	10.2 Crystal Interface.....	23
<b>5 Revision History</b> .....	2	10.3 Termination and Use of Clock Drivers .....	24
<b>6 Pin Configuration and Functions</b> .....	4	<b>11 Power Supply Recommendations</b> .....	29
<b>7 Specifications</b> .....	6	11.1 Power Supply Sequencing.....	29
7.1 Absolute Maximum Ratings .....	6	11.2 Current Consumption and Power Dissipation Calculations.....	29
7.2 ESD Ratings.....	6	11.3 Power Supply Bypassing .....	31
7.3 Recommended Operating Conditions .....	6	11.4 Thermal Management.....	32
7.4 Thermal Information .....	6	<b>12 Device and Documentation Support</b> .....	34
7.5 Electrical Characteristics.....	7	12.1 Documentation Support .....	34
7.6 Typical Characteristics.....	14	12.2 Community Resources.....	34
<b>8 Parameter Measurement Information</b> .....	18	12.3 Trademarks .....	34
8.1 Differential Voltage Measurement Terminology.....	18	12.4 Electrostatic Discharge Caution.....	34
<b>9 Detailed Description</b> .....	19	12.5 Glossary .....	34
9.1 Overview .....	19	<b>13 Mechanical, Packaging, and Orderable Information</b> .....	34
9.2 Functional Block Diagram .....	19		

## 5 Revision History

NOTE: Page numbers for previous revisions may differ from page numbers in the current version.

Changes from Revision C (May 2013) to Revision D	Page
• Added " Ultra-Low Additive Jitter" to document title .....	1
• Added, updated, or renamed the following sections: <i>Specifications; Detailed Description; Application and Implementation; Power Supply Recommendations; Device and Documentation Support; Mechanical, Packaging, and Ordering Information</i> .....	1
• Changed Cin (typ) from 1 pF to 4 pF (based on updated test method) in <i>Electrical Characteristics: Crystal Interface</i> .....	8
• Added footnote for $V_{LSE}$ parameter in the <i>Electrical Characteristics</i> table. ....	8
• Added "Additive RMS Jitter, Integration Bandwidth 10 kHz to 20 MHz" parameter with 100 MHz and 156.25 MHz Test conditions, Typical values, Max values, and footnotes in <i>Electrical Characteristics: LVPECL Outputs</i> .....	9
• Added "Additive RMS Jitter, Integration Bandwidth 10 kHz to 20 MHz" parameter with 100 MHz and 156.25 MHz Test conditions, Typical values, Max values, and footnotes in <i>Electrical Characteristics: LVDS Outputs</i> .....	10
• Added new paragraph at end of <i>Driving the Clock Inputs</i> .....	22
• Changed part number in <a href="#">Figure 27</a> and <a href="#">Figure 28</a> to "LMK00308" .....	23
• Changed Cin = 4 pF (typ, based on updated test method) in <i>Crystal Interface</i> .....	23
• Added Power Supply Sequencing .....	29

Changes from Revision B (February 2013) to Revision C	Page
• Changed <i>Target Applications</i> by adding additional applications to the second and third bullets, and removing High-Speed and Serial Interfaces from first bullet. ....	1
• Changed $V_{CM}$ text to condition for $V_{IH}$ to $V_{CM}$ parameter group. ....	8
• Deleted $V_{IH}$ min value from <i>Electrical Characteristics</i> table. ....	8
• Deleted $V_{IL}$ max value from <i>Electrical Characteristics</i> table.....	8
• Added $V_{LSE}$ parameter and spec limits with corresponding table note to <i>Electrical Characteristics</i> Table. ....	8
• Changed third paragraph in <i>Driving the Clock Inputs</i> section to include CLKin* and LVCMOS text. Revised to better correspond with information in <i>Electrical Characteristics</i> Table .....	22
• Changed bypass cap text to signal attenuation text of the fourth paragraph in <i>Driving the Clock Inputs</i> section. ....	22

- 
- Changed *Single-Ended LVCMOS Input, DC Coupling with Common Mode Biasing* image with revised graphic..... 23
  - Added text to second paragraph of *Termination for AC Coupled Differential Operation* to explain graphic update to *Differential LVDS Operation with AC Coupling to Receivers*. ..... 26
  - Changed graphic for *Differential LVDS Operation, AC Coupling, No Biasing by the Receiver* and updated caption. .... 26
-

## 6 Pin Configuration and Functions

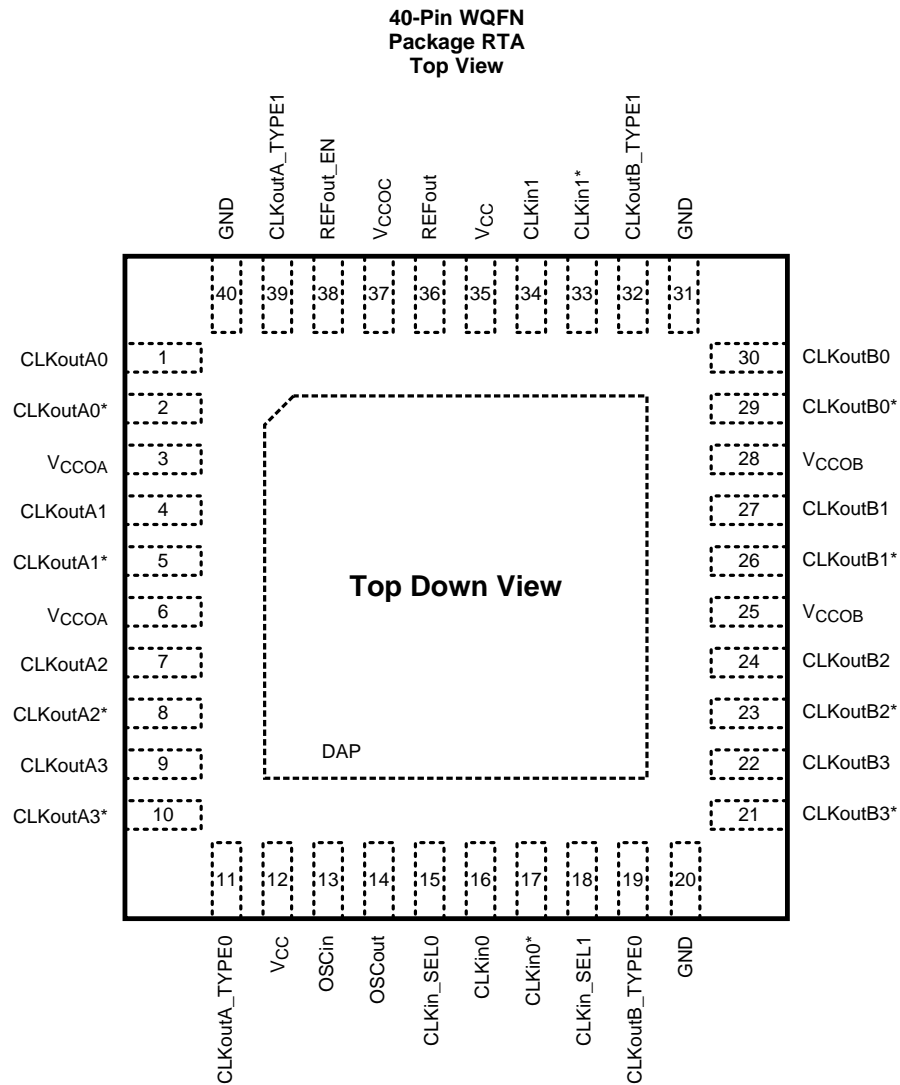

**Pin Functions<sup>(1)</sup>**

PIN		TYPE	DESCRIPTION
NO.	NAME		
DAP	DAP	GND	Die Attach Pad. Connect to the PCB ground plane for heat dissipation.
1, 2	CLKoutA0, CLKoutA0*	O	Differential clock output A0. Output type set by CLKoutA_TYPE pins.
3, 6	V <sub>CCOA</sub>	PWR	Power supply for Bank A Output buffers. V <sub>CCOA</sub> can operate from 3.3 V or 2.5 V. The V <sub>CCOA</sub> pins are internally tied together. Bypass with a 0.1 uF low-ESR capacitor placed very close to each V <sub>cco</sub> pin. <sup>(2)</sup>
4, 5	CLKoutA1, CLKoutA1*	O	Differential clock output A1. Output type set by CLKoutA_TYPE pins.
7, 8	CLKoutA2, CLKoutA2*	O	Differential clock output A2. Output type set by CLKoutA_TYPE pins.
9, 10	CLKoutA3, CLKoutA3*	O	Differential clock output A3. Output type set by CLKoutA_TYPE pins.
11, 39	CLKoutA_TYPE0, CLKoutA_TYPE1	I	Bank A output buffer type selection pins <sup>(3)</sup>
12, 35	V <sub>cc</sub>	PWR	Power supply for Core and Input buffer blocks. The V <sub>cc</sub> supply operates from 3.3 V. Bypass with a 0.1 uF low-ESR capacitor placed very close to each V <sub>cc</sub> pin.
13	OSCin	I	Input for crystal. Can also be driven by a XO, TCXO, or other external single-ended clock.
14	OSCOut	O	Output for crystal. Leave OSCout floating if OSCin is driven by a single-ended clock.
15, 18	CLKin_SEL0, CLKin_SEL1	I	Clock input selection pins <sup>(3)</sup>
16, 17	CLKin0, CLKin0*	I	Universal clock input 0 (differential/single-ended)
19, 32	CLKoutB_TYPE0, CLKoutB_TYPE1	I	Bank B output buffer type selection pins <sup>(3)</sup>
20, 31, 40	GND	GND	Ground
21, 22	CLKoutB3*, CLKoutB3	O	Differential clock output B3. Output type set by CLKoutB_TYPE pins.
23, 24	CLKoutB2*, CLKoutB2	O	Differential clock output B2. Output type set by CLKoutB_TYPE pins.
25, 28	V <sub>CCOB</sub>	PWR	Power supply for Bank B Output buffers. V <sub>CCOB</sub> can operate from 3.3 V or 2.5 V. The V <sub>CCOB</sub> pins are internally tied together. Bypass with a 0.1 uF low-ESR capacitor placed very close to each V <sub>cco</sub> pin. <sup>(2)</sup>
26, 27	CLKoutB1*, CLKoutB1	O	Differential clock output B1. Output type set by CLKoutB_TYPE pins.
29, 30	CLKoutB0*, CLKoutB0	O	Differential clock output B0. Output type set by CLKoutB_TYPE pins.
33, 34	CLKin1*, CLKin1	I	Universal clock input 1 (differential/single-ended)
36	REFout	O	LVC MOS reference output. Enable output by pulling REFout_EN pin high.
37	V <sub>CCOC</sub>	PWR	Power supply for REFout Output buffer. V <sub>CCOC</sub> can operate from 3.3 V or 2.5 V. Bypass with a 0.1 uF low-ESR capacitor placed very close to each V <sub>cco</sub> pin. <sup>(2)</sup>
38	REFout_EN	I	REFout enable input. Enable signal is internally synchronized to selected clock input. <sup>(3)</sup>

- (1) Any unused output pins should be left floating with minimum copper length (see note in [Clock Outputs](#)), or properly terminated if connected to a transmission line, or disabled/Hi-Z if possible. See [Clock Outputs](#) for output configuration or [Termination and Use of Clock Drivers](#) output interface and termination techniques.
- (2) The output supply voltages/pins (V<sub>CCOA</sub>, V<sub>CCOB</sub>, and V<sub>CCOC</sub>) will be referred to generally as V<sub>CCO</sub> when no distinction is needed, or when the output supply can be inferred by the output bank/type.
- (3) CMOS control input with internal pull-down resistor.

## 7 Specifications

### 7.1 Absolute Maximum Ratings

over operating free-air temperature range (unless otherwise noted) <sup>(1)(2)</sup>

		MIN	MAX	UNIT
V <sub>CC</sub> , V <sub>CCO</sub>	Supply voltages	-0.3	3.6	V
V <sub>IN</sub>	Input voltage	-0.3	(V <sub>CC</sub> + 0.3)	V
T <sub>STG</sub>	Storage temperature	-65	+150	°C
T <sub>L</sub>	Lead temperature (solder 4 s)		+260	°C
T <sub>J</sub>	Junction temperature		+150	°C

- (1) Stresses beyond those listed under *Absolute Maximum Ratings* may cause permanent damage to the device. These are stress ratings only, which do not imply functional operation of the device at these or any other conditions beyond those indicated under *Recommended Operating Conditions*. Exposure to absolute-maximum-rated conditions for extended periods may affect device reliability.
- (2) If Military/Aerospace specified devices are required, please contact the Texas Instruments Sales Office/Distributors for availability and specifications.

### 7.2 ESD Ratings

		VALUE	UNIT
V <sub>(ESD)</sub> <sup>(1)</sup>	Electrostatic discharge		
	Human-body model (HBM), per ANSI/ESDA/JEDEC JS-001 <sup>(2)</sup>	±2000	V
	Machine model (MM)	±150	
Charged-device model (CDM), per JEDEC specification JESD22-C101 <sup>(3)</sup>	±750		

- (1) Handling and assembly of this device should only be done at ESD-free workstations.
- (2) JEDEC document JEP155 states that 500-V HBM allows safe manufacturing with a standard ESD control process. Manufacturing with less than 500-V HBM is possible with the necessary precautions. Pins listed as ±2000 V may actually have higher performance.
- (3) JEDEC document JEP157 states that 250-V CDM allows safe manufacturing with a standard ESD control process. Manufacturing with less than 250-V CDM is possible with the necessary precautions. Pins listed as ±750 V may actually have higher performance.

### 7.3 Recommended Operating Conditions

		MIN	TYP	MAX	UNIT
T <sub>A</sub>	Ambient Temperature Range	-40	25	85	°C
T <sub>J</sub>	Junction Temperature			125	°C
V <sub>CC</sub>	Core Supply Voltage Range	3.15	3.3	3.45	V
V <sub>CCO</sub>	Output Supply Voltage Range <sup>(1) (2)</sup>	3.3 – 5% 2.5 – 5%	3.3 2.5	3.3 + 5% 2.5 + 5%	V

- (1) The output supply voltages/pins (V<sub>CCOA</sub>, V<sub>CCOB</sub>, and V<sub>CCOC</sub>) will be referred to generally as V<sub>CCO</sub> when no distinction is needed, or when the output supply can be inferred by the output bank/type.
- (2) V<sub>CCO</sub> should be less than or equal to V<sub>CC</sub> (V<sub>CCO</sub> ≤ V<sub>CC</sub>).

### 7.4 Thermal Information

THERMAL METRIC <sup>(1)(2)</sup>		LMK00308	UNIT
		RTA (WQFN)	
		40 PINS	
R <sub>θJA</sub>	Junction-to-ambient thermal resistance	31.4	°C/W
R <sub>θJC(top)</sub> (DAP)	Junction-to-case (top) thermal resistance	7.2	

- (1) For more information about traditional and new thermal metrics, see the *IC Package Thermal Metrics* application report, [SPRA953](#).
- (2) Specification assumes 9 thermal vias connect the die attach pad (DAP) to the embedded copper plane on the 4-layer JEDEC board. These vias play a key role in improving the thermal performance of the package. It is recommended that the maximum number of vias be used in the board layout.

## 7.5 Electrical Characteristics

Unless otherwise specified:  $V_{CC} = 3.3\text{ V} \pm 5\%$ ,  $V_{CCO} = 3.3\text{ V} \pm 5\%$ ,  $2.5\text{ V} \pm 5\%$ ,  $-40\text{ }^\circ\text{C} \leq T_A \leq 85\text{ }^\circ\text{C}$ , CLKin driven differentially, input slew rate  $\geq 3\text{ V/ns}$ . Typical values represent most likely parametric norms at  $V_{CC} = 3.3\text{ V}$ ,  $V_{CCO} = 3.3\text{ V}$ ,  $T_A = 25\text{ }^\circ\text{C}$ , and at the Recommended Operation Conditions at the time of product characterization and are not ensured. <sup>(1) (2)</sup>

PARAMETER		TEST CONDITIONS		MIN	TYP	MAX	UNIT
<b>CURRENT CONSUMPTION<sup>(3)</sup></b>							
$I_{CC\_CORE}$	Core Supply Current, All Outputs Disabled	CLKinX selected			8.5	10.5	mA
		OSCin selected			10	13.5	mA
$I_{CC\_PECL}$	Additive Core Supply Current, Per LVPECL Bank Enabled				20	26.5	mA
$I_{CC\_LVDS}$	Additive Core Supply Current, Per LVDS Bank Enabled				25	30.5	mA
$I_{CC\_HCSL}$	Additive Core Supply Current, Per HCSL Bank Enabled				31	38.5	mA
$I_{CC\_CMOS}$	Additive Core Supply Current, LVCMOS Output Enabled				3.5	5.5	mA
$I_{CCO\_PECL}$	Additive Output Supply Current, Per LVPECL Bank Enabled	Includes Output Bank Bias and Load Currents, $R_T = 50\ \Omega$ to $V_{CCO} - 2\text{V}$ on all outputs in bank			132	160	mA
$I_{CCO\_LVDS}$	Additive Output Supply Current, Per LVDS Bank Enabled				26	34.5	mA
$I_{CCO\_HCSL}$	Additive Output Supply Current, Per HCSL Bank Enabled	Includes Output Bank Bias and Load Currents, $R_T = 50\ \Omega$ on all outputs in bank			68	84	mA
$I_{CCO\_CMOS}$	Additive Output Supply Current, LVCMOS Output Enabled	200 MHz, $C_L = 5\text{ pF}$	$V_{CCO} = 3.3\text{ V} \pm 5\%$		9	10	mA
			$V_{CCO} = 2.5\text{ V} \pm 5\%$		7	8	mA
<b>POWER SUPPLY RIPPLE REJECTION (PSRR)</b>							
$PSRR_{PECL}$	Ripple-Induced Phase Spur Level Differential LVPECL Output <sup>(4)</sup>	100 kHz, 100 mVpp Ripple Injected on $V_{CCO}$ , $V_{CCO} = 2.5\text{ V}$	156.25 MHz		-65		dBc
			312.5 MHz		-63		
$PSRR_{LVDS}$	Ripple-Induced Phase Spur Level Differential LVDS Output <sup>(4)</sup>		156.25 MHz		-76		dBc
			312.5 MHz		-74		
$PSRR_{HCSL}$	Ripple-Induced Phase Spur Level Differential HCSL Output <sup>(4)</sup>		156.25 MHz		-72		dBc
			312.5 MHz		-63		
<b>CMOS CONTROL INPUTS (CLKin_SELn, CLKoutX_TYPEn, REFout_EN)</b>							
$V_{IH}$	High-Level Input Voltage			1.6		$V_{CC}$	V
$V_{IL}$	Low-Level Input Voltage			GND		0.4	V
$I_{IH}$	High-Level Input Current	$V_{IH} = V_{CC}$ , Internal pull-down resistor				50	$\mu\text{A}$
$I_{IL}$	Low-Level Input Current	$V_{IL} = 0\text{ V}$ , Internal pull-down resistor		-5	0.1		$\mu\text{A}$

- (1) The output supply voltages/pins ( $V_{CCOA}$ ,  $V_{CCOB}$ , and  $V_{CCOC}$ ) will be referred to generally as  $V_{CCO}$  when no distinction is needed, or when the output supply can be inferred by the output bank/type.
- (2) The Electrical Characteristics tables list ensured specifications under the listed Recommended Operating Conditions except as otherwise modified or specified by the Electrical Characteristics Conditions and/or Notes. Typical specifications are estimations only and are not ensured.
- (3) See [Power Supply Recommendations](#) for more information on current consumption and power dissipation calculations.
- (4) Power supply ripple rejection, or PSRR, is defined as the single-sideband phase spur level (in dBc) modulated onto the clock output when a single-tone sinusoidal signal (ripple) is injected onto the  $V_{CCO}$  supply. Assuming no amplitude modulation effects and small index modulation, the peak-to-peak deterministic jitter (DJ) can be calculated using the measured single-sideband phase spur level (PSRR) as follows:  $DJ\text{ (ps pk-pk)} = [(2 * 10^{(PSRR / 20)}) / (\pi * f_{CLK})] * 1E12$

## Electrical Characteristics (continued)

Unless otherwise specified:  $V_{CC} = 3.3 \text{ V} \pm 5\%$ ,  $V_{CC0} = 3.3 \text{ V} \pm 5\%$ ,  $2.5 \text{ V} \pm 5\%$ ,  $-40 \text{ }^\circ\text{C} \leq T_A \leq 85 \text{ }^\circ\text{C}$ , CLKin driven differentially, input slew rate  $\geq 3 \text{ V/ns}$ . Typical values represent most likely parametric norms at  $V_{CC} = 3.3 \text{ V}$ ,  $V_{CC0} = 3.3 \text{ V}$ ,  $T_A = 25 \text{ }^\circ\text{C}$ , and at the Recommended Operation Conditions at the time of product characterization and are not ensured. <sup>(1) (2)</sup>

PARAMETER		TEST CONDITIONS	MIN	TYP	MAX	UNIT
<b>CLOCK INPUTS (CLKin0/CLKin0*, CLKin1/CLKin1*)</b>						
$f_{\text{CLKin}}$	Input Frequency Range <sup>(5)</sup>	Functional up to 3.1 GHz Output frequency range and timing specified per output type (refer to LVPECL, LVDS, HCSSL, LVCMOS output specifications)	DC		3.1	GHz
$V_{\text{IHD}}$	Differential Input High Voltage	CLKin driven differentially			$V_{CC}$	V
$V_{\text{ILD}}$	Differential Input Low Voltage				GND	V
$V_{\text{ID}}$	Differential Input Voltage Swing <sup>(6)</sup>		0.15		1.3	V
$V_{\text{CMD}}$	Differential Input Common Mode Voltage	$V_{\text{ID}} = 150 \text{ mV}$	0.25		$V_{CC} - 1.2$	V
		$V_{\text{ID}} = 350 \text{ mV}$	0.25		$V_{CC} - 1.1$	
		$V_{\text{ID}} = 800 \text{ mV}$	0.25		$V_{CC} - 0.9$	
$V_{\text{IH}}$	Single-Ended Input High Voltage	CLKinX driven single-ended (AC or DC coupled), CLKinX* AC coupled to GND or externally biased within $V_{\text{CM}}$ range			$V_{CC}$	V
$V_{\text{IL}}$	Single-Ended Input Low Voltage				GND	V
$V_{\text{I,SE}}$	Single-Ended Input Voltage Swing <sup>(7)(8)</sup>		0.3		2	Vpp
$V_{\text{CM}}$	Single-Ended Input Common Mode Voltage		0.25		$V_{CC} - 1.2$	V
$\text{ISO}_{\text{MUX}}$	Mux Isolation, CLKin0 to CLKin1	$f_{\text{OFFSET}} > 50 \text{ kHz}$ , $P_{\text{CLKinX}} = 0 \text{ dBm}$	$f_{\text{CLKin0}} = 100 \text{ MHz}$		-84	dBc
			$f_{\text{CLKin0}} = 200 \text{ MHz}$		-82	
			$f_{\text{CLKin0}} = 500 \text{ MHz}$		-71	
			$f_{\text{CLKin0}} = 1000 \text{ MHz}$		-65	
<b>CRYSTAL INTERFACE (OSCin, OSCout)</b>						
$F_{\text{CLK}}$	External Clock Frequency Range <sup>(5)</sup>	OSCin driven single-ended, OSCout floating			250	MHz
$F_{\text{XTAL}}$	Crystal Frequency Range	Fundamental mode crystal $\text{ESR} \leq 200 \text{ } \Omega$ (10 to 30 MHz) $\text{ESR} \leq 125 \text{ } \Omega$ (30 to 40 MHz) <sup>(9)</sup>	10		40	MHz
$C_{\text{IN}}$	OSCin Input Capacitance			4		pF

(5) Specification is ensured by characterization and is not tested in production.

(6) See [Differential Voltage Measurement Terminology](#) for definition of  $V_{\text{ID}}$  and  $V_{\text{OD}}$  voltages.

(7) Parameter is specified by design, not tested in production.

(8) For clock input frequency  $\geq 100 \text{ MHz}$ , CLKinX can be driven with single-ended (LVCMOS) input swing up to  $3.3 \text{ Vpp}$ . For clock input frequency  $< 100 \text{ MHz}$ , the single-ended input swing should be limited to  $2 \text{ Vpp}$  max to prevent input saturation (refer to [Driving the Clock Inputs](#) for interfacing  $2.5 \text{ V}/3.3 \text{ V}$  LVCMOS clock input  $< 100 \text{ MHz}$  to CLKinX).

(9) The ESR requirements stated must be met to ensure that the oscillator circuitry has no startup issues. However, lower ESR values for the crystal may be necessary to stay below the maximum power dissipation (drive level) specification of the crystal. Refer to [Crystal Interface](#) for crystal drive level considerations.

## Electrical Characteristics (continued)

Unless otherwise specified:  $V_{CC} = 3.3\text{ V} \pm 5\%$ ,  $V_{CCO} = 3.3\text{ V} \pm 5\%$ ,  $2.5\text{ V} \pm 5\%$ ,  $-40\text{ }^\circ\text{C} \leq T_A \leq 85\text{ }^\circ\text{C}$ , CLKin driven differentially, input slew rate  $\geq 3\text{ V/ns}$ . Typical values represent most likely parametric norms at  $V_{CC} = 3.3\text{ V}$ ,  $V_{CCO} = 3.3\text{ V}$ ,  $T_A = 25\text{ }^\circ\text{C}$ , and at the Recommended Operation Conditions at the time of product characterization and are not ensured. <sup>(1)</sup> <sup>(2)</sup>

PARAMETER		TEST CONDITIONS		MIN	TYP	MAX	UNIT
<b>LVPECL OUTPUTS (CLKoutAn/CLKoutAn*, CLKoutBn/CLKoutBn*)</b>							
$f_{\text{CLKout\_FS}}$	Maximum Output Frequency Full $V_{\text{OD}}$ Swing <sup>(5)(10)</sup>	$V_{\text{OD}} \geq 600\text{ mV}$ , $R_L = 100\text{ }\Omega$ differential	$V_{\text{CCO}} = 3.3\text{ V} \pm 5\%$ , $R_T = 160\text{ }\Omega$ to GND	1.0	1.2		GHz
			$V_{\text{CCO}} = 2.5\text{ V} \pm 5\%$ , $R_T = 91\text{ }\Omega$ to GND	0.75	1.0		
$f_{\text{CLKout\_RS}}$	Maximum Output Frequency Reduced $V_{\text{OD}}$ Swing <sup>(5)(10)</sup>	$V_{\text{OD}} \geq 400\text{ mV}$ , $R_L = 100\text{ }\Omega$ differential	$V_{\text{CCO}} = 3.3\text{ V} \pm 5\%$ , $R_T = 160\text{ }\Omega$ to GND	1.5	3.1		GHz
			$V_{\text{CCO}} = 2.5\text{ V} \pm 5\%$ , $R_T = 91\text{ }\Omega$ to GND	1.5	2.3		
Jitter <sub>ADD</sub>	Additive RMS Jitter, Integration Bandwidth 10 kHz to 20 MHz <sup>(5)(11)(12)</sup>	$V_{\text{CCO}} = 2.5\text{ V} \pm 5\%$ : $R_T = 91\text{ }\Omega$ to GND, $V_{\text{CCO}} = 3.3\text{ V} \pm 5\%$ : $R_T = 160\text{ }\Omega$ to GND, $R_L = 100\text{ }\Omega$ differential	CLKin: 100 MHz, Slew rate $\geq 3\text{ V/ns}$		77	98	fs
			CLKin: 156.25 MHz, Slew rate $\geq 3\text{ V/ns}$		54	78	
Jitter <sub>ADD</sub>	Additive RMS Jitter Integration Bandwidth 1 MHz to 20 MHz <sup>(11)</sup>	$V_{\text{CCO}} = 3.3\text{ V}$ , $R_T = 160\text{ }\Omega$ to GND, $R_L = 100\text{ }\Omega$ differential	CLKin: 100 MHz, Slew rate $\geq 3\text{ V/ns}$		59		fs
			CLKin: 156.25 MHz, Slew rate $\geq 2.7\text{ V/ns}$		64		
			CLKin: 625 MHz, Slew rate $\geq 3\text{ V/ns}$		30		
Jitter <sub>ADD</sub>	Additive RMS Jitter with LVPECL clock source from LMK03806 <sup>(11)(13)</sup>	$V_{\text{CCO}} = 3.3\text{ V}$ , $R_T = 160\text{ }\Omega$ to GND, $R_L = 100\text{ }\Omega$ differential	CLKin: 156.25 MHz, $J_{\text{SOURCE}} = 190\text{ fs RMS}$ (10 kHz to 1 MHz)		20		fs
			CLKin: 156.25 MHz, $J_{\text{SOURCE}} = 195\text{ fs RMS}$ (12 kHz to 20 MHz)		51		
Noise Floor	Noise Floor $f_{\text{OFFSET}} \geq 10\text{ MHz}$ <sup>(14)(15)</sup>	$V_{\text{CCO}} = 3.3\text{ V}$ , $R_T = 160\text{ }\Omega$ to GND, $R_L = 100\text{ }\Omega$ differential	CLKin: 100 MHz, Slew rate $\geq 3\text{ V/ns}$		-162.5		dBc/Hz
			CLKin: 156.25 MHz, Slew rate $\geq 2.7\text{ V/ns}$		-158.1		
			CLKin: 625 MHz, Slew rate $\geq 3\text{ V/ns}$		-154.4		
DUTY	Duty Cycle <sup>(5)</sup>	50% input clock duty cycle		45%		55%	
$V_{\text{OH}}$	Output High Voltage	$T_A = 25\text{ }^\circ\text{C}$ , DC Measurement, $R_T = 50\text{ }\Omega$ to $V_{\text{CCO}} - 2\text{ V}$		$V_{\text{CCO}} - 1.2$	$V_{\text{CCO}} - 0.9$	$V_{\text{CCO}} - 0.7$	V
$V_{\text{OL}}$	Output Low Voltage			$V_{\text{CCO}} - 2.0$	$V_{\text{CCO}} - 1.75$	$V_{\text{CCO}} - 1.5$	V
$V_{\text{OD}}$	Output Voltage Swing <sup>(6)</sup>			600	830	1000	mV

(10) See [Typical Characteristics](#) for output operation over frequency.

(11) For the 100 MHz and 156.25 MHz clock input conditions, Additive RMS Jitter ( $J_{\text{ADD}}$ ) is calculated using Method #1:  $J_{\text{ADD}} = \text{SQRT}(J_{\text{OUT}}^2 - J_{\text{SOURCE}}^2)$ , where  $J_{\text{OUT}}$  is the total RMS jitter measured at the output driver and  $J_{\text{SOURCE}}$  is the RMS jitter of the clock source applied to CLKin. For the 625 MHz clock input condition, Additive RMS Jitter is approximated using Method #2:  $J_{\text{ADD}} = \text{SQRT}(2 \cdot 10^{\text{dBc}/10} / (2 \cdot \pi \cdot f_{\text{CLK}}))$ , where dBc is the phase noise power of the Output Noise Floor integrated from 1 to 20 MHz bandwidth. The phase noise power can be calculated as: dBc = Noise Floor +  $10 \cdot \log_{10}(20\text{ MHz} - 1\text{ MHz})$ . The additive RMS jitter was approximated for 625 MHz using Method #2 because the RMS jitter of the clock source was not sufficiently low enough to allow practical use of Method #1. Refer to the "Noise Floor vs. CLKin Slew Rate" and "RMS Jitter vs. CLKin Slew Rate" plots in [Typical Characteristics](#).

(12) 100 MHz and 156.25 MHz input source from Rohde & Schwarz SMA100A Low-Noise Signal Generator and Sine-to-Square-wave Conversion block.

(13) 156.25 MHz LVPECL clock source from LMK03806 with 20 MHz crystal reference (crystal part number: ECS-200-20-30BU-DU).  $J_{\text{SOURCE}} = 190\text{ fs RMS}$  (10 kHz to 1 MHz) and  $195\text{ fs RMS}$  (12 kHz to 20 MHz). Refer to the LMK03806 datasheet for more information.

(14) The noise floor of the output buffer is measured as the far-out phase noise of the buffer. Typically this offset is  $\geq 10\text{ MHz}$ , but for lower frequencies this measurement offset can be as low as 5 MHz due to measurement equipment limitations.

(15) Phase noise floor will degrade as the clock input slew rate is reduced. Compared to a single-ended clock, a differential clock input (LVPECL, LVDS) will be less susceptible to degradation in noise floor at lower slew rates due to its common mode noise rejection. However, it is recommended to use the highest possible input slew rate for differential clocks to achieve optimal noise floor performance at the device outputs.

**Electrical Characteristics (continued)**

Unless otherwise specified:  $V_{CC} = 3.3\text{ V} \pm 5\%$ ,  $V_{CCO} = 3.3\text{ V} \pm 5\%$ ,  $2.5\text{ V} \pm 5\%$ ,  $-40\text{ }^\circ\text{C} \leq T_A \leq 85\text{ }^\circ\text{C}$ , CLKin driven differentially, input slew rate  $\geq 3\text{ V/ns}$ . Typical values represent most likely parametric norms at  $V_{CC} = 3.3\text{ V}$ ,  $V_{CCO} = 3.3\text{ V}$ ,  $T_A = 25\text{ }^\circ\text{C}$ , and at the Recommended Operation Conditions at the time of product characterization and are not ensured. <sup>(1) (2)</sup>

PARAMETER		TEST CONDITIONS	MIN	TYP	MAX	UNIT
$t_R$	Output Rise Time 20% to 80% <sup>(7)</sup>	$R_T = 160\ \Omega$ to GND, Uniform transmission line up to 10 in. with 50- $\Omega$ characteristic impedance, $R_L = 100\ \Omega$ differential, $C_L \leq 5\text{ pF}$		175	300	ps
$t_F$	Output Fall Time 80% to 20% <sup>(7)</sup>			175	300	ps
<b>LVDS OUTPUTS (CLKoutAn/CLKoutAn*, CLKoutBn/CLKoutBn*)</b>						
$f_{\text{CLKout\_FS}}$	Maximum Output Frequency Full $V_{OD}$ Swing <sup>(5)(10)</sup>	$V_{OD} \geq 250\text{ mV}$ , $R_L = 100\ \Omega$ differential	1.0	1.6		GHz
$f_{\text{CLKout\_RS}}$	Maximum Output Frequency Reduced $V_{OD}$ Swing <sup>(5)(10)</sup>	$V_{OD} \geq 200\text{ mV}$ , $R_L = 100\ \Omega$ differential	1.5	2.1		GHz
$\text{Jitter}_{\text{ADD}}$	Additive RMS Jitter, Integration Bandwidth 10 kHz to 20 MHz <sup>(5)(11)(12)</sup>	$R_L = 100\ \Omega$ differential	CLKin: 100 MHz, Slew rate $\geq 3\text{ V/ns}$	94	115	fs
			CLKin: 156.25 MHz, Slew rate $\geq 3\text{ V/ns}$	70	90	
$\text{Jitter}_{\text{ADD}}$	Additive RMS Jitter Integration Bandwidth 1 MHz to 20 MHz <sup>(11)</sup>	$V_{CCO} = 3.3\text{ V}$ , $R_L = 100\ \Omega$ differential	CLKin: 100 MHz, Slew rate $\geq 3\text{ V/ns}$	89		fs
			CLKin: 156.25 MHz, Slew rate $\geq 2.7\text{ V/ns}$	77		
			CLKin: 625 MHz, Slew rate $\geq 3\text{ V/ns}$	37		
Noise Floor	Noise Floor $f_{\text{OFFSET}} \geq 10\text{ MHz}$ <sup>(14)(15)</sup>	$V_{CCO} = 3.3\text{ V}$ , $R_L = 100\ \Omega$ differential	CLKin: 100 MHz, Slew rate $\geq 3\text{ V/ns}$	-159.5		dBc/Hz
			CLKin: 156.25 MHz, Slew rate $\geq 2.7\text{ V/ns}$	-157.0		
			CLKin: 625 MHz, Slew rate $\geq 3\text{ V/ns}$	-152.7		
DUTY	Duty Cycle <sup>(5)</sup>	50% input clock duty cycle	45%		55%	
$V_{OD}$	Output Voltage Swing <sup>(6)</sup>	$T_A = 25\text{ }^\circ\text{C}$ , DC Measurement, $R_L = 100\ \Omega$ differential	250	400	450	mV
$\Delta V_{OD}$	Change in Magnitude of $V_{OD}$ for Complementary Output States		-50		50	mV
$V_{OS}$	Output Offset Voltage		1.125	1.25	1.375	V
$\Delta V_{OS}$	Change in Magnitude of $V_{OS}$ for Complementary Output States		-35		35	mV
$I_{SA}$ $I_{SB}$	Output Short Circuit Current Single Ended		$T_A = 25\text{ }^\circ\text{C}$ , Single ended outputs shorted to GND	-24		24
$I_{SAB}$	Output Short Circuit Current Differential	Complementary outputs tied together	-12		12	mA
$t_R$	Output Rise Time 20% to 80% <sup>(7)</sup>	Uniform transmission line up to 10 inches with 50- $\Omega$ characteristic impedance, $R_L = 100\ \Omega$ differential, $C_L \leq 5\text{ pF}$		175	300	ps
$t_F$	Output Fall Time 80% to 20% <sup>(7)</sup>			175	300	ps

## Electrical Characteristics (continued)

Unless otherwise specified:  $V_{CC} = 3.3\text{ V} \pm 5\%$ ,  $V_{CC0} = 3.3\text{ V} \pm 5\%$ ,  $2.5\text{ V} \pm 5\%$ ,  $-40\text{ }^\circ\text{C} \leq T_A \leq 85\text{ }^\circ\text{C}$ , CLKin driven differentially, input slew rate  $\geq 3\text{ V/ns}$ . Typical values represent most likely parametric norms at  $V_{CC} = 3.3\text{ V}$ ,  $V_{CC0} = 3.3\text{ V}$ ,  $T_A = 25\text{ }^\circ\text{C}$ , and at the Recommended Operation Conditions at the time of product characterization and are not ensured. <sup>(1) (2)</sup>

PARAMETER		TEST CONDITIONS		MIN	TYP	MAX	UNIT
<b>HCSL OUTPUTS (CLKoutAn/CLKoutAn*, CLKoutBn/CLKoutBn*)</b>							
$f_{\text{CLKout}}$	Output Frequency Range <sup>(5)</sup>	$R_L = 50\ \Omega$ to GND, $C_L \leq 5\text{ pF}$		DC		400	MHz
Jitter <sub>ADD_PClE</sub>	Additive RMS Phase Jitter for PCIe 3.0 <sup>(5)</sup>	PCIe Gen 3, PLL BW = 2–5 MHz, CDR = 10 MHz	CLKin: 100 MHz, Slew rate $\geq 0.6\text{ V/ns}$		0.03	0.15	ps
Jitter <sub>ADD</sub>	Additive RMS Jitter Integration Bandwidth 1 MHz to 20 MHz <sup>(11)</sup>	$V_{CC0} = 3.3\text{ V}$ , $R_T = 50\ \Omega$ to GND	CLKin: 100 MHz, Slew rate $\geq 3\text{ V/ns}$		77		fs
			CLKin: 156.25 MHz, Slew rate $\geq 2.7\text{ V/ns}$		86		
Noise Floor	Noise Floor $f_{\text{OFFSET}} \geq 10\text{ MHz}$ <sup>(14)(15)</sup>	$V_{CC0} = 3.3\text{ V}$ , $R_T = 50\ \Omega$ to GND	CLKin: 100 MHz, Slew rate $\geq 3\text{ V/ns}$		-161.3		dBc/Hz
			CLKin: 156.25 MHz, Slew rate $\geq 2.7\text{ V/ns}$		-156.3		
DUTY	Duty Cycle <sup>(5)</sup>	50% input clock duty cycle		45%		55%	
$V_{\text{OH}}$	Output High Voltage	$T_A = 25\text{ }^\circ\text{C}$ , DC Measurement, $R_T = 50\ \Omega$ to GND		520	810	920	mV
$V_{\text{OL}}$	Output Low Voltage			-150	0.5	150	mV
$V_{\text{CROSS}}$	Absolute Crossing Voltage <sup>(5)(16)</sup>	$R_L = 50\ \Omega$ to GND, $C_L \leq 5\text{ pF}$		160	350	460	mV
$\Delta V_{\text{CROSS}}$	Total Variation of $V_{\text{CROSS}}$ <sup>(5)(16)</sup>					140	mV
$t_R$	Output Rise Time 20% to 80% <sup>(7)(16)</sup>	250 MHz, Uniform transmission line up to 10 inches with 50- $\Omega$ characteristic impedance, $R_L = 50\ \Omega$ to GND, $C_L \leq 5\text{ pF}$			300	500	ps
$t_F$	Output Fall Time 80% to 20% <sup>(7)(16)</sup>				300	500	ps

(16) AC timing parameters for HCSL or CMOS are dependent on output capacitive loading.

## Electrical Characteristics (continued)

Unless otherwise specified:  $V_{CC} = 3.3\text{ V} \pm 5\%$ ,  $V_{CCO} = 3.3\text{ V} \pm 5\%$ ,  $2.5\text{ V} \pm 5\%$ ,  $-40\text{ }^\circ\text{C} \leq T_A \leq 85\text{ }^\circ\text{C}$ , CLK<sub>in</sub> driven differentially, input slew rate  $\geq 3\text{ V/ns}$ . Typical values represent most likely parametric norms at  $V_{CC} = 3.3\text{ V}$ ,  $V_{CCO} = 3.3\text{ V}$ ,  $T_A = 25\text{ }^\circ\text{C}$ , and at the Recommended Operation Conditions at the time of product characterization and are not ensured. <sup>(1)</sup> <sup>(2)</sup>

PARAMETER		TEST CONDITIONS		MIN	TYP	MAX	UNIT
<b>LVC MOS OUTPUT (REF<sub>out</sub>)</b>							
$f_{CLKout}$	Output Frequency Range <sup>(5)</sup>	$C_L \leq 5\text{ pF}$		DC		250	MHz
Jitter <sub>ADD</sub>	Additive RMS Jitter Integration Bandwidth 1 MHz to 20 MHz <sup>(11)</sup>	$V_{CCO} = 3.3\text{ V}$ , $C_L \leq 5\text{ pF}$	100 MHz, Input Slew rate $\geq 3\text{ V/ns}$		95		fs
Noise Floor	Noise Floor $f_{OFFSET} \geq 10\text{ MHz}$ <sup>(14)(15)</sup>	$V_{CCO} = 3.3\text{ V}$ , $C_L \leq 5\text{ pF}$	100 MHz, Input Slew rate $\geq 3\text{ V/ns}$		-159.3		dBc/Hz
DUTY	Duty Cycle <sup>(5)</sup>	50% input clock duty cycle		45%		55%	
$V_{OH}$	Output High Voltage	1 mA load		$V_{CCO} - 0.1$			V
$V_{OL}$	Output Low Voltage					0.1	V
$I_{OH}$	Output High Current (Source)	$V_o = V_{CCO} / 2$		$V_{CCO} = 3.3\text{ V}$	28		mA
				$V_{CCO} = 2.5\text{ V}$	20		
$I_{OL}$	Output Low Current (Sink)			$V_{CCO} = 3.3\text{ V}$	28		mA
				$V_{CCO} = 2.5\text{ V}$	20		
$t_R$	Output Rise Time 20% to 80% <sup>(7)(16)</sup>	250 MHz, Uniform transmission line up to 10 inches with 50- $\Omega$ characteristic impedance, $R_L = 50\ \Omega$ to GND, $C_L \leq 5\text{ pF}$			225	400	ps
$t_F$	Output Fall Time 80% to 20% <sup>(7)(16)</sup>				225	400	ps
$t_{EN}$	Output Enable Time <sup>(17)</sup>	$C_L \leq 5\text{ pF}$				3	cycles
$t_{DIS}$	Output Disable Time <sup>(17)</sup>					3	cycles

(17) Output Enable Time is the number of input clock cycles it takes for the output to be enabled after REF<sub>out</sub>\_EN is pulled high. Similarly, Output Disable Time is the number of input clock cycles it takes for the output to be disabled after REF<sub>out</sub>\_EN is pulled low. The REF<sub>out</sub>\_EN signal should have an edge transition much faster than that of the input clock period for accurate measurement.

## Electrical Characteristics (continued)

Unless otherwise specified:  $V_{CC} = 3.3\text{ V} \pm 5\%$ ,  $V_{CCO} = 3.3\text{ V} \pm 5\%$ ,  $2.5\text{ V} \pm 5\%$ ,  $-40\text{ }^{\circ}\text{C} \leq T_A \leq 85\text{ }^{\circ}\text{C}$ , CLKin driven differentially, input slew rate  $\geq 3\text{ V/ns}$ . Typical values represent most likely parametric norms at  $V_{CC} = 3.3\text{ V}$ ,  $V_{CCO} = 3.3\text{ V}$ ,  $T_A = 25\text{ }^{\circ}\text{C}$ , and at the Recommended Operation Conditions at the time of product characterization and are not ensured. <sup>(1)</sup> <sup>(2)</sup>

PARAMETER	TEST CONDITIONS	MIN	TYP	MAX	UNIT		
<b>PROPAGATION DELAY and OUTPUT SKEW</b>							
$t_{PD\_PECL}$	Propagation Delay CLKin-to-LVPECL <sup>(7)</sup>	$R_T = 160\ \Omega$ to GND, $R_L = 100\ \Omega$ differential, $C_L \leq 5\text{ pF}$		180	360	540	ps
$t_{PD\_LVDS}$	Propagation Delay CLKin-to-LVDS <sup>(7)</sup>	$R_L = 100\ \Omega$ differential, $C_L \leq 5\text{ pF}$		200	400	600	ps
$t_{PD\_HCSL}$	Propagation Delay CLKin-to-HCSL <sup>(7)(16)</sup>	$R_T = 50\ \Omega$ to GND, $C_L \leq 5\text{ pF}$		295	590	885	ps
$t_{PD\_CMOS}$	Propagation Delay CLKin-to-LVCMOS <sup>(7)(16)</sup>	$C_L \leq 5\text{ pF}$	$V_{CCO} = 3.3\text{ V}$	900	1475	2300	ps
			$V_{CCO} = 2.5\text{ V}$	1000	1550	2700	
$t_{SK(O)}$	Output Skew LVPECL/LVDS/HCSL <sup>(5)(16)(18)</sup>	Skew specified between any two CLKouts with the same buffer type. Load conditions per output type are the same as propagation delay specifications.			30	50	ps
$t_{SK(PP)}$	Part-to-Part Output Skew LVPECL/LVDS/HCSL <sup>(7)(16)(18)</sup>				80	120	ps

(18) Output skew is the propagation delay difference between any two outputs with identical output buffer type and equal loading while operating at the same supply voltage and temperature conditions.

## 7.6 Typical Characteristics

Unless otherwise specified:  $V_{CC} = 3.3\text{ V}$ ,  $V_{CCO} = 3.3\text{ V}$ ,  $T_A = 25\text{ }^\circ\text{C}$ , CLKin driven differentially, input slew rate  $\geq 3\text{ V/ns}$ . Consult Table 1 at the end of *Typical Characteristics* for graph notes.

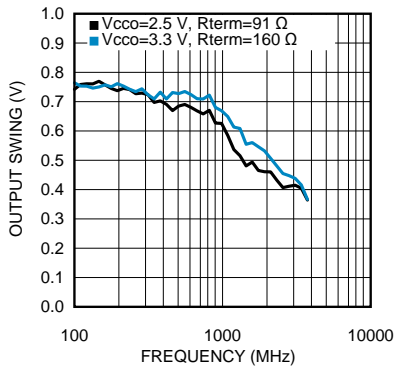

Figure 1. LVPECL Output Swing ( $V_{OD}$ ) vs. Frequency

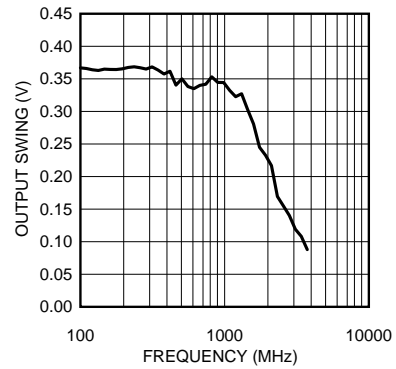

Figure 2. LVDS Output Swing ( $V_{OD}$ ) vs. Frequency

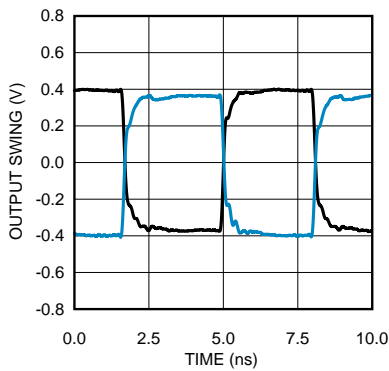

Figure 3. LVPECL Output Swing @ 156.25 MHz

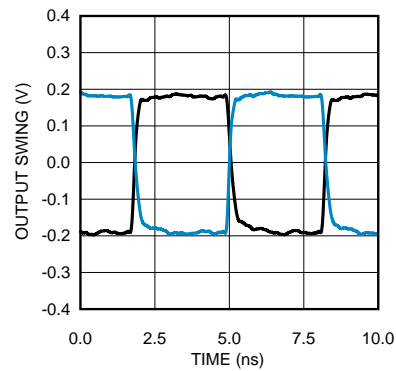

Figure 4. LVDS Output Swing @ 156.25 MHz

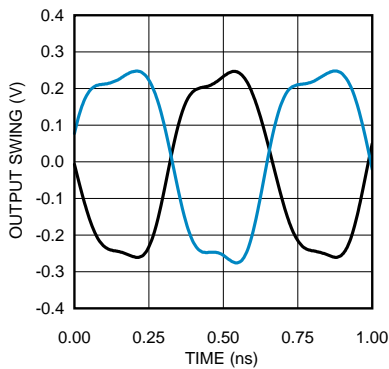

Figure 5. LVPECL Output Swing @ 1.5 GHz

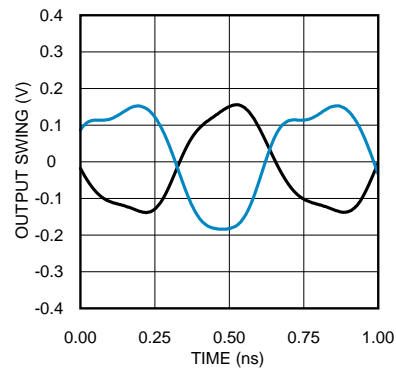

Figure 6. LVDS Output Swing @ 1.5 GHz

Typical Characteristics (continued)

Unless otherwise specified:  $V_{CC} = 3.3\text{ V}$ ,  $V_{CC0} = 3.3\text{ V}$ ,  $T_A = 25\text{ }^\circ\text{C}$ , CLKin driven differentially, input slew rate  $\geq 3\text{ V/ns}$ . Consult Table 1 at the end of Typical Characteristics for graph notes.

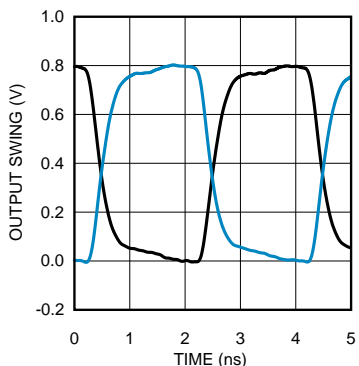

Figure 7. HCSL Output Swing @ 250 MHz

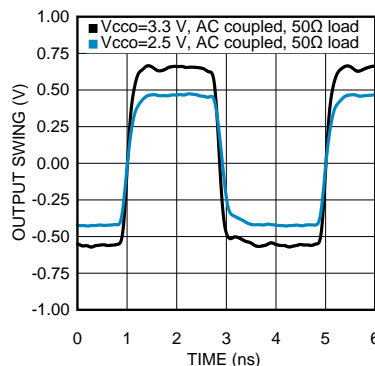

Figure 8. LVCMOS Output Swing @ 250 MHz

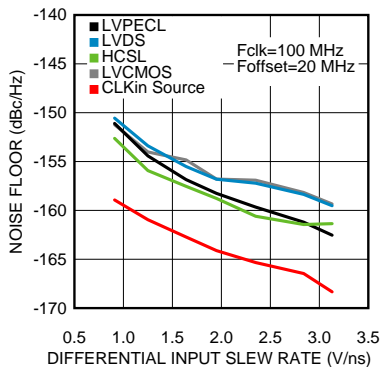

Figure 9. Noise Floor vs. CLKin Slew Rate @ 100 MHz

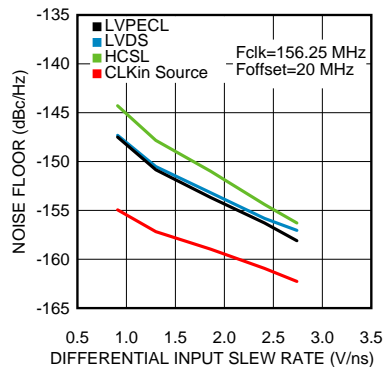

Figure 10. Noise Floor vs. CLKin Slew Rate @ 156.25 MHz

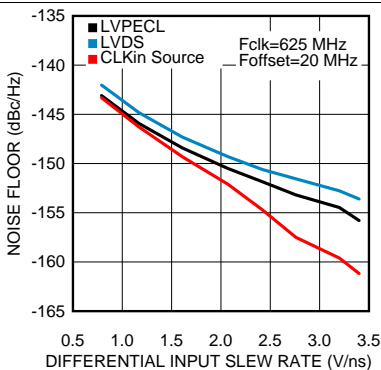
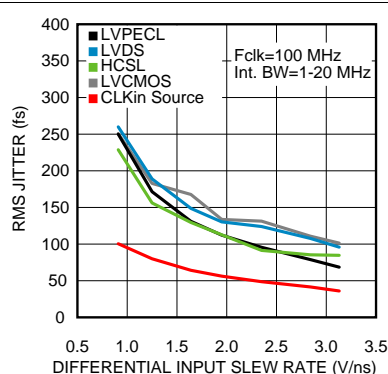

Figure 11. Noise Floor vs. CLKin Slew Rate @ 625 MHz



See Note 1 in Graph Notes table

Figure 12. RMS Jitter vs. CLKin Slew Rate @ 100 MHz

### Typical Characteristics (continued)

Unless otherwise specified:  $V_{CC} = 3.3\text{ V}$ ,  $V_{CC0} = 3.3\text{ V}$ ,  $T_A = 25\text{ }^\circ\text{C}$ , CLKin driven differentially, input slew rate  $\geq 3\text{ V/ns}$ . Consult [Table 1](#) at the end of *Typical Characteristics* for graph notes.

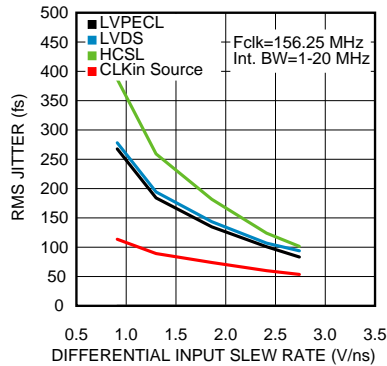

See Note 1 Graph Notes table.

Figure 13. RMS Jitter vs. CLKin Slew Rate @ 156.25 MHz

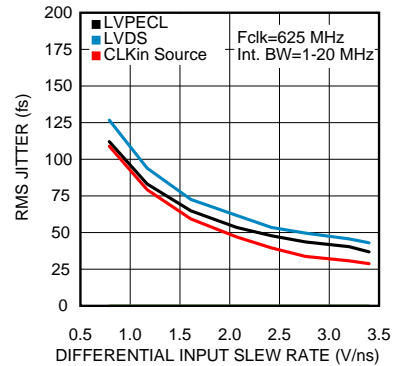

Figure 14. RMS Jitter vs. CLKin Slew Rate @ 625 MHz

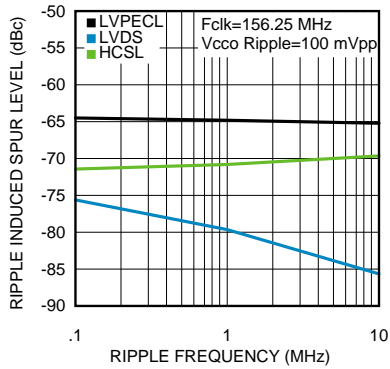

Figure 15. PSRR vs. Ripple Frequency @ 156.25 MHz

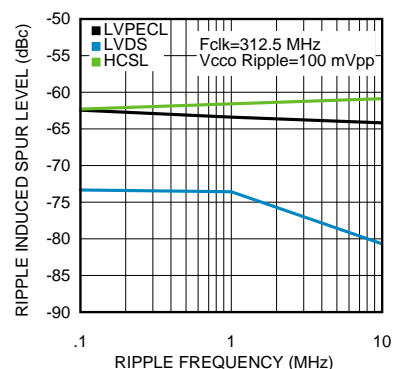

Figure 16. PSRR vs. Ripple Frequency @ 312.5 MHz

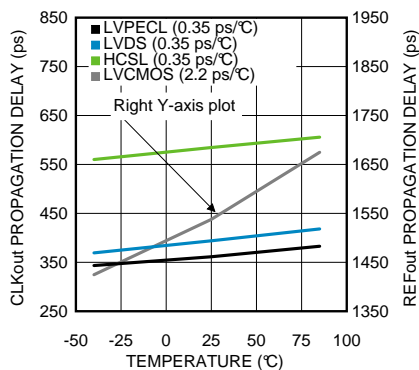
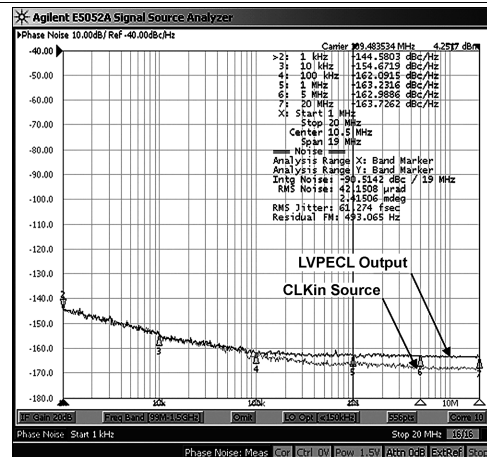

Figure 17. Propagation Delay vs. Temperature



See Note 1 in Graph Notes table

Figure 18. LVPECL Phase Noise @ 100 MHz

Typical Characteristics (continued)

Unless otherwise specified: V<sub>CC</sub> = 3.3 V, V<sub>CC0</sub> = 3.3 V, T<sub>A</sub> = 25 °C, CLKin driven differentially, input slew rate ≥ 3 V/ns. Consult Table 1 at the end of Typical Characteristics for graph notes.

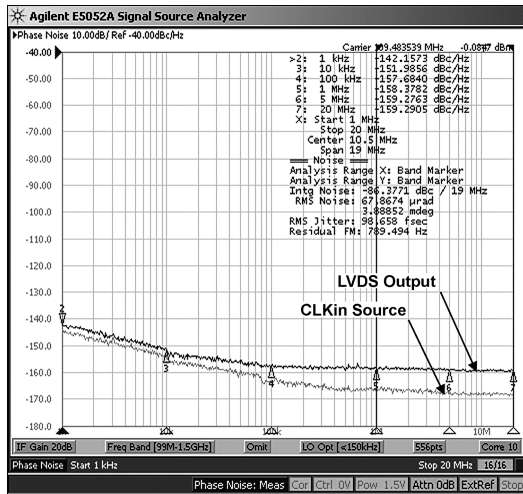

See Note 1 in Graph Notes table

Figure 19. LVDS Phase Noise @ 100 MHz

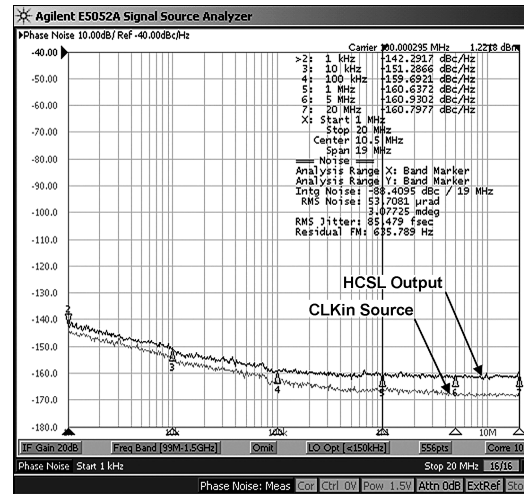

See Note 1 in Graph Notes table

Figure 20. HCSL Phase Noise @ 100 MHz

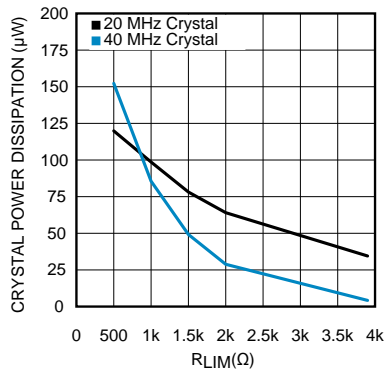

See Notes 2 and 3 in Graph Notes table

Figure 21. Crystal Power Dissipation vs. R<sub>LIM</sub>

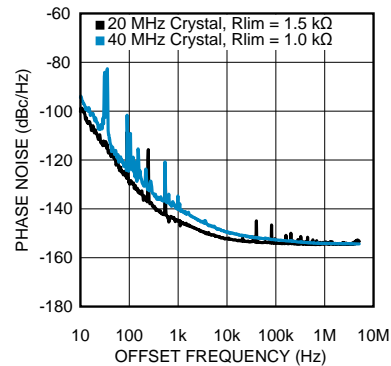

See Notes 2 and 3 in Graph Notes table

Figure 22. LVDS Phase Noise in Crystal Mode

Table 1. Graph Notes

NOTE	
(1)	The typical RMS jitter values in the plots show the total output RMS jitter (J <sub>OUT</sub> ) for each output buffer type and the source clock RMS jitter (J <sub>SOURCE</sub> ). From these values, the Additive RMS Jitter can be calculated as: J <sub>ADD</sub> = SQRT(J <sub>OUT</sub> <sup>2</sup> - J <sub>SOURCE</sub> <sup>2</sup> ).
(2)	20 MHz crystal characteristics: Abracon ABL series, AT cut, C <sub>L</sub> = 18 pF, C <sub>0</sub> = 4.4 pF measured (7 pF max), ESR = 8.5 Ω measured (40 Ω max), and Drive Level = 1 mW max (100 µW typical).
(3)	40 MHz crystal characteristics: Abracon ABLS2 series, AT cut, C <sub>L</sub> = 18 pF, C <sub>0</sub> = 5 pF measured (7 pF max), ESR = 5 Ω measured (40 Ω max), and Drive Level = 1 mW max (100 µW typical).

## 8 Parameter Measurement Information

### 8.1 Differential Voltage Measurement Terminology

The differential voltage of a differential signal can be described by two different definitions causing confusion when reading datasheets or communicating with other engineers. This section will address the measurement and description of a differential signal so that the reader will be able to understand and discern between the two different definitions when used.

The first definition used to describe a differential signal is the absolute value of the voltage potential between the inverting and non-inverting signal. The symbol for this first measurement is typically  $V_{ID}$  or  $V_{OD}$  depending on if an input or output voltage is being described.

The second definition used to describe a differential signal is to measure the potential of the non-inverting signal with respect to the inverting signal. The symbol for this second measurement is  $V_{SS}$  and is a calculated parameter. Nowhere in the IC does this signal exist with respect to ground, it only exists in reference to its differential pair.  $V_{SS}$  can be measured directly by oscilloscopes with floating references, otherwise this value can be calculated as twice the value of  $V_{OD}$  as described in the first description.

Figure 23 illustrates the two different definitions side-by-side for inputs and Figure 24 illustrates the two different definitions side-by-side for outputs. The  $V_{ID}$  (or  $V_{OD}$ ) definition show the DC levels,  $V_{IH}$  and  $V_{OL}$  (or  $V_{OH}$  and  $V_{OL}$ ), that the non-inverting and inverting signals toggle between with respect to ground.  $V_{SS}$  input and output definitions show that if the inverting signal is considered the voltage potential reference, the non-inverting signal voltage potential is now increasing and decreasing above and below the non-inverting reference. Thus the peak-to-peak voltage of the differential signal can be measured.

$V_{ID}$  and  $V_{OD}$  are often defined as volts (V) and  $V_{SS}$  is often defined as volts peak-to-peak ( $V_{PP}$ ).

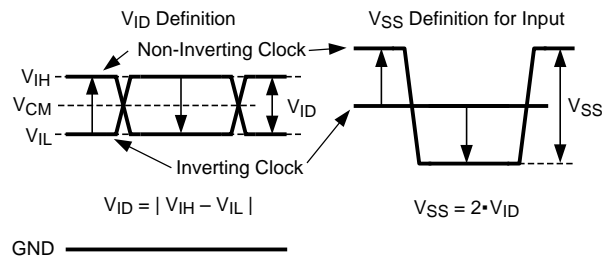

Figure 23. Two Different Definitions for Differential Input Signals

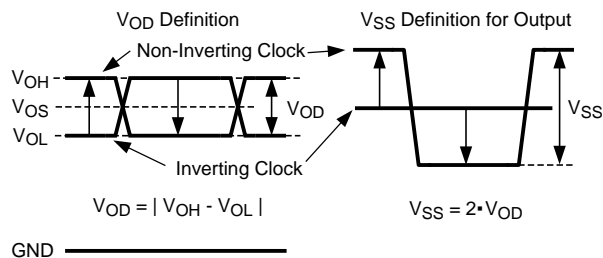

Figure 24. Two Different Definitions for Differential Output Signals

Refer to Application Note AN-912 (literature number [SNLA036](#)), *Common Data Transmission Parameters and their Definitions*, for more information.

## 9 Detailed Description

### 9.1 Overview

The LMK00308 is an 8-output differential clock fanout buffer with low additive jitter that can operate up to 3.1 GHz. It features a 3:1 input multiplexer with an optional crystal oscillator input, two banks of 4 differential outputs with multi-mode buffers (LVPECL, LVDS, HCSL, or Hi-Z), one LVCMOS output, and 3 independent output buffer supplies. The input selection and output buffer modes are controlled via pin strapping. The device is offered in a 40-pin WQFN package and leverages much of the high-speed, low-noise circuit design employed in the LMK04800 family of clock conditioners.

### 9.2 Functional Block Diagram

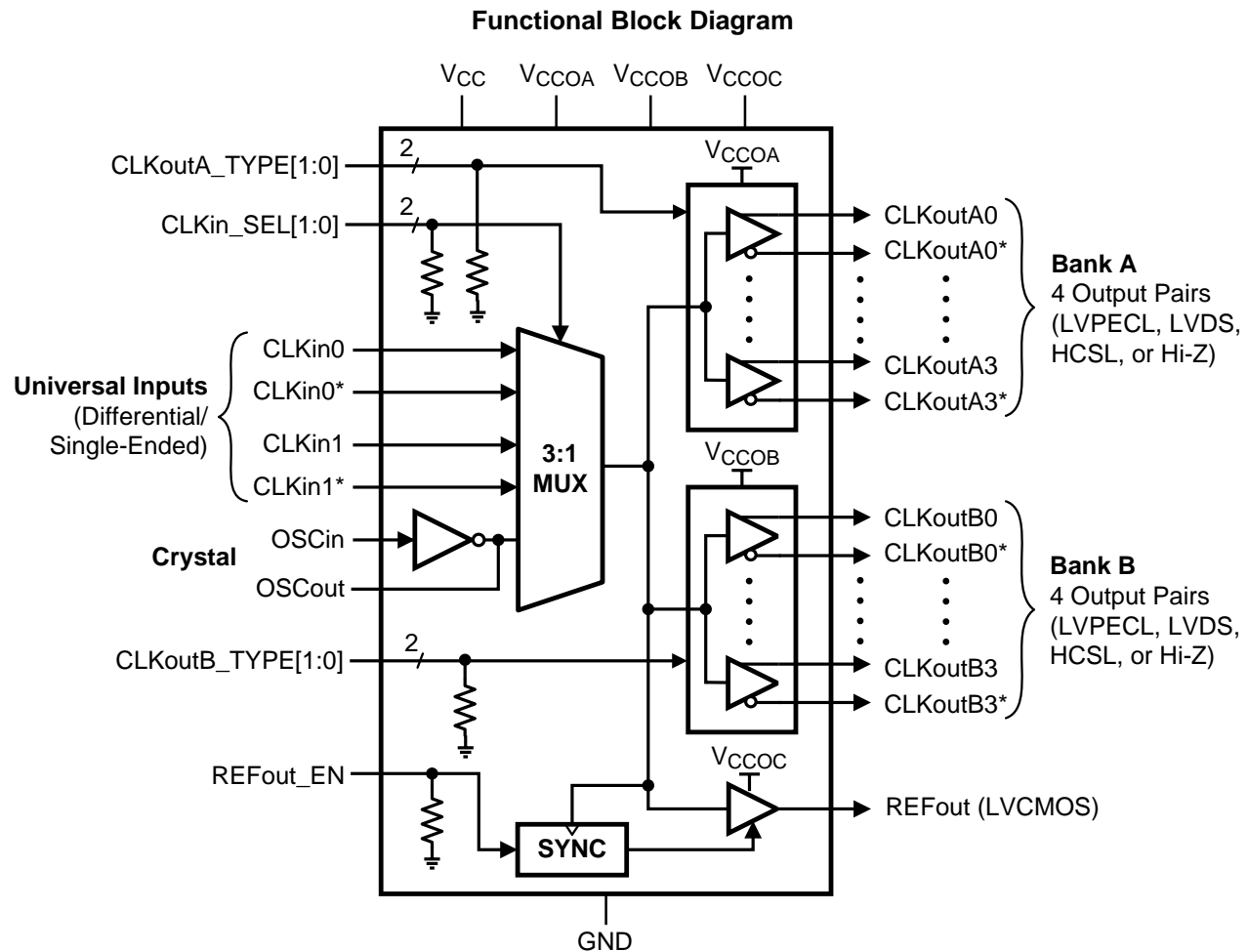

## 9.3 Feature Description

### 9.3.1 $V_{CC}$ and $V_{CCO}$ Power Supplies

The LMK00308 has a 3.3 V core power supply ( $V_{CC}$ ) and 3 independent 3.3 V/2.5 V output power supplies ( $V_{CCOA}$ ,  $V_{CCOB}$ ,  $V_{CCOC}$ ). Output supply operation at 2.5 V enables lower power consumption and output-level compatibility with 2.5 V receiver devices. The output levels for LVPECL ( $V_{OH}$ ,  $V_{OL}$ ) and LVCMOS ( $V_{OH}$ ) are referenced to the respective  $V_{CCO}$  supply, while the output levels for LVDS and HCSL are relatively constant over the specified  $V_{CCO}$  range. Refer to [Power Supply Recommendations](#) for additional supply related considerations, such as power dissipation, power supply bypassing, and power supply ripple rejection (PSRR).

#### NOTE

Care should be taken to ensure the  $V_{CCO}$  voltages do not exceed the  $V_{CC}$  voltage to prevent turning-on the internal ESD protection circuitry.

### 9.3.2 Clock Inputs

The input clock can be selected from CLKin0/CLKin0\*, CLKin1/CLKin1\*, or OSCin. Clock input selection is controlled using the CLKin\_SEL[1:0] inputs as shown in [Table 2](#). Refer to [Driving the Clock Inputs](#) for clock input requirements. When CLKin0 or CLKin1 is selected, the crystal circuit is powered down. When OSCin is selected, the crystal oscillator circuit will start-up and its clock will be distributed to all outputs. Refer to [Crystal Interface](#) for more information. Alternatively, OSCin may be driven by a single-ended clock (up to 250 MHz) instead of a crystal.

**Table 2. Input Selection**

CLKin_SEL1	CLKin_SEL0	SELECTED INPUT
0	0	CLKin0, CLKin0*
0	1	CLKin1, CLKin1*
1	X	OSCin

[Table 3](#) shows the output logic state vs. input state when either CLKin0/CLKin0\* or CLKin1/CLKin1\* is selected. When OSCin is selected, the output state will be an inverted copy of the OSCin input state.

**Table 3. CLKin Input vs. Output States**

STATE of SELECTED CLKin	STATE of ENABLED OUTPUTS
CLKinX and CLKinX* inputs floating	Logic low
CLKinX and CLKinX* inputs shorted together	Logic low
CLKin logic low	Logic low
CLKin logic high	Logic high

### 9.3.3 Clock Outputs

The differential output buffer type for Bank A and Bank B outputs can be separately configured using the CLKoutA\_TYPE[1:0] and CLKoutB\_TYPE[1:0] inputs, respectively, as shown in [Table 4](#). For applications where all differential outputs are not needed, any unused output pin should be left floating with a minimum copper length (see note below) to minimize capacitance and potential coupling and reduce power consumption. If an entire output bank will not be used, it is recommended to disable/Hi-Z the bank to reduce power. Refer to [Termination and Use of Clock Drivers](#) for more information on output interface and termination techniques.

#### NOTE

For best soldering practices, the minimum trace length for any unused output pin should extend to include the pin solder mask. This way during reflow, the solder has the same copper area as connected pins. This allows for good, uniform fillet solder joints helping to keep the IC level during reflow.

**Table 4. Differential Output Buffer Type Selection**

CLKoutX_TYPE1	CLKoutX_TYPE0	CLKoutX BUFFER TYPE (BANK A or B)
0	0	LVPECL
0	1	LVDS
1	0	HCSL
1	1	Disabled (Hi-Z)

#### 9.3.3.1 Reference Output

The reference output (REFout) provides a LVCMOS copy of the selected input clock. The LVCMOS output high level is referenced to the Vcco voltage. REFout can be enabled or disabled using the enable input pin, REFout\_EN, as shown in [Table 5](#).

**Table 5. Reference Output Enable**

REFout_EN	REFout STATE
0	Disabled (Hi-Z)
1	Enabled

The REFout\_EN input is internally synchronized with the selected input clock by the SYNC block. This synchronizing function prevents glitches and runt pulses from occurring on the REFout clock when enabled or disabled. REFout will be enabled within 3 cycles ( $t_{EN}$ ) of the input clock after REFout\_EN is toggled high. REFout will be disabled within 3 cycles ( $t_{DIS}$ ) of the input clock after REFout\_EN is toggled low.

When REFout is disabled, the use of a resistive loading can be used to set the output to a predetermined level. For example, if REFout is configured with a 1 k $\Omega$  load to ground, then the output will be pulled to low when disabled.

## 10 Application and Implementation

### NOTE

Information in the following applications sections is not part of the TI component specification, and TI does not warrant its accuracy or completeness. TI's customers are responsible for determining suitability of components for their purposes. Customers should validate and test their design implementation to confirm system functionality.

### 10.1 Driving the Clock Inputs

The LMK00308 has two universal inputs (CLKin0/CLKin0\* and CLKin1/CLKin1\*) that can accept AC- or DC-coupled 3.3V/2.5V LVPECL, LVDS, CML, SSTL, and other differential and single-ended signals that meet the input requirements specified in the [Electrical Characteristics](#). The device can accept a wide range of signals due to its wide input common mode voltage range ( $V_{CM}$ ) and input voltage swing ( $V_{ID}$ ) / dynamic range. For 50% duty cycle and DC-balanced signals, AC coupling may also be employed to shift the input signal to within the  $V_{CM}$  range. Refer to [Termination and Use of Clock Drivers](#) for signal interfacing and termination techniques.

To achieve the best possible phase noise and jitter performance, it is mandatory for the input to have high slew rate of 3 V/ns (differential) or higher. Driving the input with a lower slew rate will degrade the noise floor and jitter. For this reason, a differential signal input is recommended over single-ended because it typically provides higher slew rate and common-mode-rejection. Refer to the “Noise Floor vs. CLKin Slew Rate” and “RMS Jitter vs. CLKin Slew Rate” plots in [Typical Characteristics](#).

While it is recommended to drive the CLKin/CLKin\* pair with a differential signal input, it is possible to drive it with a single-ended clock provided it conforms to the Single-Ended Input specifications for CLKin pins listed in the [Electrical Characteristics](#). For large single-ended input signals, such as 3.3V or 2.5V LVCMOS, a 50  $\Omega$  load resistor should be placed near the input for signal attenuation to prevent input overdrive as well as for line termination to minimize reflections. Again, the single-ended input slew rate should be as high as possible to minimize performance degradation. The CLKin input has an internal bias voltage of about 1.4 V, so the input can be AC coupled as shown in [Figure 25](#). The output impedance of the LVCMOS driver plus  $R_S$  should be close to 50  $\Omega$  to match the characteristic impedance of the transmission line and load termination.

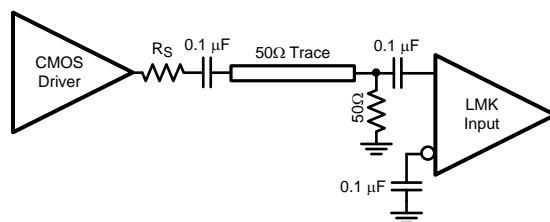
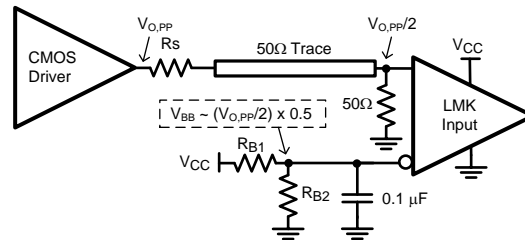

**Figure 25. Single-Ended LVCMOS Input, AC Coupling**

A single-ended clock may also be DC coupled to CLKinX as shown in [Figure 26](#). A 50- $\Omega$  load resistor should be placed near the CLKinX input for signal attenuation and line termination. Because half of the single-ended swing of the driver ( $V_{O,PP} / 2$ ) drives CLKinX, CLKinX\* should be externally biased to the midpoint voltage of the attenuated input swing ( $(V_{O,PP} / 2) \times 0.5$ ). The external bias voltage should be within the specified input common mode voltage ( $V_{CM}$ ) range. This can be achieved using external biasing resistors in the k $\Omega$  range ( $R_{B1}$  and  $R_{B2}$ ) or another low-noise voltage reference. This will ensure the input swing crosses the threshold voltage at a point where the input slew rate is the highest.

If the LVCMOS driver cannot achieve sufficient swing with a DC-terminated 50 $\Omega$  load at the CLKinX input as shown in [Figure 26](#), then consider connecting the 50 $\Omega$  load termination to ground through a capacitor ( $C_{AC}$ ). This AC termination blocks the DC load current on the driver, so the voltage swing at the input is determined by the voltage divider formed by the source ( $R_o+R_S$ ) and 50 $\Omega$  load resistors. The value for  $C_{AC}$  depends on the trace delay,  $T_d$ , of the 50 $\Omega$  transmission line, where  $C_{AC} \geq 3 \cdot T_d / 50\Omega$ .

## Driving the Clock Inputs (continued)



**Figure 26. Single-Ended LVCMOS Input, DC Coupling with Common Mode Biasing**

If the crystal oscillator circuit is not used, it is possible to drive the OSCin input with a single-ended external clock as shown in [Figure 27](#). The input clock should be AC coupled to the OSCin pin, which has an internally-generated input bias voltage, and the OSCout pin should be left floating. While OSCin provides an alternative input to multiplex an external clock, it is recommended to use either differential input (CLKinX) since it offers higher operating frequency, better common mode and power supply noise rejection, and greater performance over supply voltage and temperature variations.

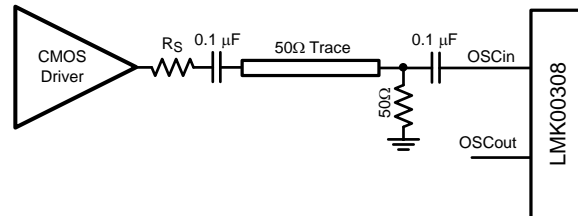

**Figure 27. Driving OSCin with a Single-Ended Input**

## 10.2 Crystal Interface

The LMK00308 has an integrated crystal oscillator circuit that supports a fundamental mode, AT-cut crystal. The crystal interface is shown in [Figure 28](#).

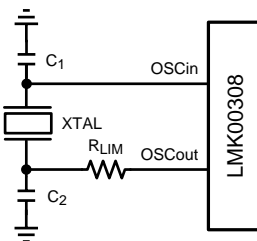

**Figure 28. Crystal Interface**

The load capacitance ( $C_L$ ) is specific to the crystal, but usually on the order of 18 - 20 pF. While  $C_L$  is specified for the crystal, the OSCin input capacitance ( $C_{IN} = 4$  pF typical) of the device and PCB stray capacitance ( $C_{STRAY} \sim 1\text{--}3$  pF) can affect the discrete load capacitor values,  $C_1$  and  $C_2$ .

For the parallel resonant circuit, the discrete capacitor values can be calculated as follows:

$$C_L = (C_1 * C_2) / (C_1 + C_2) + C_{IN} + C_{STRAY} \quad (1)$$

Typically,  $C_1 = C_2$  for optimum symmetry, so [Equation 1](#) can be rewritten in terms of  $C_1$  only:

$$C_L = C_1^2 / (2 * C_1) + C_{IN} + C_{STRAY} \quad (2)$$

Finally, solve for  $C_1$ :

$$C_1 = (C_L - C_{IN} - C_{STRAY}) * 2 \quad (3)$$

## Crystal Interface (continued)

[Electrical Characteristics](#) provides crystal interface specifications with conditions that ensure start-up of the crystal, but it does not specify crystal power dissipation. The designer will need to ensure the crystal power dissipation does not exceed the maximum drive level specified by the crystal manufacturer. Overdriving the crystal can cause premature aging, frequency shift, and eventual failure. Drive level should be held at a sufficient level necessary to start-up and maintain steady-state operation.

The power dissipated in the crystal,  $P_{XTAL}$ , can be computed by:

$$P_{XTAL} = I_{RMS}^2 * R_{ESR} * (1 + C_0/C_L)^2$$

where

- $I_{RMS}$  is the RMS current through the crystal.
  - $R_{ESR}$  is the max. equivalent series resistance specified for the crystal
  - $C_L$  is the load capacitance specified for the crystal
  - $C_0$  is the min. shunt capacitance specified for the crystal
- (4)

$I_{RMS}$  can be measured using a current probe (e.g. Tektronix CT-6 or equivalent) placed on the leg of the crystal connected to OSCout with the oscillation circuit active.

As shown in [Figure 28](#), an external resistor,  $R_{LIM}$ , can be used to limit the crystal drive level, if necessary. If the power dissipated in the selected crystal is higher than the drive level specified for the crystal with  $R_{LIM}$  shorted, then a larger resistor value is mandatory to avoid overdriving the crystal. However, if the power dissipated in the crystal is less than the drive level with  $R_{LIM}$  shorted, then a zero value for  $R_{LIM}$  can be used. As a starting point, a suggested value for  $R_{LIM}$  is 1.5 k $\Omega$ .

## 10.3 Termination and Use of Clock Drivers

When terminating clock drivers keep in mind these guidelines for optimum phase noise and jitter performance:

- Transmission line theory should be followed for good impedance matching to prevent reflections.
- Clock drivers should be presented with the proper loads.
  - LVDS outputs are current drivers and require a closed current loop.
  - HCSL drivers are switched current outputs and require a DC path to ground via 50  $\Omega$  termination.
  - LVPECL outputs are open emitter and require a DC path to ground.
- Receivers should be presented with a signal biased to their specified DC bias level (common mode voltage) for proper operation. Some receivers have self-biasing inputs that automatically bias to the proper voltage level; in this case, the signal should normally be AC coupled.

It is possible to drive a non-LVPECL or non-LVDS receiver with a LVDS or LVPECL driver as long as the above guidelines are followed. Check the datasheet of the receiver or input being driven to determine the best termination and coupling method to be sure the receiver is biased at the optimum DC voltage (common mode voltage).

### 10.3.1 Termination for DC Coupled Differential Operation

For DC coupled operation of an LVDS driver, terminate with 100  $\Omega$  as close as possible to the LVDS receiver as shown in [Figure 29](#).

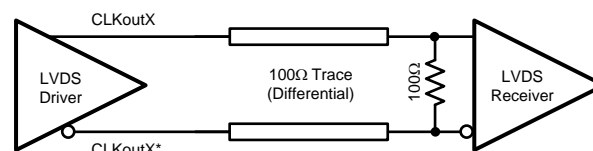

**Figure 29. Differential LVDS Operation, DC Coupling, No Biasing by the Receiver**

### Termination and Use of Clock Drivers (continued)

For DC coupled operation of an HCSL driver, terminate with  $50\ \Omega$  to ground near the driver output as shown in Figure 30. Series resistors,  $R_s$ , may be used to limit overshoot due to the fast transient current. Because HCSL drivers require a DC path to ground, AC coupling is not allowed between the output drivers and the  $50\ \Omega$  termination resistors.

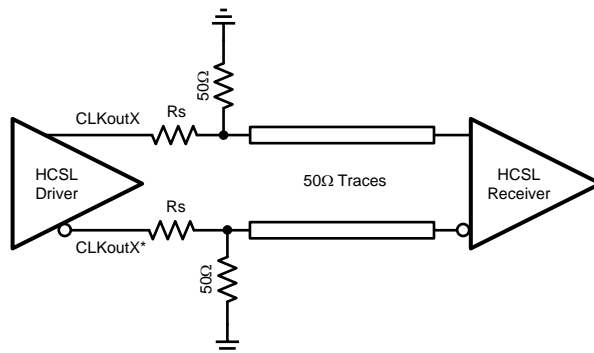

Figure 30. HCSL Operation, DC Coupling

For DC coupled operation of an LVPECL driver, terminate with  $50\ \Omega$  to  $V_{CC0} - 2\text{ V}$  as shown in Figure 31. Alternatively terminate with a Thevenin equivalent circuit as shown in Figure 32 for  $V_{CC0}$  (output driver supply voltage) = 3.3 V and 2.5 V. In the Thevenin equivalent circuit, the resistor dividers set the output termination voltage ( $V_{TT}$ ) to  $V_{CC0} - 2\text{ V}$ .

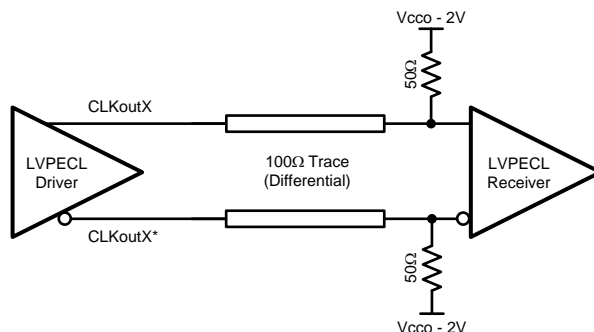

Figure 31. Differential LVPECL Operation, DC Coupling

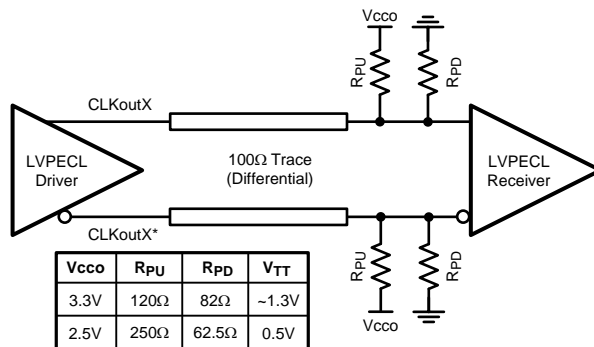

Figure 32. Differential LVPECL Operation, DC Coupling, Thevenin Equivalent

## Termination and Use of Clock Drivers (continued)

### 10.3.2 Termination for AC Coupled Differential Operation

AC coupling allows for shifting the DC bias level (common mode voltage) when driving different receiver standards. Since AC coupling prevents the driver from providing a DC bias voltage at the receiver, it is important to ensure the receiver is biased to its ideal DC level.

When driving differential receivers with an LVDS driver, the signal may be AC coupled by adding DC blocking capacitors; however the proper DC bias point needs to be established at both the driver side and the receiver side. The recommended termination scheme depends on whether the differential receiver has integrated termination resistors or not.

When driving a differential receiver without internal 100 Ω differential termination, the AC coupling capacitors should be placed between the load termination resistor and the receiver to allow a DC path for proper biasing of the LVDS driver. This is shown in Figure 33. The load termination resistor and AC coupling capacitors should be placed as close as possible to the receiver inputs to minimize stub length. The receiver can be biased internally or externally to a reference voltage within the receiver’s common mode input range through resistors in the kilo-ohm range.

When driving a differential receiver with internal 100 Ω differential termination, a source termination resistor should be placed before the AC coupling capacitors for proper DC biasing of the driver as shown in Figure 34. However, with a 100 Ω resistor at the source and the load (i.e. double terminated), the equivalent resistance seen by the LVDS driver is 50 Ω which causes the effective signal swing at the input to be reduced by half. If a self-terminated receiver requires input swing greater than 250 mVpp (differential) as well as AC coupling to its inputs, then the LVDS driver with the double-terminated arrangement in Figure 34 may not meet the minimum input swing requirement; alternatively, the LVPECL or HCSL output driver format with AC coupling is recommended to meet the minimum input swing required by the self-terminated receiver.

When using AC coupling with LVDS outputs, there may be a startup delay observed in the clock output due to capacitor charging. The examples in Figure 33 and Figure 34 use 0.1 μF capacitors, but this value may be adjusted to meet the startup requirements for the particular application.

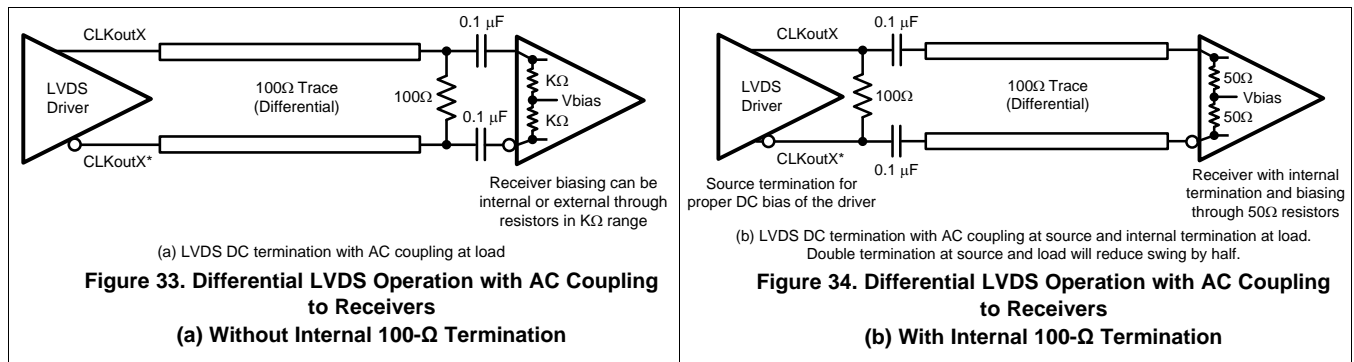

LVPECL drivers require a DC path to ground. When AC coupling an LVPECL signal use 160 Ω emitter resistors (or 91 Ω for V<sub>cc0</sub> = 2.5 V) close to the LVPECL driver to provide a DC path to ground as shown in Figure 38. For proper receiver operation, the signal should be biased to the DC bias level (common mode voltage) specified by the receiver. The typical DC bias voltage (common mode voltage) for LVPECL receivers is 2 V. Alternatively, a Thevenin equivalent circuit forms a valid termination as shown in Figure 35 for V<sub>cc0</sub> = 3.3 V and 2.5 V. Note: this Thevenin circuit is different from the DC coupled example in Figure 32, since the voltage divider is setting the input common mode voltage of the receiver.

Termination and Use of Clock Drivers (continued)

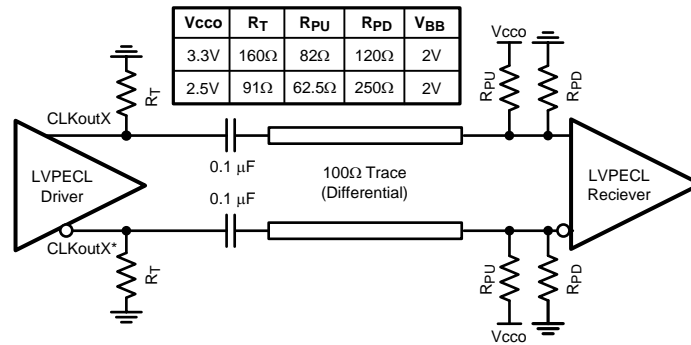

Figure 35. Differential LVPECL Operation, AC Coupling, Thevenin Equivalent

10.3.3 Termination for Single-Ended Operation

A balun can be used with either LVDS or LVPECL drivers to convert the balanced, differential signal into an unbalanced, single-ended signal.

It is possible to use an LVPECL driver as one or two separate 800 mV p-p signals. When DC coupling one of the LMK00308 LVPECL driver of a CLKoutX/CLKoutX\* pair, be sure to properly terminate the unused driver. When DC coupling on of the LMK00308 LVPECL drivers, the termination should be 50 Ω to V<sub>CC0</sub> - 2 V as shown in Figure 36. The Thevenin equivalent circuit is also a valid termination as shown in Figure 37 for V<sub>CC0</sub> = 3.3 V.

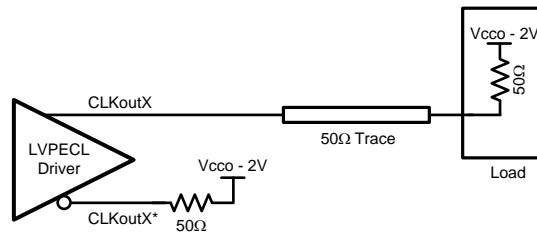

Figure 36. Single-Ended LVPECL Operation, DC Coupling

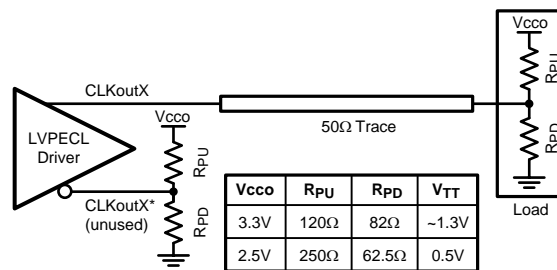
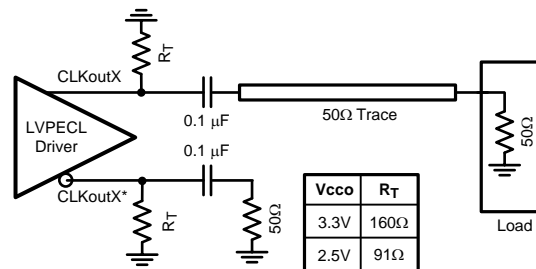

Figure 37. Single-Ended LVPECL Operation, DC Coupling, Thevenin Equivalent

## Termination and Use of Clock Drivers (continued)

When AC coupling an LVPECL driver use a 160  $\Omega$  emitter resistor (or 91  $\Omega$  for  $V_{CC0} = 2.5$  V) to provide a DC path to ground and ensure a 50- $\Omega$  termination with the proper DC bias level for the receiver. The typical DC bias voltage for LVPECL receivers is 2 V. If the companion driver is not used, it should be terminated with either a proper AC or DC termination. This latter example of AC coupling a single-ended LVPECL signal can be used to measure single-ended LVPECL performance using a spectrum analyzer or phase noise analyzer. When using most RF test equipment no DC bias point (0 VDC) is required for safe and proper operation. The internal 50  $\Omega$  termination the test equipment correctly terminates the LVPECL driver being measured as shown in [Figure 38](#). When using only one LVPECL driver of a CLKoutX/CLKoutX\* pair, be sure to properly terminated the unused driver.



**Figure 38. Single-Ended LVPECL Operation, AC Coupling**

## 11 Power Supply Recommendations

### 11.1 Power Supply Sequencing

When powering the V<sub>CC</sub> and V<sub>CCO</sub> pins from separate supply rails, it is recommended for the supplies to reach their regulation point at approximately the same time while ramping up, or reach ground potential at the same time while ramping down. Using simultaneous or ratiometric power supply sequencing prevents internal current flow from V<sub>CC</sub> to V<sub>CCO</sub> pins that could occur when V<sub>CC</sub> is powered before V<sub>CCO</sub>.

### 11.2 Current Consumption and Power Dissipation Calculations

The current consumption values specified in [Electrical Characteristics](#) can be used to calculate the total power dissipation and IC power dissipation for any device configuration. The total V<sub>CC</sub> core supply current (I<sub>CC\_TOTAL</sub>) can be calculated using [Equation 5](#):

$$I_{CC\_TOTAL} = I_{CC\_CORE} + I_{CC\_BANK\_A} + I_{CC\_BANK\_B} + I_{CC\_CMOS}$$

where

- I<sub>CC\_CORE</sub> is the current for core logic and input blocks and depends on selected input (CLKinX or OSCin).
- I<sub>CC\_BANK\_A</sub> is the current for Bank A and depends on output type (I<sub>CC\_PECL</sub>, I<sub>CC\_LVDS</sub>, I<sub>CC\_HCSL</sub>, or 0 mA if disabled).
- I<sub>CC\_BANK\_B</sub> is the current for Bank B and depends on output type (I<sub>CC\_PECL</sub>, I<sub>CC\_LVDS</sub>, I<sub>CC\_HCSL</sub>, or 0 mA if disabled).
- I<sub>CC\_CMOS</sub> is the current for the LVCMOS output (or 0 mA if REFout is disabled). (5)

Since the output supplies (V<sub>CCOA</sub>, V<sub>CCOB</sub>, V<sub>CCOC</sub>) can be powered from 3 independent voltages, the respective output supply currents (I<sub>CCO\_BANK\_A</sub>, I<sub>CCO\_BANK\_B</sub>, and I<sub>CCO\_CMOS</sub>) should be calculated separately.

I<sub>CCO\_BANK</sub> for either Bank A or B can be directly taken from the corresponding output supply current spec (I<sub>CCO\_PECL</sub>, I<sub>CCO\_LVDS</sub>, or I<sub>CCO\_HCSL</sub>) **provided the output loading matches the specified conditions**. Otherwise, I<sub>CCO\_BANK</sub> should be calculated as follows:

$$I_{CCO\_BANK} = I_{BANK\_BIAS} + (N * I_{OUT\_LOAD})$$

where

- I<sub>BANK\_BIAS</sub> is the output bank bias current (fixed value).
- I<sub>OUT\_LOAD</sub> is the DC load current per loaded output pair.
- N is the number of loaded output pairs per bank (N = 0 to 4). (6)

[Table 6](#) shows the typical I<sub>BANK\_BIAS</sub> values and I<sub>OUT\_LOAD</sub> expressions for LVPECL, LVDS, and HCSL.

For LVPECL, it is possible to use a larger termination resistor (R<sub>T</sub>) to ground instead of terminating with 50 Ω to V<sub>TT</sub> = V<sub>CCO</sub> - 2 V; this technique is commonly used to eliminate the extra termination voltage supply (V<sub>TT</sub>) and potentially reduce device power dissipation at the expense of lower output swing. For example, when V<sub>CCO</sub> is 3.3 V, a R<sub>T</sub> value of 160 Ω to ground will eliminate the 1.3 V termination supply without sacrificing much output swing. In this case, the typical I<sub>OUT\_LOAD</sub> is 25 mA, so I<sub>CCO\_PECL</sub> for a fully-loaded bank reduces to 126.5 mA (vs. 132 mA with 50 Ω resistors to V<sub>CCO</sub> - 2 V).

**Table 6. Typical Output Bank Bias and Load Currents**

CURRENT PARAMETER	LVPECL	LVDS	HCSL
I <sub>BANK_BIAS</sub>	26.5 mA	26 mA	4.8 mA
I <sub>OUT_LOAD</sub>	(V <sub>OH</sub> - V <sub>TT</sub> )/R <sub>T</sub> + (V <sub>OL</sub> - V <sub>TT</sub> )/R <sub>T</sub>	0 mA (No DC load current)	V <sub>OH</sub> /R <sub>T</sub>

Once the current consumption is calculated for each supply, the total power dissipation (P<sub>TOTAL</sub>) can be calculated as:

$$P_{TOTAL} = (V_{CC} * I_{CC\_TOTAL}) + (V_{CCOA} * I_{CCO\_BANK\_A}) + (V_{CCOB} * I_{CCO\_BANK\_B}) + (V_{CCOC} * I_{CCO\_CMOS}) \quad (7)$$

If the device configuration is configured with LVPECL and/or HCSL outputs, then it is also necessary to calculate the power dissipated in any termination resistors (P<sub>RT\_PECL</sub> and P<sub>RT\_HCSL</sub>) and in any LVPECL termination voltages (P<sub>VTT\_PECL</sub>). The external power dissipation values can be calculated as follows:

$$P_{RT\_PECL} \text{ (per LVPECL pair)} = (V_{OH} - V_{TT})^2/R_T + (V_{OL} - V_{TT})^2/R_T \quad (8)$$

$$P_{VTT\_PECL} \text{ (per LVPECL pair)} = V_{TT} * [(V_{OH} - V_{TT})/R_T + (V_{OL} - V_{TT})/R_T] \quad (9)$$

**LMK00308**

SNAS576D – FEBRUARY 2012 – REVISED MARCH 2016

[www.ti.com](http://www.ti.com)

$$P_{RT\_HCSL} \text{ (per HCSL pair)} = V_{OH}^2 / R_T$$

(10)

Finally, the IC power dissipation ( $P_{\text{DEVICE}}$ ) can be computed by subtracting the external power dissipation values from  $P_{\text{TOTAL}}$  as follows:

$$P_{\text{DEVICE}} = P_{\text{TOTAL}} - N_1 \cdot (P_{\text{RT\_PECL}} + P_{\text{VTT\_PECL}}) - N_2 \cdot P_{\text{RT\_HCSL}}$$

where

- $N_1$  is the number of LVPECL output pairs with termination resistors to  $V_{\text{TT}}$  (usually  $V_{\text{CCO}} - 2 \text{ V}$  or GND).
- $N_2$  is the number of HCSL output pairs with termination resistors to GND. (11)

### 11.2.1 Power Dissipation Example: Worst-Case Dissipation

This example shows how to calculate IC power dissipation for a configuration to estimate worst-case power dissipation. In this case, the maximum supply voltage and supply current values specified in [Electrical Characteristics](#) are used.

- $V_{\text{CC}} = V_{\text{CCO}} = 3.465 \text{ V}$ . Max  $I_{\text{CC}}$  and  $I_{\text{CCO}}$  values.
- CLKin0/CLKin0\* input is selected.
- Banks A and B are configured for LVPECL: all outputs terminated with  $50 \Omega$  to  $V_{\text{T}} = V_{\text{CCO}} - 2 \text{ V}$ .
- REFout is enabled with  $5 \text{ pF}$  load.
- $T_{\text{A}} = 85 \text{ }^\circ\text{C}$

Using the power calculations from the previous section and *maximum* supply current specifications, we can compute  $P_{\text{TOTAL}}$  and  $P_{\text{DEVICE}}$ .

- From [Equation 5](#):  $I_{\text{CC\_TOTAL}} = 10.5 \text{ mA} + 20 \text{ mA} + 20 \text{ mA} + 5.5 \text{ mA} = 56 \text{ mA}$
- From  $I_{\text{CCO\_PECL}}$  max spec:  $I_{\text{CCO\_BANK\_A}} = I_{\text{CCO\_BANK\_B}} = 160 \text{ mA}$
- From [Equation 7](#):  $P_{\text{TOTAL}} = 3.465 \text{ V} \cdot (56 \text{ mA} + 160 \text{ mA} + 160 \text{ mA} + 10 \text{ mA}) = 1337 \text{ mW}$
- From [Equation 8](#):  $P_{\text{RT\_PECL}} = ((2.57 \text{ V} - 1.47 \text{ V})^2 / 50 \Omega) + ((1.72 \text{ V} - 1.47 \text{ V})^2 / 50 \Omega) = 25.5 \text{ mW}$  (per output pair)
- From [Equation 9](#):  $P_{\text{VTT\_PECL}} = 1.47 \text{ V} \cdot [ ((2.57 \text{ V} - 1.47 \text{ V}) / 50 \Omega) + ((1.72 \text{ V} - 1.47 \text{ V}) / 50 \Omega) ] = 39.5 \text{ mW}$  (per output pair)
- From [Equation 10](#):  $P_{\text{RT\_HCSL}} = 0 \text{ mW}$  (no HCSL outputs)
- From [Equation 11](#):  $P_{\text{DEVICE}} = 1337 \text{ mW} - (8 \cdot (25.5 \text{ mW} + 39.5 \text{ mW})) - 0 \text{ mW} = 817 \text{ mW}$

In this worst-case example, the IC device will dissipate about 817 mW or 61% of the total power (1337 mW), while the remaining 39% will be dissipated in the LVPECL emitter resistors (204 mW for 8 pairs) and termination voltage (316 mW into  $V_{\text{CCO}} - 2 \text{ V}$ ). Based on  $\theta_{\text{JA}}$  of  $31.4 \text{ }^\circ\text{C/W}$ , the estimated die junction temperature would be about  $26 \text{ }^\circ\text{C}$  above ambient, or  $111 \text{ }^\circ\text{C}$  when  $T_{\text{A}} = 85 \text{ }^\circ\text{C}$ .

## 11.3 Power Supply Bypassing

The  $V_{\text{CC}}$  and  $V_{\text{CCO}}$  power supplies should have a high-frequency bypass capacitor, such as  $0.1 \text{ }\mu\text{F}$  or  $0.01 \text{ }\mu\text{F}$ , placed very close to each supply pin.  $1 \text{ }\mu\text{F}$  to  $10 \text{ }\mu\text{F}$  decoupling capacitors should also be placed nearby the device between the supply and ground planes. All bypass and decoupling capacitors should have short connections to the supply and ground plane through a short trace or via to minimize series inductance.

### 11.3.1 Power Supply Ripple Rejection

In practical system applications, power supply noise (ripple) can be generated from switching power supplies, digital ASICs or FPGAs, etc. While power supply bypassing will help filter out some of this noise, it is important to understand the effect of power supply ripple on the device performance. When a single-tone sinusoidal signal is applied to the power supply of a clock distribution device, such as LMK00308, it can produce narrow-band phase modulation as well as amplitude modulation on the clock output (carrier). In the single-side band phase noise spectrum, the ripple-induced phase modulation appears as a phase spur level relative to the carrier (measured in dBc).

### Power Supply Bypassing (continued)

For the LMK00308, power supply ripple rejection, or PSRR, was measured as the single-sideband phase spur level (in dBc) modulated onto the clock output when a ripple signal was injected onto the V<sub>cco</sub> supply. The PSRR test setup is shown in Figure 39.

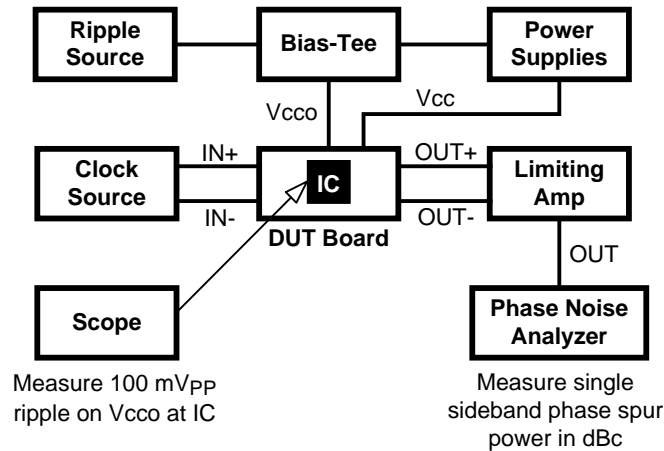

Figure 39. PSRR Test Setup

A signal generator was used to inject a sinusoidal signal onto the V<sub>cco</sub> supply of the DUT board, and the peak-to-peak ripple amplitude was measured at the V<sub>cco</sub> pins of the device. A limiting amplifier was used to remove amplitude modulation on the differential output clock and convert it to a single-ended signal for the phase noise analyzer. The phase spur level measurements were taken for clock frequencies of 156.25 MHz and 312.5 MHz under the following power supply ripple conditions:

- Ripple amplitude: 100 mV<sub>pp</sub> on V<sub>cco</sub> = 2.5 V
- Ripple frequencies: 100 kHz, 1 MHz, and 10 MHz

Assuming no amplitude modulation effects and small index modulation, the peak-to-peak deterministic jitter (DJ) can be calculated using the measured single-sideband phase spur level (PSRR) as follows:

$$DJ \text{ (ps pk-pk)} = [(2 \cdot 10^{(PSRR / 20)}) / (\pi \cdot f_{CLK})] \cdot 10^{12} \tag{12}$$

The “PSRR vs. Ripple Frequency” plots in *Typical Characteristics* show the ripple-induced phase spur levels for the differential output types at 156.25 MHz and 312.5 MHz. The LMK00308 exhibits very good and well-behaved PSRR characteristics across the ripple frequency range for all differential output types. The phase spur levels for LVPECL are below -64 dBc at 156.25 MHz and below -62 dBc at 312.5 MHz. Using Equation 12, these phase spur levels translate to Deterministic Jitter values of 2.57 ps pk-pk at 156.25 MHz and 1.62 ps pk-pk at 312.5 MHz. Testing has shown that the PSRR performance of the device improves for V<sub>cco</sub> = 3.3 V under the same ripple amplitude and frequency conditions.

### 11.4 Thermal Management

Power dissipation in the LMK00308 device can be high enough to require attention to thermal management. For reliability and performance reasons the die temperature should be limited to a maximum of 125 °C. That is, as an estimate, T<sub>A</sub> (ambient temperature) plus device power dissipation times R<sub>θJA</sub> should not exceed 125 °C.

The package of the device has an exposed pad that provides the primary heat removal path as well as excellent electrical grounding to the printed circuit board. To maximize the removal of heat from the package a thermal land pattern including multiple vias to a ground plane must be incorporated on the PCB within the footprint of the package. The exposed pad must be soldered down to ensure adequate heat conduction out of the package.

### Thermal Management (continued)

A recommended land and via pattern is shown in Figure 40. More information on soldering WQFN packages can be obtained at: <http://www.ti.com/packaging>.

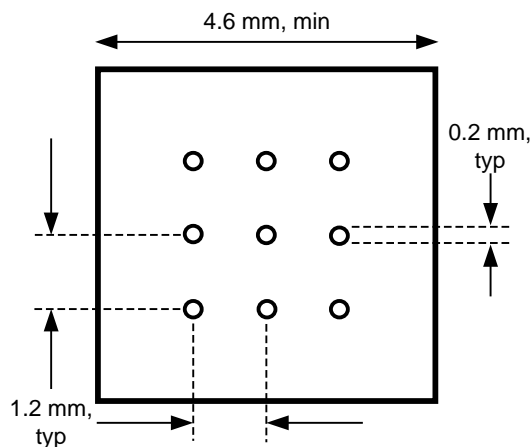

**Figure 40. Recommended Land and Via Pattern**

To minimize junction temperature it is recommended that a simple heat sink be built into the PCB (if the ground plane layer is not exposed). This is done by including a copper area of about 2 square inches on the opposite side of the PCB from the device. This copper area may be plated or solder coated to prevent corrosion but should not have conformal coating (if possible), which could provide thermal insulation. The vias shown in Figure 40 should connect these top and bottom copper layers and to the ground layer. These vias act as “heat pipes” to carry the thermal energy away from the device side of the board to where it can be more effectively dissipated.

## 12 Device and Documentation Support

### 12.1 Documentation Support

#### 12.1.1 Related Documentation

*Common Data Transmission Parameters and their Definitions*, Application Note AN-912 ([SNLA036](#))

### 12.2 Community Resources

The following links connect to TI community resources. Linked contents are provided "AS IS" by the respective contributors. They do not constitute TI specifications and do not necessarily reflect TI's views; see TI's [Terms of Use](#).

**TI E2E™ Online Community** *TI's Engineer-to-Engineer (E2E) Community*. Created to foster collaboration among engineers. At [e2e.ti.com](#), you can ask questions, share knowledge, explore ideas and help solve problems with fellow engineers.

**Design Support** *TI's Design Support* Quickly find helpful E2E forums along with design support tools and contact information for technical support.

### 12.3 Trademarks

E2E is a trademark of Texas Instruments.  
All other trademarks are the property of their respective owners.

### 12.4 Electrostatic Discharge Caution



These devices have limited built-in ESD protection. The leads should be shorted together or the device placed in conductive foam during storage or handling to prevent electrostatic damage to the MOS gates.

### 12.5 Glossary

[SLYZ022](#) — *TI Glossary*.

This glossary lists and explains terms, acronyms, and definitions.

## 13 Mechanical, Packaging, and Orderable Information

The following pages include mechanical, packaging, and orderable information. This information is the most current data available for the designated devices. This data is subject to change without notice and revision of this document. For browser-based versions of this data sheet, refer to the left-hand navigation.

**PACKAGING INFORMATION**

Orderable Device	Status (1)	Package Type	Package Drawing	Pins	Package Qty	Eco Plan (2)	Lead/Ball Finish (6)	MSL Peak Temp (3)	Op Temp (°C)	Device Marking (4/5)	Samples
LMK00308SQ/NOPB	ACTIVE	WQFN	RTA	40	1000	Green (RoHS & no Sb/Br)	CU SN	Level-3-260C-168 HR	-40 to 85	K00308	<a href="#">Samples</a>
LMK00308SQE/NOPB	ACTIVE	WQFN	RTA	40	250	Green (RoHS & no Sb/Br)	CU SN	Level-3-260C-168 HR	-40 to 85	K00308	<a href="#">Samples</a>
LMK00308SQX/NOPB	ACTIVE	WQFN	RTA	40	2500	Green (RoHS & no Sb/Br)	CU SN	Level-3-260C-168 HR	-40 to 85	K00308	<a href="#">Samples</a>

(1) The marketing status values are defined as follows:

**ACTIVE:** Product device recommended for new designs.

**LIFEBUY:** TI has announced that the device will be discontinued, and a lifetime-buy period is in effect.

**NRND:** Not recommended for new designs. Device is in production to support existing customers, but TI does not recommend using this part in a new design.

**PREVIEW:** Device has been announced but is not in production. Samples may or may not be available.

**OBSOLETE:** TI has discontinued the production of the device.

(2) Eco Plan - The planned eco-friendly classification: Pb-Free (RoHS), Pb-Free (RoHS Exempt), or Green (RoHS & no Sb/Br) - please check <http://www.ti.com/productcontent> for the latest availability information and additional product content details.

**TBD:** The Pb-Free/Green conversion plan has not been defined.

**Pb-Free (RoHS):** TI's terms "Lead-Free" or "Pb-Free" mean semiconductor products that are compatible with the current RoHS requirements for all 6 substances, including the requirement that lead not exceed 0.1% by weight in homogeneous materials. Where designed to be soldered at high temperatures, TI Pb-Free products are suitable for use in specified lead-free processes.

**Pb-Free (RoHS Exempt):** This component has a RoHS exemption for either 1) lead-based flip-chip solder bumps used between the die and package, or 2) lead-based die adhesive used between the die and leadframe. The component is otherwise considered Pb-Free (RoHS compatible) as defined above.

**Green (RoHS & no Sb/Br):** TI defines "Green" to mean Pb-Free (RoHS compatible), and free of Bromine (Br) and Antimony (Sb) based flame retardants (Br or Sb do not exceed 0.1% by weight in homogeneous material)

(3) MSL, Peak Temp. - The Moisture Sensitivity Level rating according to the JEDEC industry standard classifications, and peak solder temperature.

(4) There may be additional marking, which relates to the logo, the lot trace code information, or the environmental category on the device.

(5) Multiple Device Markings will be inside parentheses. Only one Device Marking contained in parentheses and separated by a "~" will appear on a device. If a line is indented then it is a continuation of the previous line and the two combined represent the entire Device Marking for that device.

(6) Lead/Ball Finish - Orderable Devices may have multiple material finish options. Finish options are separated by a vertical ruled line. Lead/Ball Finish values may wrap to two lines if the finish value exceeds the maximum column width.

**Important Information and Disclaimer:** The information provided on this page represents TI's knowledge and belief as of the date that it is provided. TI bases its knowledge and belief on information provided by third parties, and makes no representation or warranty as to the accuracy of such information. Efforts are underway to better integrate information from third parties. TI has taken and

continues to take reasonable steps to provide representative and accurate information but may not have conducted destructive testing or chemical analysis on incoming materials and chemicals. TI and TI suppliers consider certain information to be proprietary, and thus CAS numbers and other limited information may not be available for release.

In no event shall TI's liability arising out of such information exceed the total purchase price of the TI part(s) at issue in this document sold by TI to Customer on an annual basis.

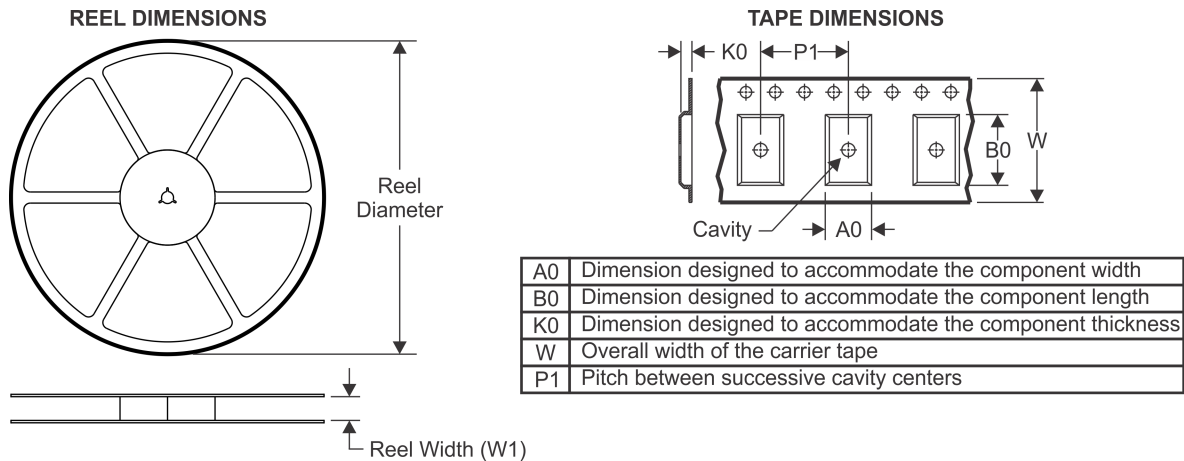
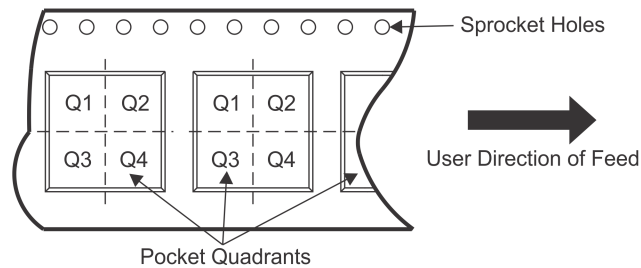
**TAPE AND REEL INFORMATION**

**QUADRANT ASSIGNMENTS FOR PIN 1 ORIENTATION IN TAPE**

\*All dimensions are nominal

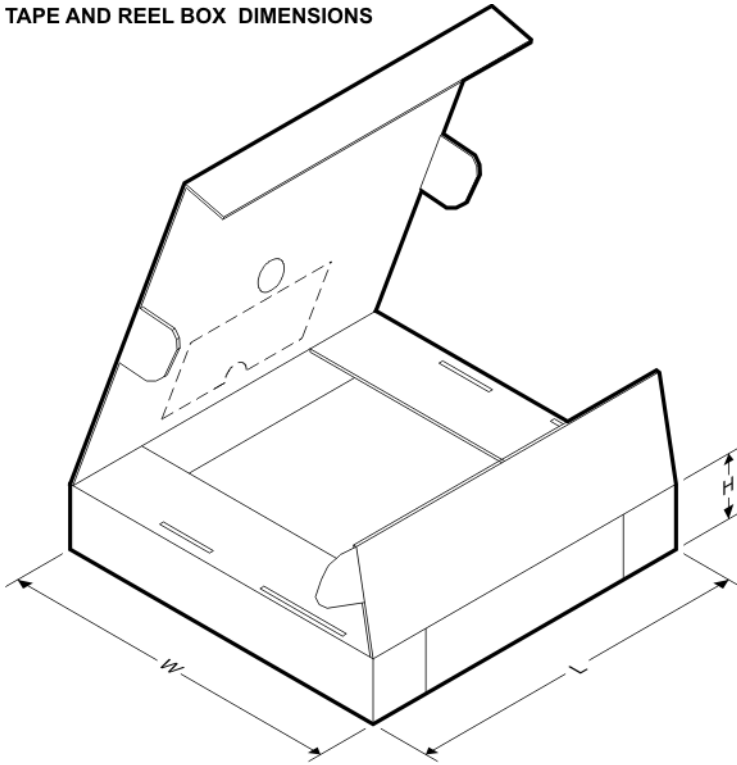
Device	Package Type	Package Drawing	Pins	SPQ	Reel Diameter (mm)	Reel Width W1 (mm)	A0 (mm)	B0 (mm)	K0 (mm)	P1 (mm)	W (mm)	Pin1 Quadrant
LMK00308SQ/NOPB	WQFN	RTA	40	1000	330.0	16.4	6.3	6.3	1.5	12.0	16.0	Q1
LMK00308SQE/NOPB	WQFN	RTA	40	250	178.0	16.4	6.3	6.3	1.5	12.0	16.0	Q1
LMK00308SQX/NOPB	WQFN	RTA	40	2500	330.0	16.4	6.3	6.3	1.5	12.0	16.0	Q1

**TAPE AND REEL BOX DIMENSIONS**

\*All dimensions are nominal

Device	Package Type	Package Drawing	Pins	SPQ	Length (mm)	Width (mm)	Height (mm)
LMK00308SQ/NOPB	WQFN	RTA	40	1000	367.0	367.0	38.0
LMK00308SQE/NOPB	WQFN	RTA	40	250	210.0	185.0	35.0
LMK00308SQX/NOPB	WQFN	RTA	40	2500	367.0	367.0	38.0

RTA0040A

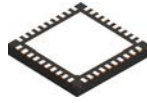

# PACKAGE OUTLINE

WQFN - 0.8 mm max height

PLASTIC QUAD FLATPACK - NO LEAD

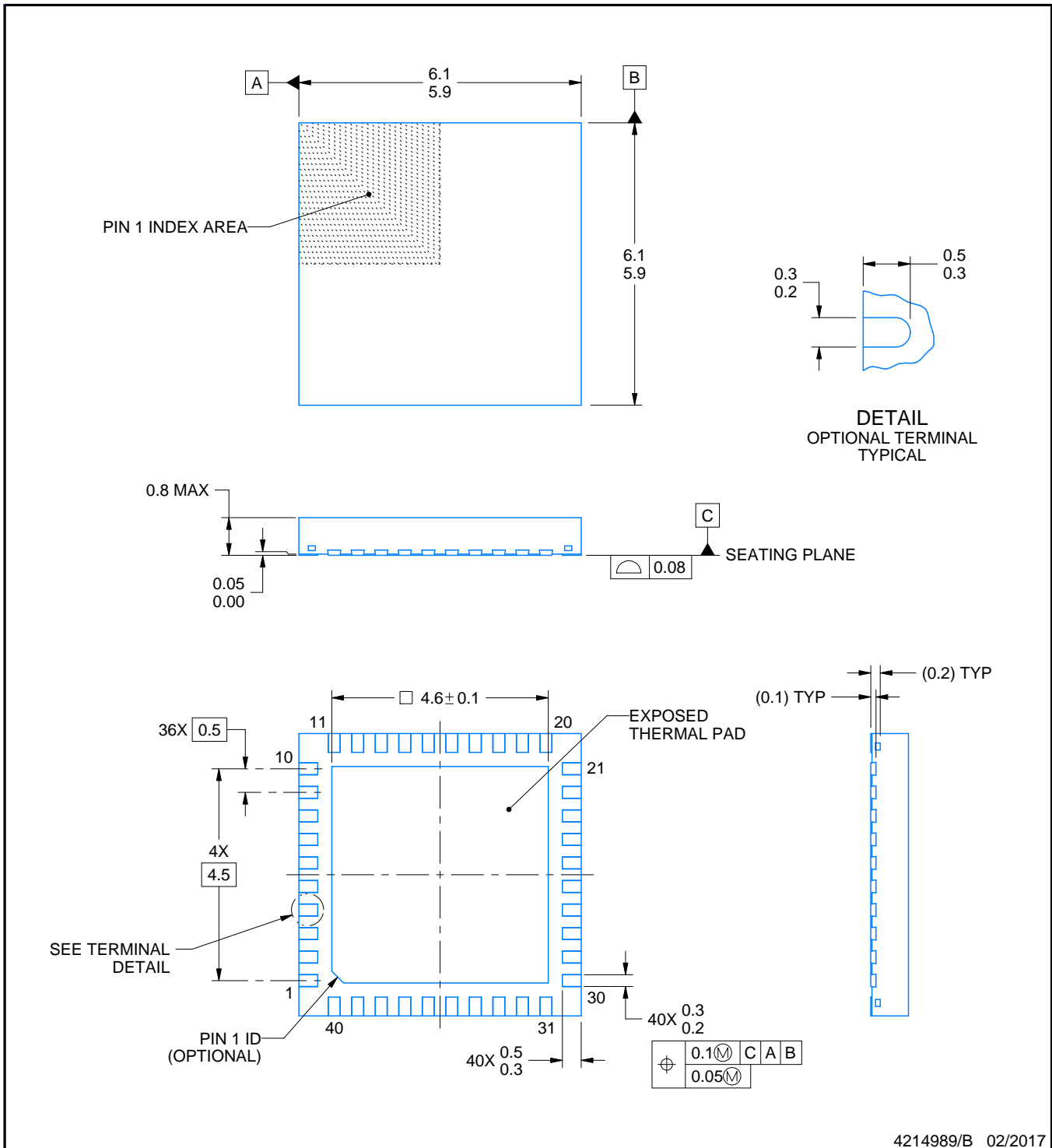

4214989/B 02/2017

NOTES:

- 1. All linear dimensions are in millimeters. Any dimensions in parenthesis are for reference only. Dimensioning and tolerancing per ASME Y14.5M.
- 2. This drawing is subject to change without notice.
- 3. The package thermal pad must be soldered to the printed circuit board for thermal and mechanical performance.

# EXAMPLE BOARD LAYOUT

RTA0040A

WQFN - 0.8 mm max height

PLASTIC QUAD FLATPACK - NO LEAD

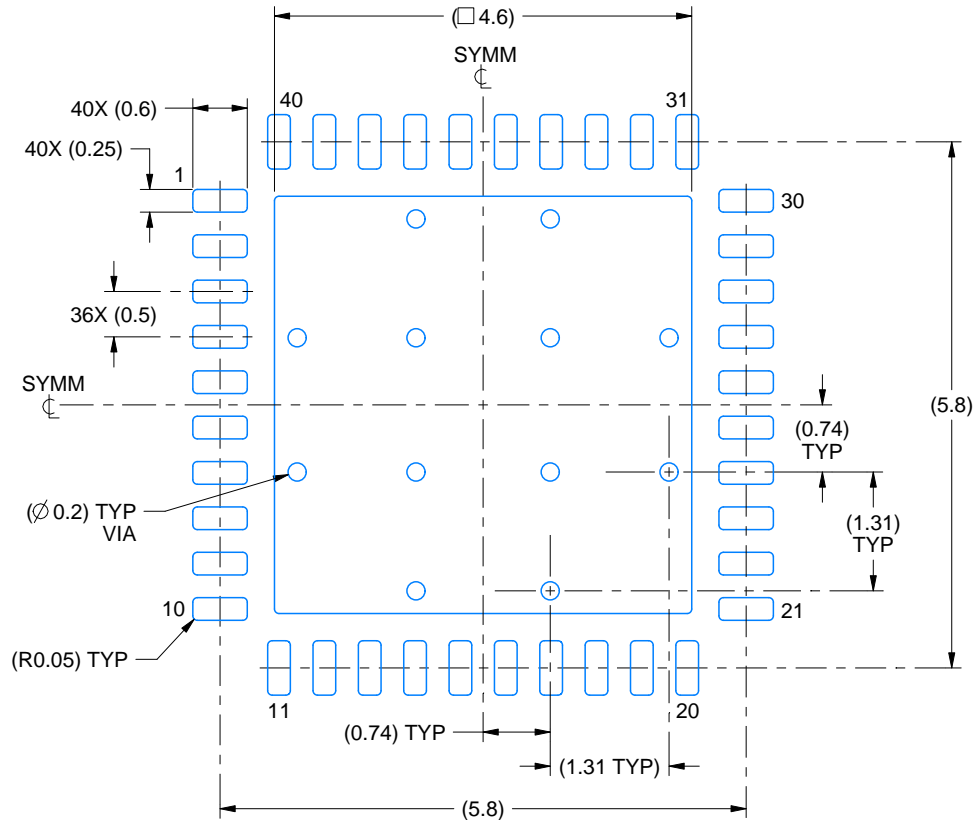

LAND PATTERN EXAMPLE  
EXPOSED METAL SHOWN  
SCALE:12X

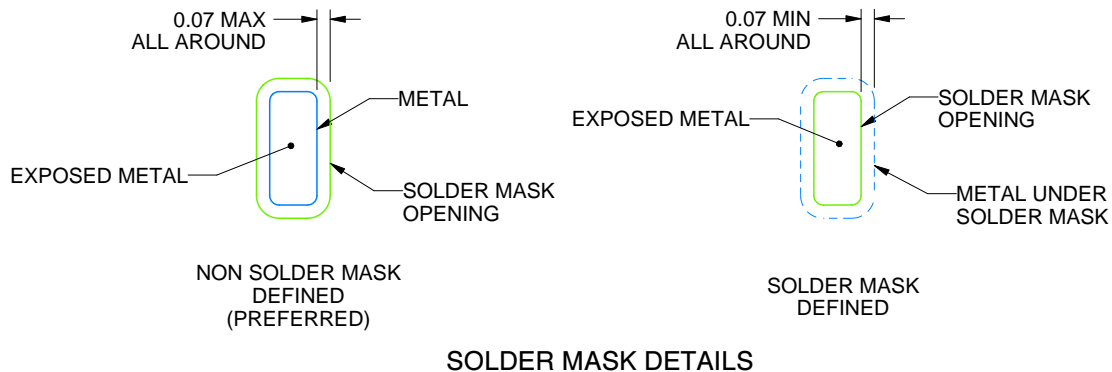

4214989/B 02/2017

NOTES: (continued)

- This package is designed to be soldered to a thermal pad on the board. For more information, see Texas Instruments literature number SLUA271 ([www.ti.com/lit/slua271](http://www.ti.com/lit/slua271)).
- Vias are optional depending on application, refer to device data sheet. If any vias are implemented, refer to their locations shown on this view. It is recommended that vias under paste be filled, plugged or tented.

# EXAMPLE STENCIL DESIGN

RTA0040A

WQFN - 0.8 mm max height

PLASTIC QUAD FLATPACK - NO LEAD

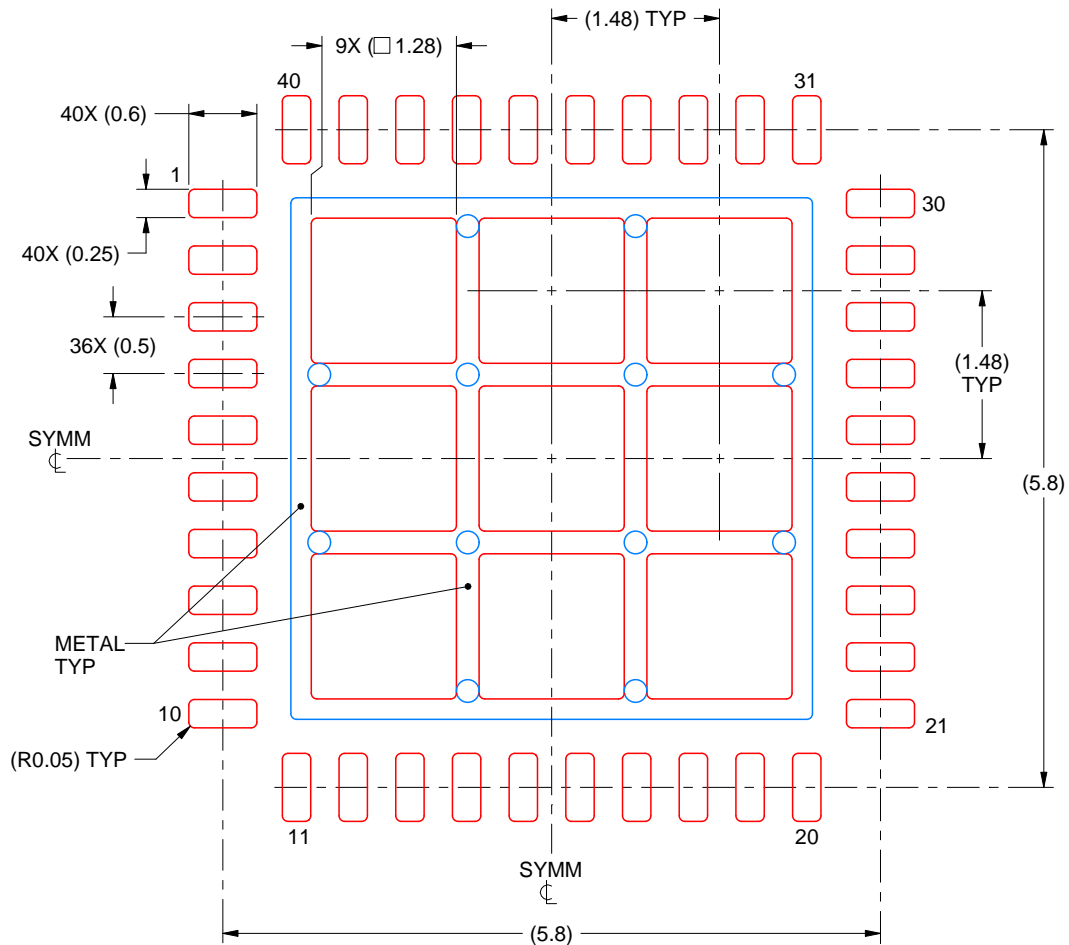

**SOLDER PASTE EXAMPLE**  
BASED ON 0.125 mm THICK STENCIL

EXPOSED PAD  
70% PRINTED SOLDER COVERAGE BY AREA  
SCALE:15X

4214989/B 02/2017

NOTES: (continued)

6. Laser cutting apertures with trapezoidal walls and rounded corners may offer better paste release. IPC-7525 may have alternate design recommendations.

## IMPORTANT NOTICE

Texas Instruments Incorporated (TI) reserves the right to make corrections, enhancements, improvements and other changes to its semiconductor products and services per JESD46, latest issue, and to discontinue any product or service per JESD48, latest issue. Buyers should obtain the latest relevant information before placing orders and should verify that such information is current and complete.

TI's published terms of sale for semiconductor products (<http://www.ti.com/sc/docs/stdterms.htm>) apply to the sale of packaged integrated circuit products that TI has qualified and released to market. Additional terms may apply to the use or sale of other types of TI products and services.

Reproduction of significant portions of TI information in TI data sheets is permissible only if reproduction is without alteration and is accompanied by all associated warranties, conditions, limitations, and notices. TI is not responsible or liable for such reproduced documentation. Information of third parties may be subject to additional restrictions. Resale of TI products or services with statements different from or beyond the parameters stated by TI for that product or service voids all express and any implied warranties for the associated TI product or service and is an unfair and deceptive business practice. TI is not responsible or liable for any such statements.

Buyers and others who are developing systems that incorporate TI products (collectively, "Designers") understand and agree that Designers remain responsible for using their independent analysis, evaluation and judgment in designing their applications and that Designers have full and exclusive responsibility to assure the safety of Designers' applications and compliance of their applications (and of all TI products used in or for Designers' applications) with all applicable regulations, laws and other applicable requirements. Designer represents that, with respect to their applications, Designer has all the necessary expertise to create and implement safeguards that (1) anticipate dangerous consequences of failures, (2) monitor failures and their consequences, and (3) lessen the likelihood of failures that might cause harm and take appropriate actions. Designer agrees that prior to using or distributing any applications that include TI products, Designer will thoroughly test such applications and the functionality of such TI products as used in such applications.

TI's provision of technical, application or other design advice, quality characterization, reliability data or other services or information, including, but not limited to, reference designs and materials relating to evaluation modules, (collectively, "TI Resources") are intended to assist designers who are developing applications that incorporate TI products; by downloading, accessing or using TI Resources in any way, Designer (individually or, if Designer is acting on behalf of a company, Designer's company) agrees to use any particular TI Resource solely for this purpose and subject to the terms of this Notice.

TI's provision of TI Resources does not expand or otherwise alter TI's applicable published warranties or warranty disclaimers for TI products, and no additional obligations or liabilities arise from TI providing such TI Resources. TI reserves the right to make corrections, enhancements, improvements and other changes to its TI Resources. TI has not conducted any testing other than that specifically described in the published documentation for a particular TI Resource.

Designer is authorized to use, copy and modify any individual TI Resource only in connection with the development of applications that include the TI product(s) identified in such TI Resource. NO OTHER LICENSE, EXPRESS OR IMPLIED, BY ESTOPPEL OR OTHERWISE TO ANY OTHER TI INTELLECTUAL PROPERTY RIGHT, AND NO LICENSE TO ANY TECHNOLOGY OR INTELLECTUAL PROPERTY RIGHT OF TI OR ANY THIRD PARTY IS GRANTED HEREIN, including but not limited to any patent right, copyright, mask work right, or other intellectual property right relating to any combination, machine, or process in which TI products or services are used. Information regarding or referencing third-party products or services does not constitute a license to use such products or services, or a warranty or endorsement thereof. Use of TI Resources may require a license from a third party under the patents or other intellectual property of the third party, or a license from TI under the patents or other intellectual property of TI.

TI RESOURCES ARE PROVIDED "AS IS" AND WITH ALL FAULTS. TI DISCLAIMS ALL OTHER WARRANTIES OR REPRESENTATIONS, EXPRESS OR IMPLIED, REGARDING RESOURCES OR USE THEREOF, INCLUDING BUT NOT LIMITED TO ACCURACY OR COMPLETENESS, TITLE, ANY EPIDEMIC FAILURE WARRANTY AND ANY IMPLIED WARRANTIES OF MERCHANTABILITY, FITNESS FOR A PARTICULAR PURPOSE, AND NON-INFRINGEMENT OF ANY THIRD PARTY INTELLECTUAL PROPERTY RIGHTS. TI SHALL NOT BE LIABLE FOR AND SHALL NOT DEFEND OR INDEMNIFY DESIGNER AGAINST ANY CLAIM, INCLUDING BUT NOT LIMITED TO ANY INFRINGEMENT CLAIM THAT RELATES TO OR IS BASED ON ANY COMBINATION OF PRODUCTS EVEN IF DESCRIBED IN TI RESOURCES OR OTHERWISE. IN NO EVENT SHALL TI BE LIABLE FOR ANY ACTUAL, DIRECT, SPECIAL, COLLATERAL, INDIRECT, PUNITIVE, INCIDENTAL, CONSEQUENTIAL OR EXEMPLARY DAMAGES IN CONNECTION WITH OR ARISING OUT OF TI RESOURCES OR USE THEREOF, AND REGARDLESS OF WHETHER TI HAS BEEN ADVISED OF THE POSSIBILITY OF SUCH DAMAGES.

Unless TI has explicitly designated an individual product as meeting the requirements of a particular industry standard (e.g., ISO/TS 16949 and ISO 26262), TI is not responsible for any failure to meet such industry standard requirements.

Where TI specifically promotes products as facilitating functional safety or as compliant with industry functional safety standards, such products are intended to help enable customers to design and create their own applications that meet applicable functional safety standards and requirements. Using products in an application does not by itself establish any safety features in the application. Designers must ensure compliance with safety-related requirements and standards applicable to their applications. Designer may not use any TI products in life-critical medical equipment unless authorized officers of the parties have executed a special contract specifically governing such use. Life-critical medical equipment is medical equipment where failure of such equipment would cause serious bodily injury or death (e.g., life support, pacemakers, defibrillators, heart pumps, neurostimulators, and implantables). Such equipment includes, without limitation, all medical devices identified by the U.S. Food and Drug Administration as Class III devices and equivalent classifications outside the U.S.

TI may expressly designate certain products as completing a particular qualification (e.g., Q100, Military Grade, or Enhanced Product). Designers agree that it has the necessary expertise to select the product with the appropriate qualification designation for their applications and that proper product selection is at Designers' own risk. Designers are solely responsible for compliance with all legal and regulatory requirements in connection with such selection.

Designer will fully indemnify TI and its representatives against any damages, costs, losses, and/or liabilities arising out of Designer's non-compliance with the terms and provisions of this Notice.